

Superseded

by a later version of this document

PacketCable™

Cellular Integration Specification

PKT-SP-CI-I01-070628

ISSUED

Notice

This PacketCable specification is a cooperative effort undertaken at the direction of Cable Television Laboratories, Inc. (CableLabs®) for the benefit of the cable industry. Neither CableLabs, nor any other entity participating in the creation of this document, is responsible for any liability of any nature whatsoever resulting from or arising out of use or reliance upon this document by any party. This document is furnished on an AS-IS basis and neither CableLabs, nor other participating entity, provides any representation or warranty, express or implied, regarding its accuracy, completeness, or fitness for a particular purpose.

© Copyright 2007 Cable Television Laboratories, Inc.
All rights reserved.

Document Status Sheet

Document Control Number:	PKT-SP-CI-I01-070628			
Document Title:	Cellular Integration Specification			
Revision History:	I01 - Released 06/28/07			
Date:	June 28, 2007			
Status:	Work in Progress	Draft	Issued	Closed
Distribution Restrictions:	Author Only	CL/Member	CL/Member/Vendor	Public

Key to Document Status Codes:

- Work in Progress** An incomplete document, designed to guide discussion and generate feedback that may include several alternative requirements for consideration.
- Draft** A document in specification format considered largely complete, but lacking review by Members and vendors. Drafts are susceptible to substantial change during the review process.
- Issued** A stable document, which has undergone rigorous member and vendor review and is suitable for product design and development, cross-vendor interoperability, and for certification testing.
- Closed** A static document, reviewed, tested, validated, and closed to further engineering change requests to the specification through CableLabs.

Trademarks:

CableLabs®, DOCSIS®, EuroDOCSIS™, eDOCSIS™, M-CMTS™, PacketCable™, EuroPacketCable™, PCMM™, CableHome®, CableOffice™, OpenCable™, OCAP™, CableCARD™, M-Card™, and DCAS™ are trademarks of Cable Television Laboratories, Inc.

Contents

1	SCOPE	1
1.1	Introduction and Purpose.....	1
1.2	Requirements.....	1
2	REFERENCES	3
2.1	Normative References.....	3
2.2	Informative References.....	5
2.3	Reference Acquisition.....	6
3	TERMS AND DEFINITIONS	7
4	ABBREVIATIONS AND ACRONYMS	8
5	OVERVIEW	10
5.1	PacketCable Design Goals for Cellular Integration.....	10
5.2	PacketCable Functional Components for Cellular Integration.....	10
5.2.1	<i>Home Location Registers (HLRs) and Authentication Centers</i>	10
5.2.2	<i>Voice Call Continuity Application Server (VCC AS)</i>	10
5.2.3	<i>PacketCable Dual-mode Wireless UE</i>	11
5.2.4	<i>Push-to-Talk over Cellular (PoC) Application Server</i>	11
5.3	Cellular Network Access Models.....	11
5.3.1	<i>Circuit Cellular Network Access</i>	11
5.3.2	<i>Packet Cellular Network Access</i>	11
5.4	Protocol Interfaces for Cellular Integration.....	12
5.4.1	<i>3GPP Circuit Cellular Integration</i>	12
5.4.2	<i>3GPP2 Circuit Cellular Integration</i>	14
5.4.3	<i>3GPP Packet Cellular Interoperability</i>	16
5.4.4	<i>3GPP2 Packet Cellular Interoperability</i>	17
5.4.5	<i>Integration with 3GPP Accounting</i>	18
5.4.6	<i>Integration with 3GPP2 Accounting</i>	20
6	NORMATIVE REFERENCE APPLICATION	22
6.1	Tailoring of PKT-SP-24.229 for Circuit Cellular Integration.....	22
6.1.1	<i>P-Access-Network-Info</i>	22
6.1.2	<i>P-Associated-URI</i>	22
6.2	Network Address Translation Firewall Traversal.....	22
6.3	Security.....	22
6.4	Codecs.....	23
7	CELLULAR INTEGRATION REQUIREMENTS	24
7.1	General Requirements.....	24
7.2	Home Location Register for Circuit and Packet Cellular Roaming.....	24
7.2.1	<i>PacketCable Support for 3GPP HLR and AuC</i>	24
7.2.2	<i>PacketCable Support for TIA HLR and RADIUS Server</i>	25
7.3	Voice Call Continuity for 3GPP Circuit Cellular Networks.....	26
7.3.1	<i>General Requirements</i>	26
7.3.2	<i>Configuration Considerations</i>	26
7.3.3	<i>3GPP-UE Requirements</i>	27
7.3.4	<i>3GPP-VCC AS Requirements</i>	29
7.4	Voice Call Continuity for 3GPP2 Circuit Cellular Networks.....	31
7.4.1	<i>General Requirements</i>	31

7.4.2	VCC Configuration Considerations.....	32
7.4.3	3GPP2-UE Requirements.....	33
7.4.4	3GPP2-VCC AS Requirements.....	35
7.5	Telephony Supplementary Services.....	38
7.5.1	Supplementary Service Execution Models.....	38
7.6	Hybrid Service Execution (HSE) Model.....	38
7.6.1	Caller ID Delivery (CND and CNAMD).....	39
7.6.2	Caller ID Per-Call Delivery.....	40
7.6.3	Caller ID Per-Line Blocking.....	41
7.6.4	Caller ID Per-Call Blocking.....	41
7.6.5	Anonymous Call Rejection (ACR).....	42
7.6.6	Call Forwarding.....	43
7.6.7	Outbound Call Blocking.....	44
7.6.8	Collect Call Blocking.....	45
7.6.9	Solicitor Blocking.....	45
7.6.10	Call Wait.....	46
7.6.11	Call Hold.....	47
7.6.12	Call Transfer.....	48
7.6.13	N-Way Calling.....	49
7.6.14	Do Not Disturb.....	54
7.6.15	Subscriber Programmable PIN (SPP).....	54
7.6.16	Distinctive Alerting.....	55
7.6.17	Message Waiting Indicator.....	55
7.6.18	Speed dialing.....	56
7.6.19	Customer Originated Trace.....	56
7.6.20	Subscriber List Editing.....	58
7.6.21	Call History Features.....	58
7.6.22	Operator services.....	59
7.7	Transfer of Mid-Call Services.....	59
7.7.1	Call Wait.....	59
7.7.2	Call Hold.....	61
7.7.3	Domain Transfer Interaction with N-Way Calling.....	62
7.8	Mobile Device Requirements.....	64
7.9	Emergency Call Requirements.....	65
7.9.1	General Requirements and Scope.....	65
7.9.2	PacketCable UE - Emergency Call Origination.....	65
7.9.3	VCC AS.....	65
7.9.4	P-CSCF.....	65
7.9.5	E-CSCF.....	66
7.9.6	S-CSCF.....	66
7.10	Push-To-Talk over Cellular (PoC) applied to PacketCable.....	66
APPENDIX I HYBRID CONTROL MODEL FLOWS (INFORMATIVE).....		67
I.1	UE Registration in PacketCable Domain.....	67
I.2	UE Registration in CS Domain.....	67
I.2.1	UE Registration in CS Domain - 3GPP2.....	67
I.2.2	UE Registration in CS Domain - 3GPP.....	68
I.3	UE Origination Call Setup in PacketCable Domain.....	69
I.4	UE Origination Call Setup in CS Domain.....	70
I.4.1	Media Path Optimization through MGC/MG Selection.....	72
I.5	UE Termination Call Setup in PacketCable Domain.....	72
I.6	UE Termination Call Setup in CS Domain.....	73
I.6.1	Media Path Optimization through MGC/MG Selection.....	75
I.7	CS to PacketCable VCC Domain Transfer Procedure for 2 Party Call.....	75
I.8	PacketCable to CS VCC Domain Transfer Procedure for 2 Party Call.....	76

APPENDIX II DOMAIN TRANSFER OF CALLS ON HOLD, CALLS IN WAIT AND N-WAY

CALLS FLOWS (INFORMATIVE)	78
II.1 Call Hold Flows.....	78
II.1.1 CS to PacketCable Domain Transfer.....	78
II.1.2 PacketCable to CS Cellular Domain Transfer	80
II.2 Call Waiting Domain Transfer Flows.....	87
II.2.1 CS to PacketCable Domain Transfer.....	87
II.2.2 PacketCable to CS Domain Transfer.....	89
II.3 N-way Call Domain Transfer Flows.....	92
APPENDIX III 3GPP2 VCC REFERENCES	94
APPENDIX IV OUT OF SCOPE ITEMS	95
APPENDIX V ACKNOWLEDGEMENTS	96

Figures

Figure 1 - PacketCable Interfaces to 3GPP Circuit Cellular Networks	13
Figure 2 - PacketCable Interfaces to 3GPP2 Circuit Cellular Networks	15
Figure 3 - PacketCable Interfaces to 3GPP Packet Cellular Networks	17
Figure 4 - PacketCable Interfaces to 3GPP2 Packet Cellular Networks	18
Figure 5 - Scenario 1: PacketCable operator owns a CS/PS network	19
Figure 6 - Scenario 2: PacketCable operator is a CS/PS MVNO hosted by another MNO	19
Figure 7 - Scenario 3: PacketCable operator is a full CS/PS MVNO.....	20
Figure 8 - Creation of an N-way Conference	51
Figure 9 - Inviting an N-way Conference Participant with REFER to N-way AS	52
Figure 10 - Inviting an N-way Conference Participant with REFER to Participant.....	53
Figure 11 - Rejection of an N-way Conference Controller Domain Transfer Request	64
Figure 12 - UE Registration in PacketCable Domain.....	67
Figure 13 - UE Registration in CS Domain (3GPP2).....	68
Figure 14 - UE Registration in CS Domain (3GPP).....	69
Figure 15 - UE Origination Call Setup in PacketCable Domain	70
Figure 16 - UE Origination Call Setup in CS Domain	71
Figure 17 - UE Termination Call Setup in PacketCable Domain.....	73
Figure 18 - UE Termination Call Setup in CS Domain.....	74
Figure 19 - UE Domain Transfer from CS Domain to PacketCable Domain.....	75
Figure 20 - UE Domain Transfer from PacketCable Domain to CS Domain.....	76
Figure 21 - Domain Transfer of a Call on Hold: CS domain to IMS	78
Figure 22 - PC to 3GPP CS - A-B on hold prior to transfer, A-C was UE initiated	80
Figure 23 - PC to 3GPP CS, A-B on hold prior to transfer, A-C was VCC AS initiated.....	81
Figure 24 - PacketCable to 3GPP CS Transfer of Call Hold and 3WC Establishment, A-B active prior to transfer, A-C was UE initiated (1 of 2)	82
Figure 25 - PacketCable to 3GPP CS Transfer of Call Hold and 3WC Establishment, A-B active prior to transfer, A-C was UE initiated (2 of 2)	83
Figure 26 - PacketCable to 3GPP CS Transfer of Call Hold, A-B active prior to transfer, A-C was VCC AS initiated (1 of 2).....	84
Figure 27 - PacketCable to 3GPP CS Transfer of Call Hold, A-B active prior to transfer, A-C was VCC AS initiated (2 of 2).....	85
Figure 28 - PacketCable to 3GPP CS Transfer of Call Hold, A-B active prior to transfer, A-C was UE initiated, C Disconnects While on Hold	86
Figure 29 - Domain Transfer of Call Waiting: CS domain to PacketCable	87
Figure 30 - Domain Transfer for a Call waiting: PC to CS domain	89
Figure 31 - PC to 3GPP2 CS Transfer of call waiting, A-B on Hold prior to Transfer, A-C was VCC AS Initiated.....	91
Figure 32 - PC to 3GPP2 CS Transfer of Call Waiting, A-B Active prior to Transfer, A-C was VCC AS Initiated.....	92
Figure 33 - PacketCable to 3GPP2 CS Transfer of Multi-Party Call, A-B on Hold prior to Transfer, A-C was UE Initiated	93

Tables

Table 1 - PacketCable Interfaces to 3GPP Circuit Cellular Networks	13
Table 2 - PacketCable Interfaces to 3GPP2 Circuit Cellular Networks	16
Table 3 - PacketCable Interfaces to 3GPP Packet Cellular Networks.....	17
Table 4 - PacketCable Interfaces to 3GPP2 Packet Cellular Networks.....	18
Table 5 - Configurable 3GPP-UE VDN and VDI Values	27
Table 6 - Configurable 3GPP2-UE VDN and VDI Values	34
Table 7 - Feature Data for N-way Conferencing.....	50
Table 8 - Customer Originated Trace Feature Data Modified by Wireless Inter-working.....	57
Table 9 - Intelligent Network Messages on CS Call Origination	71
Table 10 - Intelligent Network Messages on CS Call Termination.....	74
Table 11 - Summary of 3GPP2 VCC References.....	94

This page left blank intentionally.

1 SCOPE

1.1 Introduction and Purpose

This document specifies voice call continuity requirements between PacketCable and circuit cellular networks defined by 3GPP and 3GPP2. PacketCable access is limited to residential WiFi access points connected to the customer's cable modem. For the purposes of this specification, a dual-mode handset is specified to operate on both PacketCable and circuit cellular networks.

The circuit cellular integration requirements support the ability of PacketCable dual-mode handsets to (1) roam onto circuit cellular networks with PacketCable subscriptions, (2) establish voice calls on PacketCable or circuit cellular networks and (3) provide continuous voice service for existing calls as the dual-mode handset transitions between PacketCable and circuit cellular networks.

This document also specifies a selected set of telephony services that can be executed on either PacketCable or circuit cellular networks. The telephony service set defined here is based upon PacketCable Residential SIP Telephony, and adapted for use with a dual-mode handset. This document addresses how to provide the user a consistent telephony feature experience on either PacketCable or circuit cellular networks and during domain transfers between networks.

The following topics are currently out of scope for this document:

- Voice call continuity of emergency calls
- Detailed protocol definitions to support client and application server provisioning of feature data identified by this document
- Client digit map aspects which translate user actions into network signaling
- Voice call continuity with non-circuit cellular networks, such as packet cellular networks, public WiFi and public WiMax networks
- Roaming of subscribers between cable networks
- The seamless transfer of N-way conference call control between PacketCable and circuit cellular networks

1.2 Requirements

Throughout this document, the words that are used to define the significance of particular requirements are capitalized. These words are:

"MUST"	This word means that the item is an absolute requirement of this specification.
"MUST NOT"	This phrase means that the item is an absolute prohibition of this specification.
"SHOULD"	This word means that there may exist valid reasons in particular circumstances to ignore this item, but the full implications should be understood and the case carefully weighed before choosing a different course.

- "SHOULD NOT" This phrase means that there may exist valid reasons in particular circumstances when the listed behavior is acceptable or even useful, but the full implications should be understood and the case carefully weighed before implementing any behavior described with this label.
- "MAY" This word means that this item is truly optional. One vendor may choose to include the item because a particular marketplace requires it or because it enhances the product, for example; another vendor may omit the same item.

2 REFERENCES

2.1 Normative References

In order to claim compliance with this specification, it is necessary to conform to the following standards and other works as indicated, in addition to the other requirements of this specification. Notwithstanding, intellectual property rights may be required to use or implement such normative references.

- [C.S0005] 3rd Generation Partnership Project 2: Upper Layer (Layer 3) Signaling Standard for CDMA2000 Spread Spectrum Systems, C.S0005-D v2.0, October 2005.
- [C.S0014] 3rd Generation Partnership Project 2: Enhanced Variable Rate Codec, Speech Service Option 3 for Wideband Spread Spectrum Digital Systems, January 1997.
- [CODEC-MEDIA] PacketCable Codec and Media Specification, PKT-SP-CODEC-MEDIA-I02-061013, October 13, 2006, Cable Television Laboratories, Inc.
- [IEEE 802.11] IEEE: 802.11G-2003 Telecommunications and information exchange between systems - Local and metropolitan area networks - Specific requirements - Part 11: Wireless LAN Medium Access Control (MAC) and Physical Layer (PHY) specifications, Amendment 4: Further Higher Data Rate Extension in the 2.4Ghz band, June 2003.
- [IETF 3842] IETF RFC 3842, A Message Summary and Message Waiting Indication Event Package for the Session Initiation Protocol (SIP), August 2004.
- [N.S0005] 3rd Generation Partnership Project 2: Cellular Radio Telecommunications Intersystem Operations, Telecommunications Industry Association, N.S0005, TIA/EIA-41-D: December 1997.
- [N.S0013] 3rd Generation Partnership Project 2: WIN Phase 1, N.S0013-0 v.1, December 1998.
- [OMA-PoC-CP] Open Mobile Alliance™: OMA-TS-PoC-ControlPlane-V1_0_1-200601128-A, November 2006.
- [OMA-PoC-UP] Open Mobile Alliance™: OMA-TS_PoC-UserPlane-V1_0_1-200601128-A, November 2006.
- [P.R0001] 3rd Generation Partnership Project 2: Wireless IP Architecture Based on IETF Protocols, P.R001 v1.0, August 2000.
- [PKT 23.228] PacketCable IMS Specifications, IP Multimedia Subsystem Stage 2: PKT-SP-23.228-I02-061013, October 13, 2006, Cable Television Laboratories, Inc.
- [PKT 23.008] PacketCable IMS Specifications, Organization of Subscriber Data 3GPP TS 23.008, PKT-SP-23.008-I01-060914, September 14, 2006, Cable Television Laboratories, Inc.
- [PKT 24.229] PacketCable IMS Specifications, SIP and SDP Stage 3 Specification 3GPP TS 24.229, PKT-SP-24.229-I02-061013, October 13, 2006, Cable Television Laboratories, Inc.
- [PKT 33.203] PacketCable Access Security for IP-Based Services Specification 3GPP TS 33.203, PKT-SP-33.203-I02-061013, October 13, 2006, Cable Television Laboratories, Inc.
- [PKT 33.210] PacketCable Network Domain Security Specification 3GPP TS 33.210, PKT-SP-33.210-I02-061013, October 13, 2006, Cable Television Laboratories, Inc.
- [PKT 33.220] PacketCable Generic Authentication Architecture Specification 3GPP TS 33.220, PKT-SP-33.220-I02-061013, October 13, 2006, Cable Television Laboratories, Inc.
- [PKT ACCT] PacketCable Accounting Specification, PKT-SP-ACCT-I02-061013, October 13, 2006, Cable Television Laboratories, Inc.
- [RST PACM] PacketCable Residential SIP Telephony PACM Specification, PKT-SP-RST-PACM-I01-060927, September 27, 2006, Cable Television Laboratories, Inc.

- [RSTF] PacketCable Residential SIP Telephony Feature Specification, PKT-SP-RSTF-I01-060927, September 27, 2006, Cable Television Laboratories, Inc.
- [S.R0006-0] 3rd Generation Partnership Project 2: Wireless Features Description, S.R0006-0, v1.0, December 1999.
- [TIA/IS-835.2] TIA: CDMA2000® Wireless IP Network Standard, TIA/IS-835, August 2001.
- [TS 23.002] 3rd Generation Partnership Project; Technical Specification Group Core Network and Terminals; Network Architecture, TS 23.002 V 7.2.0, June 2007.
- [TS 23.206] 3rd Generation Partnership Project: Voice Call Continuity (VCC) between Circuit Switched (CS) and IP Multimedia Subsystem (IMS); Stage 2, V7.2.0, March 2007.
- [TS 23.228] 3rd Generation Partnership Project: IP Multimedia Subsystem (IMS); Stage 2, V7.8.0, June 2007.
- [TS 24.008] 3rd Generation Partnership Project; Technical Specification Group Core Network and Terminals; Mobile radio interface Layer 3 specification; Core network protocols; Stage 3, TS 24.008 V 7.8.0, June 2007.
- [TS 24.084] 3rd Generation Partnership Project; MultiParty (MPTY) Supplementary Service; Stage 3, TS 24.084 V6.0.0, January 2005.
- [TS 24.147] 3rd Generation Partnership Project; Conferencing using the IP Multimedia (IM) Core Network (CN) subsystem; Stage 3, TS 24.147, V7.5.0, June 2007.
- [TS 24.206] 3rd Generation Partnership Project; Voice call continuity between Circuit Switched (CS) and IP Multimedia Subsystem (IMS); Stage 3, TS 24.206, V7.2.0, June 2007.
- [TS 24.229] 3rd Generation Partnership Project: Internet Protocol (IP) multimedia call control protocol based on Session Initiation Protocol (SIP) and Session Description Protocol (SDP); Stage 3, V7.8.0, June 2007.
- [TS 26.103] 3rd Generation Partnership Project: Speech codec list for GSM and UMTS, TS 26.103, V6.20, March 2006.
- [TS 29.002] 3rd Generation Partnership Project: Mobile Application Part (MAP); Stage 3, TS 29.002, V7.8.0, June 2007.
- [TS 29.078] 3rd Generation Partnership Project: Customized Applications for Mobile network Enhanced Logic (CAMEL) Phase X; CAMEL Application Part (CAP) specification; Stage 3, TS 29.078, V7.3.0, June 2006.
- [TS 29.328] 3rd Generation Partnership Project: IP Multimedia Subsystem (IMS) Sh interface; Signaling flows and message contents, TS 29.328, V7.6.0, June 2007.
- [X.P0029] 3rd Generation Partnership Project 2: Conferencing the IP Multi-media Core Network Subsystem, pre-released version dated October 2005.
- [X.P0042-001] 3rd Generation Partnership Project 2: Voice Call Continuity between IMS and Circuit Switched Systems - Stage 2, X.P0042-001, in process version, Version v0.85, October 2006.
- [X.P0042-002] 3rd Generation Partnership Project 2: Voice Call Continuity between IMS and Circuit Switched Systems - Stage 3, X.P0042-002, Version v0.04, December 2006.
- [X.S0009] 3rd Generation Partnership Project 2: Wireless Intelligent Network Support for Location Based Services, X.S0009, v1.0, January 2004.
- [X.S0013-002] 3rd Generation Partnership Project 2: All-IP Core Network Multimedia Domain - IP Multimedia Subsystem - Stage 2, X.S0013-002-A v1.0, November, 2005.
- [X.S0013-004] 3rd Generation Partnership Project 2: All-IP Core Network Multimedia Domain - IP Multimedia Call Control Protocol Based on SIP and SDP Stage 3, X.S0013-004-A v1.0, November, 2005.

2.2 Informative References

This specification uses the following informative references.

- [ARCH-FRM TR] PacketCable Architecture Framework Technical Report, PKT-TR-ARCH-FRM-V02-061013, October 13, 2003, Cable Television Laboratories, Inc.
- [N.S0026-A] Wireless Radio Telecommunication Intersystem Non-Signaling Data Communication DMH Rev A (Data Message Handler), December 2001.
- [S.R0005] 3rd Generation Partnership Project 2: Network Reference Model for CDMA2000 Spread Spectrum Systems - Revision B, S.R0005 –B v2.0, June, 2007
- [TD.57] GSM Association, "Transferred Account Procedure Data Record Format", Specification Version Number 3, 17 December 2004
- [TS 22.081] 3rd Generation Partnership Project: Line Identification supplementary services; Stage 1, V6.0.0, December 2003.
- [TS 22.084] 3rd Generation Partnership Project: MultiParty (MPTY) supplementary service; Stage 1, V6.0.0, December 2004.
- [TS 22.096] 3rd Generation Partnership Project: Name identification supplementary services; Stage 1, V6.0.0, December 2004.
- [TS 23.018] 3rd Generation Partnership Project: Basic call handling; Technical realization, V7.4.0, December 2006.
- [TS 23.060] 3rd Generation Partnership Project: General Packet Radio Service (GPRS); Service description; Stage 2, V7.4.0, March 2007.
- [TS 23.078] 3rd Generation Partnership Project: Customized Applications for Mobile network Enhanced Logic (CAMEL) Phase X; Stage 2, V7.8.0, June, 2007.
- [TS 23.081] 3rd Generation Partnership Project: Line Identification supplementary services; Stage 2, V6.0.0, September 2004.
- [TS 23.083] 3rd Generation Partnership Project: Call Waiting (CW) and Call Hold (HOLD) Supplementary Service; Stage 2, V6.0.0, January 2005.
- [TS 23.096] 3rd Generation Partnership Project: Name identification supplementary service; Stage 2, V6.1.0, December 2005.
- [TS 23.271] 3rd Generation Partnership Project; Functional stage 2 description of Location Services (LCS), V7.8.0, June 2007.
- [TS 24.081] 3rd Generation Partnership Project: Line Identification Supplementary Service; Stage 3, TS 24.081, V6.0.0, January 2005.
- [TS 24.083] 3rd Generation Partnership Project; Call Waiting (CW) and Call Hold (HOLD) Supplementary Service; Stage 3, TS 24.083 V6.0.0, January 2005.
- [TS 24.096] 3rd Generation Partnership Project; Name Identification Supplementary Service; Stage 3, TS 24.096 V6.0.0, January 2005.
- [TS 26.234] 3rd Generation Partnership Project, Transparent end-to-end Packet-switched Streaming Service (PSS); Protocols and codecs, TS 26.234, V7.3.0, June 2007.
- [TS 26.235] 3rd Generation Partnership Project, Packet switched conversational multimedia applications; Default codecs, TS 26.235, V7.1.0, March, 2006
- [TS 32.240] 3rd Generation Partnership Project: Telecommunication management; Charging management; Charging architecture and principles, V7.2.0. March 2007.
- [TS 32.250] 3rd Generation Partnership Project: Telecommunication management; Charging management; Circuit Switched (CS) domain charging, V7.0.0, March 2007.
- [TS 32.251] 3rd Generation Partnership Project: Telecommunication management; Charging management; Packet Switched (PS) domain charging, V7.4.0, June 2007.

- [X.S0004-511-E] 3rd Generation Partnership Project 2: ANS/SS7 Transport Signaling Protocols, X.S0004-511-E v1.0, April, 2004.
- [X.S0013-000] 3rd Generation Partnership Project 2: All-IP Core Network Multimedia Domain - Overview, X.S0013-000-A v1.0, November, 2005.
- [X.S0013-007] 3rd Generation Partnership Project 2: All-IP Core Network Multimedia Domain - IP Multimedia Subsystem - Charging Architecture, X.S0013-007-A v1.0, November, 2005.
- [X.S0013-008] 3rd Generation Partnership Project 2: All-IP Core Network Multimedia Domain - IP Multimedia Subsystem - Offline Accounting Information Flows and Protocol, X.S0013-008-A v1.0, November, 2005.

2.3 Reference Acquisition

- Cable Television Laboratories, Inc., 858 Coal Creek Circle, Louisville, CO 80027; Phone +1-303-661-9100; Fax +1-303-661-9199; Internet: <http://www.cablelabs.com/>
- Internet Engineering Task Force (IETF), Internet: <http://www.ietf.org>
- GSM association, <http://www.gsmworld.com/index.shtml>
- 3GPP: www.3gpp.org
- 3GPP2: www.3gpp2.org
- OMA: www.openmobilealliance.org/
- IEEE: <http://www.ieee.org/portal/site>
- TIA: www.tiaonline.org

3 TERMS AND DEFINITIONS

This specification uses the following terms:

3GPP UE	A UE designed to operate on PacketCable or 3GPP circuit cellular networks.
3GPP VCC Application Server	A PacketCable IMS application server that provides voice call continuity with 3GPP circuit cellular networks. The 3GPP VCC AS includes the VCC Application Functional Elements A, B, C and D described in [TS 23.206].
3GPP2 UE	A UE designed to operate on PacketCable or 3GPP2 circuit cellular networks.
3GPP2 VCC Application Server	A PacketCable IMS application server that provides voice call continuity with 3GPP2 circuit cellular networks.
CIBER	Cellular Intercarrier Billing Exchange Roamer
N-way call	N-way call is a general term that refers to either CDMA three way calling or GSM six way multiparty calls.
Residential SIP Telephony	A set of telephony services defined by the PacketCable project.
VCC Application Server	A general term that refers to either the 3GPP or 3GPP2 VCC application server.
VCC UE	A general term that refers to either a 3GPP UE or 3GPP2 UE.
Voice Call Continuity	An application that provides the user a continuous voice experience when transitioning between IMS and circuit cellular domains.

4 ABBREVIATIONS AND ACRONYMS

This specification uses the following abbreviations:

ACR	Anonymous Call Rejection
AS	Application Server
AuC	Authentication Center
B2BUA	Back-To-Back User Agent
CAMEL	Customized Applications for Mobile network Enhanced Logic
CDMA	Code Division Multiple Access
CDR	Call Detail Record
CIBER	Cellular Inter-Carrier Billing Exchange Roamer
CLIP	Calling Line Identity Presentation
CLIR	Calling Line Identity Restriction
CNAMD	Calling Name Delivery
CNAP	Calling Name Presentation
CNAR	Calling Name Restriction
CND	Calling Number Delivery
CNIP	Calling Name Identification Presentation
CNIR	Calling Name Identity Restriction
COT	Customer Originated Trace
CS	Circuit Switched
CSCF	Call Session Control Function
CSRN	CS Domain Routing Number
DN	Directory Number
DND	Do Not Disturb
ESN	Electronic Serial Number
GSM	Global System for Mobile Communications
GMSC	Gateway Mobile Switching Center
GTT	Global Title Translation
HLR	Home Location Register
HSE	Hybrid Service Execution
HSS	Home Subscriber Server
I-CSCF	Interrogating CSCF
iFC	initial Filter Criteria
IMRN	IP Multimedia Routing Number
IMS	IP Multimedia Subsystem
IVR	Interactive Voice Response system
MIN	Mobile Identification Number
MMD	Multi-Media Domain
MNO	Mobile Network Operator

MSC	Mobile Switching Center
MSRN	Mobile Station Roaming Number
MVNO	Mobile Virtual Network Operator
MWI	Message Waiting Indicator
OCB	Outbound Call Blocking
PACM	Provisioning, Activation, Configuration and Management
P-CSCF	Proxy CSCF
PIN	Personal Identity Number
PoC	Push to talk over Cellular
PPS	Permanent Presentation Status
PSAP	Public Safety Answering Point
RACF	Remote Activation of Call Forwarding
RADIUS	Remote Authentication Dial In User Service
RSTF	Residential SIP Telephony Features
RUAC	Rejection of Undesired Anonymous Calls
SCB	Solicitor Call Blocking
SCCP	Signaling Connection Control Part in SS7
SCF	Selective Call Forwarding
gsmSCF	GSM Service Control Function
S-CSCF	Serving CSCF
SIP	Session Initiation Protocol
SMS	Short Message Service
SPP	Subscriber Programmable PIN
SPT	Service Point Trigger
SRI	Send Routing Information
TLDN	Temporary Location Directory Number
UE	User Equipment
UMTS	Universal Mobile Telecommunications System
VCC	Voice Call Continuity
VDI	VCC Domain Transfer URI
VDN	VCC Domain Transfer Number
VLR	Visited Location Register
VMSC	Visited MSC
VSC	Vertical Service Code
WIN	Wireless Intelligent Network

5 OVERVIEW

This section provides an overview of the PacketCable architecture for integration with circuit cellular networks. The architecture is designed to meet the circuit cellular integration functional requirements.

5.1 PacketCable Design Goals for Cellular Integration

The PacketCable architecture is designed to allow the mobile user to experience a consistent set of services regardless of Cable Operator WiFi residential cable access or circuit cellular access. User intervention is not required for the user to roam or move seamlessly between these access networks. The PacketCable Cellular Integration architecture design goals are summarized below:

- Support integration with circuit cellular networks so that PacketCable dual-mode wireless UEs are able to access telephony services consistently whether the access is via the PacketCable network or the circuit cellular network.
- Support interoperability with the 3GPP and 3GPP2 packet-switched domains so that PacketCable dual-mode wireless UEs are able to roam or access packet cellular networks.
- Enable the Cable Operator the choice to maximize telephony service execution in the PacketCable network regardless of wireless or circuit cellular access.
- Define a clear demarcation between networks for authentication, security and feature execution.
- Allow a PacketCable subscriber to be reached with a single number regardless of access network.
- Leverage 3GPP and 3GPP2 standard interfaces and Voice Call Continuity (VCC) specifications.

5.2 PacketCable Functional Components for Cellular Integration

This section describes components added to the PacketCable architecture for circuit cellular integration.

5.2.1 Home Location Registers (HLRs) and Authentication Centers

The Home Location Register (HLR) contains the circuit cellular and packet cellular subscription data and user credentials required for a PacketCable subscriber to roam onto or access cellular circuit and packet networks. The 3GPP HLR supports access to 3GPP (GSM or UMTS) circuit- and packet-switched networks, whereas the TIA HLR supports access to TIA (CDMA) circuit switched networks.

The 3GPP HSS standard reference element can contain both IMS and legacy circuit cellular and packet cellular subscriptions. This document refers to the 3GPP HLR to specifically identify the circuit- and packet-switched portions of the 3GPP defined HSS.

Authentication centers are used in the authentication and access control of users attempting to gain network access. The PacketCable architecture supports either the 3GPP authentication center or the TIA authentication center as well as the 3GPP2 RADIUS server for circuit and packet cellular access.

5.2.2 Voice Call Continuity Application Server (VCC AS)

The VCC AS provides continuous voice calls as a PacketCable UE moves between circuit cellular and PacketCable access networks. The VCC AS contains a back-to-back user agent that establishes a signaling anchor in the

PacketCable network. It is a signaling anchor for call legs from the UE whether on a circuit-switched cellular network or a PacketCable access network to provide continuous voice as the handset moves between PacketCable and cellular networks. By anchoring calls in the PacketCable network, certain PacketCable features can be available when the UE is operating in the circuit-switched cellular network. The VCC AS allows operators to apply policies for access network selection and handover authorization.

The 3GPP VCC AS supports interfaces to 3GPP circuit network (GSM and UMTS). It includes the VCC Application Domain Transfer, CS Adaptation, CAMEL Service Application and Domain Selection functions defined in [TS 23.206]. The 3GPP VCC AS includes the service logic applied to the inter-network CAMEL interface. As such, it provides the function of the GSM Service Control Function (gsmSCF). Alternatively, the 3GPP VCC AS includes an interface to a GSM Service Control Function (gsmSCF) to allow it to provide CAMEL service logic functions.

The 3GPP2 VCC AS supports interfaces to the 3GPP2 circuit network. The 3GPP2 VCC AS provides the 3GPP2 service logic applied to the inter-network WIN interface. As such, it provides the function of the 3GPP2 WIN SCP.

5.2.3 PacketCable Dual-mode Wireless UE

The PacketCable dual-mode wireless UE combines PacketCable VoIP over WiFi with a standard cellular phone. The UE supports a current set of PacketCable and cellular phone features, including a VCC client compatible with the VCC AS described above. As such, the 3GPP UE includes at least a WiFi air interface, a 3GPP circuit cellular air interface and the PacketCable VCC client. The 3GPP UE can also include packet cellular capabilities. The 3GPP2 UE includes at least a WiFi air interface, a 3GPP2 circuit cellular air interface and the PacketCable VCC client. The 3GPP2 UE can also include packet cellular capabilities.

Mobile devices while in the home are likely to operate on a home LAN that includes a NAT and firewall interface to cable network access.

5.2.4 Push-to-Talk over Cellular (PoC) Application Server

The PoC application server provides a half duplex voice application for two way or group calls based upon OMA PoC standards.

5.3 Cellular Network Access Models

5.3.1 Circuit Cellular Network Access

The PacketCable architecture enables the wireless UE to access or roam onto a 3GPP or a 3GPP2 circuit cellular networks using a PacketCable subscription. There are no requirements placed on the UE or network to support access to both 3GPP and 3GPP2 networks simultaneously.

The ability for a circuit cellular subscriber to roam onto the PacketCable network is out of scope for this specification.

5.3.2 Packet Cellular Network Access

The PacketCable architecture enables the wireless UE to roam onto or access either a 3GPP or a 3GPP2 packet cellular networks using a PacketCable subscription. There are no requirements placed on the UE or network to support access to both 3GPP and 3GPP2 networks simultaneously.

This specification does not place any requirements or assumptions on how IP traffic is routed when access is via packet cellular networks. The packet cellular access model supports the ability for user traffic connection points to fixed networks to reside in either the home or visited packet cellular network while the user is roamed out on a visited packet cellular network.

The ability for a packet cellular subscriber to roam onto the PacketCable network is out of scope for this specification.

5.4 Protocol Interfaces for Cellular Integration

5.4.1 3GPP Circuit Cellular Integration

Figure 1 illustrates the network elements and interfaces added to the PacketCable network to support interoperation with 3GPP circuit cellular networks.

A Home Location Register (HLR) is added to support PacketCable subscribers access or roaming onto GSM or UMTS circuit cellular networks. This specification assumes that a Cable Operator HLR is the primary deployment model, although cellular network HLR alternatives are possible. The Cable Operator HLR enables a PacketCable subscriber to be reached with a single telephone number while on cable access or visited circuit switched networks. The PacketCable HLR interfaces to the circuit cellular network MSCs over the standard C and D interfaces.

The 3GPP-VCC AS provides a signaling anchor in the PacketCable network to enable domain transfer between circuit cellular (called CS domain in later sections) and PacketCable domains. When the 3GPP-UE originates a call in the cellular domain, the MSC interfaces to the 3GPP-VCC AS via CAMEL triggers to route the call via the PacketCable network. For calls terminating at the 3GPP-UE, calls are routed to the PacketCable network and the 3GPP-VCC AS anchors the call and determines the correct domain (CS or PacketCable) to use to reach the user. When the 3GPP-UE moves in and out of CS or PacketCable domain coverage, the 3GPP-UE initiates domain transfer calls in the new domain to the 3GPP-VCC AS and the 3GPP-VCC AS acting as an anchor moves the existing connection from the old domain to the new domain.

The Media Gateway Controller (MGC) and Media Gateway (MG) provide PacketCable to circuit translation as a basic PacketCable service and are shown for completeness. Cellular and wireless integration do not place additional requirements on the MGC or MG.

The 3GPP-UE contains both a WiFi radio and 3GPP circuit cellular air interface. Simultaneous operation of both radios is required when doing domain transfers. Once the 3GPP-UE has completed the domain transfer it only requires single radio operation; however, it is expected that most 3GPP-UEs will always leave the 3GPP circuit cellular radio on in idle mode, even when the WiFi radio is in use.

Table 1 summarizes the interfaces used for 3GPP circuit cellular integration.

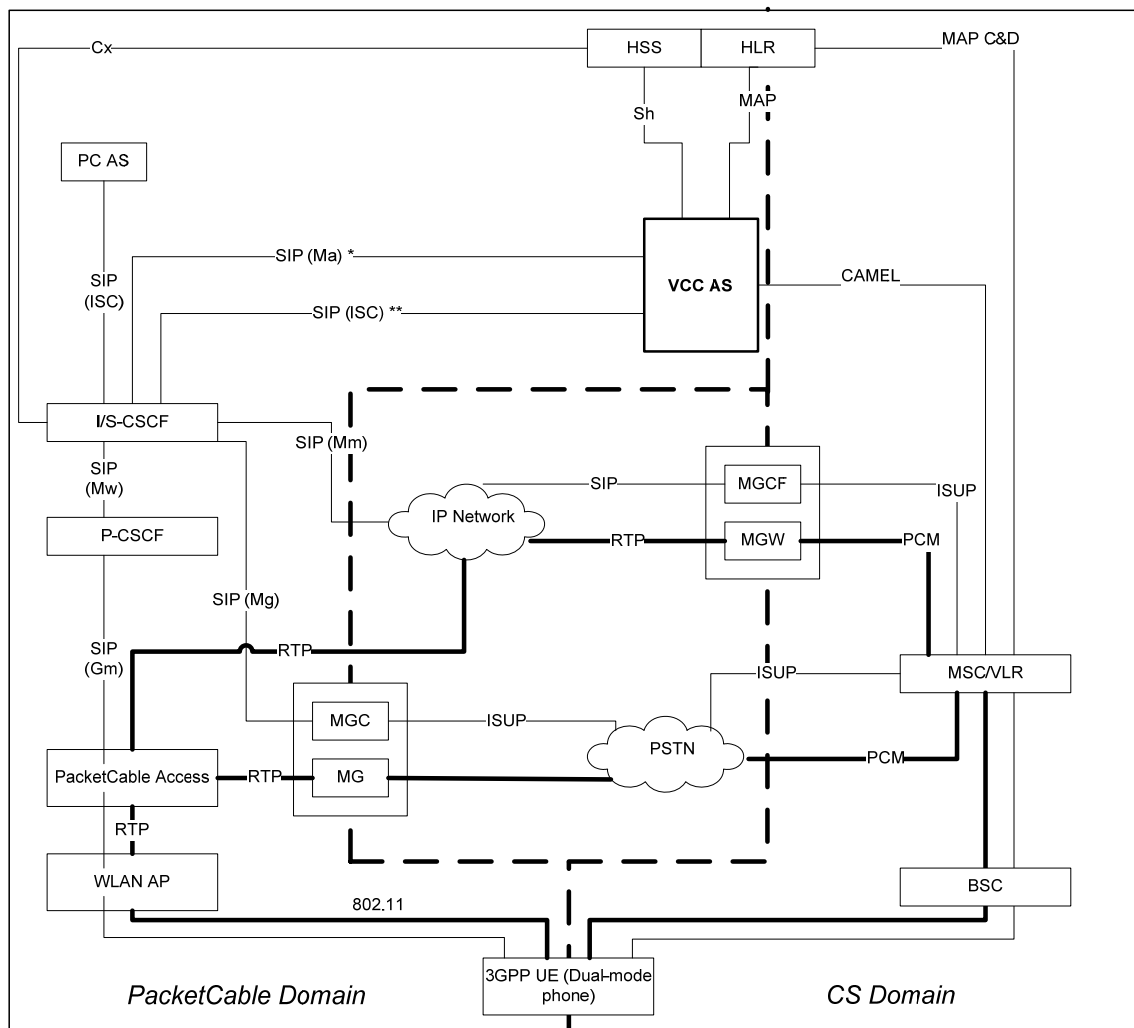

* Ma reference point is used between I-CSCF and AS
 ** ISC Interface is used between S-CSCF and AS

Figure 1 - PacketCable Interfaces to 3GPP Circuit Cellular Networks

Table 1 - PacketCable Interfaces to 3GPP Circuit Cellular Networks

Interface	PacketCable Functional Components	Description
3GPP CAMEL interface for call routing	3GPP-VCC AS and gsmSCF or VMSC	CAMEL call origination triggers are reported from the visited network MSC to the 3GPP-VCC AS. The 3GPP-VCC AS provides an IMRN to route the calls through the PacketCable network.
3GPP MAP C & D	HLR and MSC/VLR	Supports standard GSM intersystem operations, including circuit cellular registration, profile transfer (including CAMEL triggers), user authentication, and network roaming.
3GPP circuit air interface	Dual-mode wireless UE	Access and service per 3GPP GSM or WCDMA circuit air interface specs.

Interface	PacketCable Functional Components	Description
ISC	S-CSCF and 3GPP-VCC AS	This SIP-based interface can be used by the Application Server to control an IP Multimedia session via a S-CSCF. Transactions between the S-CSCF and the 3GPP-VCC Application Server on this interface can be initiated when the S-CSCF proxies a SIP request to the 3GPP-VCC Application Server (upon detecting that an initial Filter Criteria condition is satisfied) or can be initiated by the 3GPP-VCC Application Server when it generates and sends a SIP request to the S-CSCF.
SIP (Ma)	I-CSCF and 3GPP-VCC AS	When a Public Service Identity (PSI) is used to direct a SIP session to an Application Server, an I-CSCF directs the SIP method to the corresponding Application Server, the 3GPP-VCC AS in this case, allowing the 3GPP-VCC AS to influence and impact the SIP session.
Sh	HSS and 3GPP-VCC AS	The Sh interface is between the HSS and the Application Server and can be used for transferring User Profile information.
MAP	HSS and 3GPP-VCC AS	The MAP interface between the 3GPP-VCC AS is used by the VCC AS to route calls to the subscriber in the CS domain. This interface is optional in 3GPP, but recommended for use in PacketCable.

5.4.2 3GPP2 Circuit Cellular Integration

Figure 2 below illustrates the interfaces between the PacketCable and 3GPP2 networks. The architecture is analogous to the integration of 3GPP circuit networks.

A Home Location Register (HLR) is added to support PacketCable subscribers access or roaming onto 3GPP2 (CDMA) circuit cellular networks. The HLR contains the user service profile and credentials required to allow access to visited circuit cellular networks. An Authentication Center (AuC) is also included to assist in user authentication during circuit cellular registration and service requests. The cellular HLR enables a PacketCable subscriber to be reached with a single telephone number while on cable access or visited circuit-switched cellular networks.

When a subscriber successfully registers in the CS domain, the VMSC retrieves the subscription profile for the authenticated subscriber from the HLR and saves it in a local cache. The profile instructs the VMSC which features are available to the subscriber while on the visited circuit cellular network.

The 3GPP2-VCC AS provides a signaling anchor in the PacketCable network to enable domain transfer between circuit cellular (called CS domain in later sections) and PacketCable domains. When the 3GPP2-UE originates a call in the cellular domain, the MSC interfaces to the 3GPP2-VCC AS via WIN triggers to route the call via the PacketCable network. For calls terminating at the 3GPP2-UE, calls are routed to the PacketCable network and the 3GPP2-VCC AS anchors the call and determines the correct domain (CS or PacketCable) to use to reach the user. When the 3GPP2-UE moves in and out of CS or PacketCable domain coverage, the 3GPP2-UE initiates domain transfer calls in the new domain to the 3GPP2-VCC AS and the 3GPP2-VCC AS acting as an anchor moves the existing connection from the old domain to the new domain.

The MGC and MG provide PacketCable to circuit translation as a basic PacketCable service and are shown for completeness. Cellular and wireless integration do not place additional requirements on the MGC or MG.

The 3GPP2-UE contains both a WiFi radio and 3GPP2 circuit cellular air interface. Simultaneous operation of both radios is required when doing domain transfers. Once the 3GPP2-UE has completed the domain transfer, it only requires single radio operation; however, it is expected that most 3GPP2-UEs will always leave the 3GPP2 circuit cellular radio on in idle mode, even when the WiFi radio is in use.

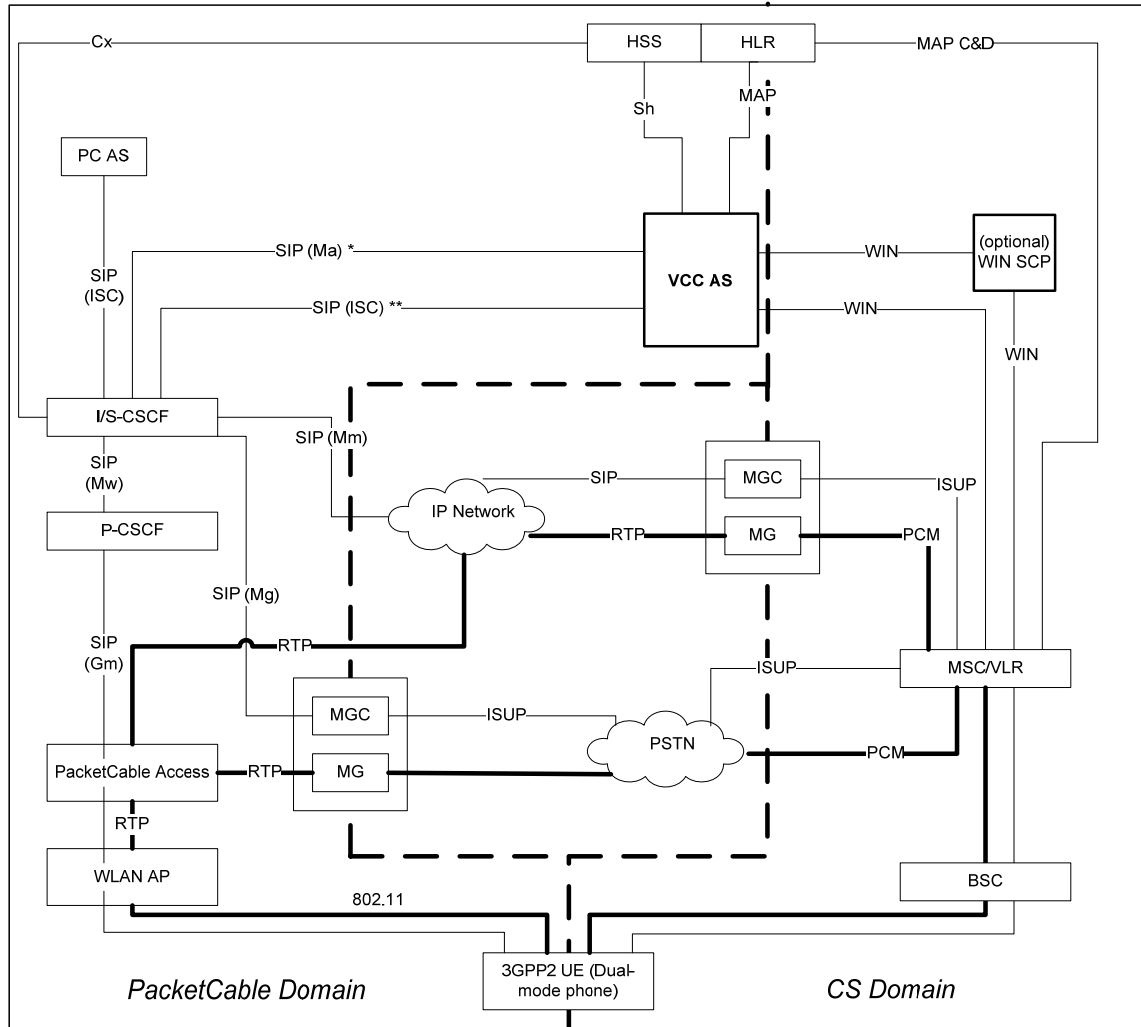

* Ma reference point is used between I-CSCF and AS
 ** ISC Interface is used between S-CSCF and AS

Figure 2 - PacketCable Interfaces to 3GPP2 Circuit Cellular Networks

Table 2 - PacketCable Interfaces to 3GPP2 Circuit Cellular Networks

Interface	PacketCable Functional Components	Description
ANSI-41 MAP	3GPP2 AS and HLR	3GPP2 VCC AS behaves as a pseudo-MSC/VLR for particular VCC functions (e.g., registrations and call delivery), in order to support interworking between the PacketCable and circuit cellular domains.
ANSI-41 (WIN) interface for call routing	3GPP2 AS and MSC	WIN call origination triggers are reported from the visited network MSC to the 3GPP2 VCC AS. The 3GPP2 VCC AS provides an IMRN to route call through the PacketCable network.
ANSI-41 MAP	HLR and MSC/VLR	Supports standard ANSI-41 intersystem operations, including circuit cellular registration, profile transfer (including WIN triggers), user authentication, and network roaming.
1x - CDMA air interface	Dual-mode wireless UE and circuit cellular network	Access and service per 3GPP2 CDMA circuit air interface specs.
ISC	S-CSCF and 3GPP2 VCC AS	This SIP-based interface can be used by the 3GPP2 VCC Application Server to control an IP Multimedia session via a S-CSCF. Transactions between the S-CSCF and the Application Server on this interface can be initiated when the S-CSCF proxies a SIP request to the Application Server (upon detecting that an initial Filter Criteria condition is satisfied) or can be initiated by the Application Server when it generates and sends a SIP request to the S-CSCF.
SIP (Ma)	I-CSCF and 3GPP2 VCC AS	When a Public Service Identity (PSI) is used to direct a SIP session to an Application Server, an I-CSCF directs the SIP method to the corresponding Application Server, allowing the 3GPP2 VCC AS to influence and impact the SIP session
Sh	HSS and 3GPP2 VCC AS	The Sh interface is between the HSS and the Application Server and can be used for transferring User Profile information.

5.4.3 3GPP Packet Cellular Interoperability

Figure 3 illustrates the network elements and interfaces added to the PacketCable network to support interoperation with 3GPP packet cellular networks.

A 3GPP HLR is added to support PacketCable subscribers roaming onto 3GPP packet cellular networks. The HLR contains the user service profile and user credentials required to allow PacketCable access to visited 3GPP packet cellular networks. A 3GPP Authentication center is also included to assist in user authentication during packet cellular registration (GPRS Attach) and service requests. The PacketCable HLR interfaces to the GPRS GGSN and SGSN over the 3GPP standard Gc and Gr interfaces respectively. The 3GPP-UE can access PacketCable services via the internet when it is operating in the packet cellular domain. Internet access for the 3GPP-UE while in the cellular domain is provided by the cellular network and is independent of the internet access while in the PacketCable domain. The specification of a QoS interface between the PacketCable domain and the packet cellular network is outside the scope of this specification and it is expected that only best effort service will be available. This can limit the services available to the 3GPP-UE when operating in the packet cellular domain.

Table 3 summarizes the interfaces used for 3GPP packet cellular integration.

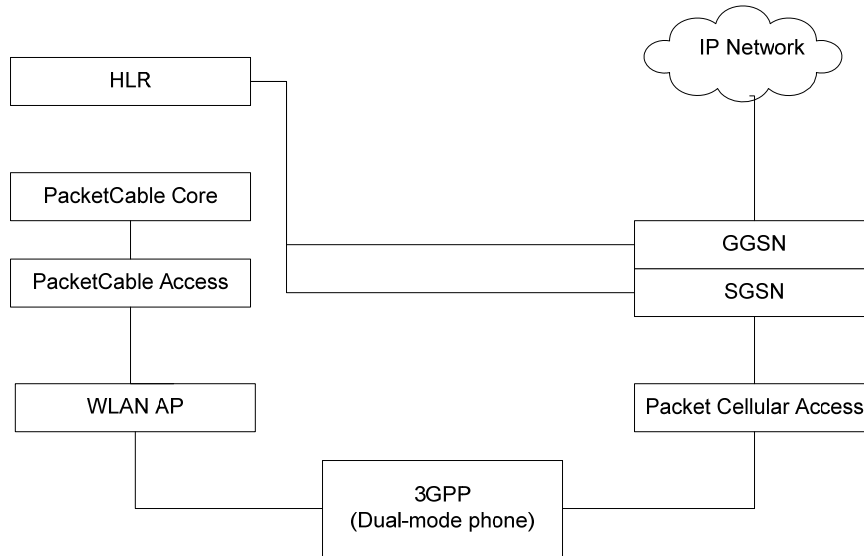

Figure 3 - PacketCable Interfaces to 3GPP Packet Cellular Networks

Table 3 - PacketCable Interfaces to 3GPP Packet Cellular Networks

Interface	PacketCable Functional Components	Description
3GPP Gc and Gr interfaces	3GPP HLR to 3GPP GGSN and SGSN	Transfers subscription data and supports user authentication to support packet cellular network roaming over this MAP based interface
3GPP packet air interface	Dual-mode wireless UE and packet cellular network	Access and service per 3GPP packet cellular air interface specs.

5.4.4 3GPP2 Packet Cellular Interoperability

Figure 4 illustrates the interfaces between the PacketCable and 3GPP2 packet cellular network. A RADIUS server in the PacketCable network interfaces to the PDSN in the visited network. The RADIUS server holds the packet cellular subscription and authenticates the PacketCable subscriber for the packet cellular network.

Internet access for the 3GPP2-UE while in the cellular domain is provided by the cellular network and is independent of the internet access while in the PacketCable domain. The specification of a QoS interface between the PacketCable domain and the packet cellular network is outside the scope of this specification and it is expected that only best effort service will be available. This can limit the services available to the 3GPP2-UE when operating in the packet cellular domain.

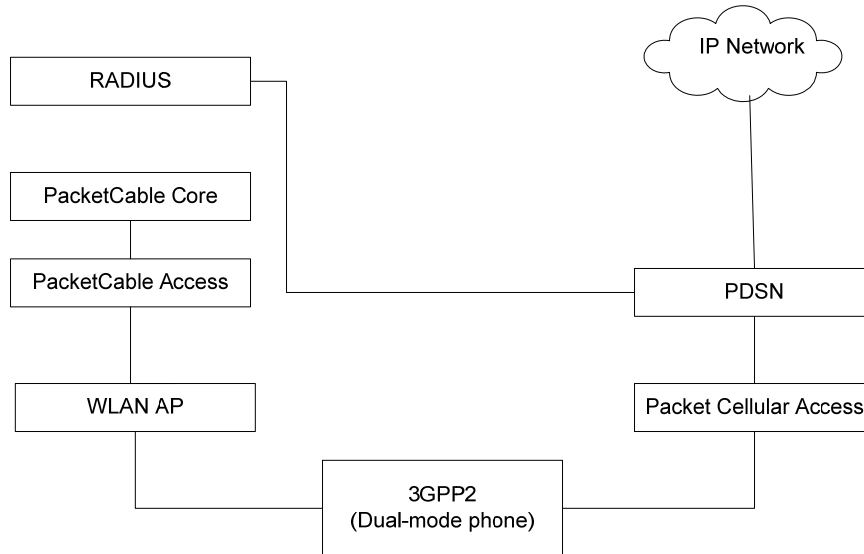

Figure 4 - PacketCable Interfaces to 3GPP2 Packet Cellular Networks

Table 4 summarizes the interfaces used for 3GPP packet cellular integration.

Table 4 - PacketCable Interfaces to 3GPP2 Packet Cellular Networks

Interface	PacketCable Functional Components	Description
3GPP2 Pi interfaces	3GPP2 RADIUS server and PDSN	Transfers subscription data and supports user authentication to support packet cellular network roaming over this RADIUS interface.
3GPP2 packet air interface	Dual-mode wireless UE and packet cellular network	Access and service per 3GPP2 packet cellular air interface specs.

5.4.5 Integration with 3GPP Accounting

5.4.5.1 3GPP circuit switched charging

[TS 32.250] defines the charging architecture and functionality of the 3GPP CS domain. CS domains that support PacketCable roaming subscribers will likely follow this specification.

For VCC the executed CAMEL services will be indicated in the CDRs. Protocol level details for these CDRs have not yet been standardized within 3GPP. (See out of scope list in Appendix IV).

It is expected that the CS domain will be capable of exchanging CDRs according to the Transferred Account Procedure as defined by the GSM Association in TD.57 [TD.57].

5.4.5.2 3GPP packet-switched charging

[TS 32.251] defines the charging architecture and functionality of the 3GPP PS domain. PS domains that support PacketCable roaming subscribers may roam will likely follow this specification.

It is expected that the PS domain will be capable of exchanging CDRs according to the Transferred Account Procedure as defined by the GSM Association in TD.57 [TD.57].

5.4.5.3 Impact on PacketCable

PacketCable supports terminals that can be used in 3GPP CS and PS networks. These CS and PS networks can be owned by the PacketCable operator or used in a MVNO agreement. Further, PacketCable subscribers will want to roam in CS and PS networks of other operators in different countries. For all these scenarios, the CS and PS operator will want to charge the use of the network resources to this subscriber's PacketCable operator. Therefore, inter-operator charging needs to be supported by PacketCable.

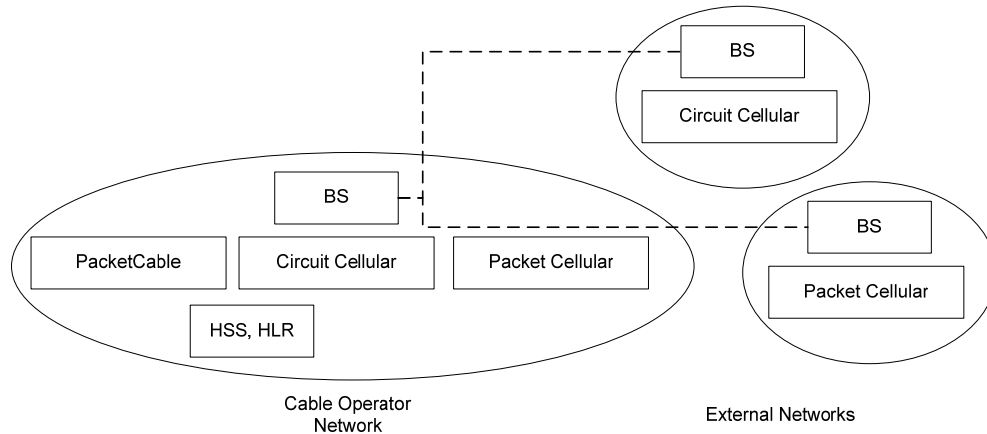

Figure 5 - Scenario 1: PacketCable operator owns a CS/PS network

If the PacketCable operator owns a CS/PS network, its Billing System (BS) takes care of the charging records received from all its networks. So as long as a PacketCable subscriber originates or terminates a call while roaming in one of these networks, the billing of these calls stays in the operator's realm.

If this operator's subscribers roam into CS/PS networks of other operators, these networks will send CDRs for being able to charge for calls that are originated from or terminated to PacketCable subscribers while roaming in this CS domain or for PS usage. Exchanging CDRs will follow the Transferred Account Procedure as defined by the GSM Association in TD.57 [TD.57].

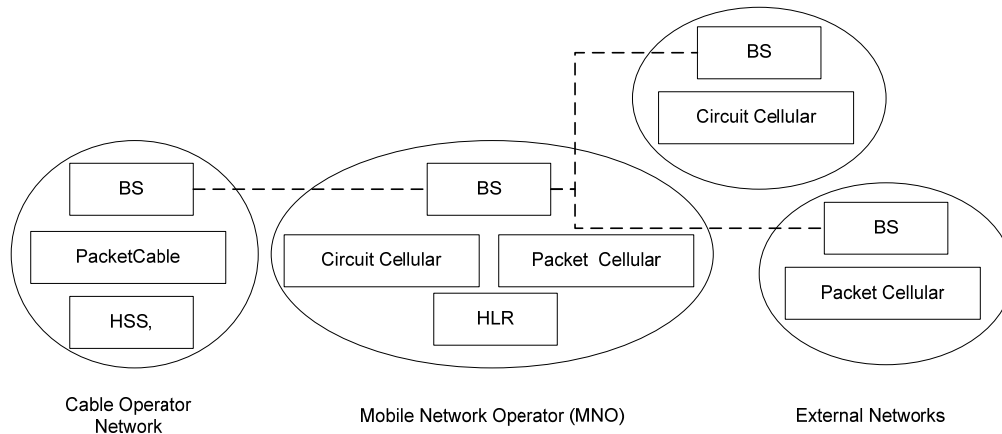

Figure 6 - Scenario 2: PacketCable operator is a CS/PS MVNO hosted by another MNO

If the PacketCable operator is a CS/PS MVNO hosted by another MNO, the operator receives billing information from the MNO that sells the PacketCable operator the CS/PS service. The way of billing can be re-used for the

cases where PacketCable subscribers roam to CS/PS networks other than the MNO's, as the MNO will receive the CDRs from these other CS/PS networks.

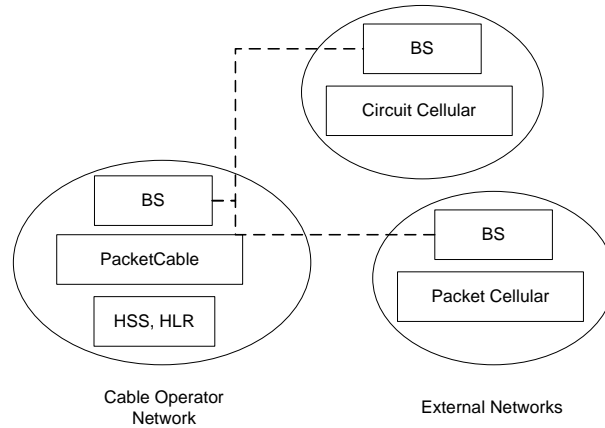

Figure 7 - Scenario 3: PacketCable operator is a full CS/PS MVNO

If the PacketCable operator is a full CS/PS MVNO that owns a CS/PS HLR, calls originating/terminating in a CS/PS network for one of its PacketCable subscribers always are accounted by these external networks and need to be charged to the PacketCable operator. Exchanging CDRs needs to follow the Transferred Account Procedure as defined by the GSM Association in TD.57 [TD.57].

5.4.6 Integration with 3GPP2 Accounting

5.4.6.1 3GPP2 circuit and packet-switched CDRs and protocols

3GPP2 CDR specifications, protocols, and procedures are defined in document N.S0026-A Wireless Radio Telecommunication Intersystem Non-Signaling Data Communication DMH Rev A (Data Message Handler) [N.S0026-A].

Due to the complexity and detail of this document, it was seldom implemented in practice. Instead, a simpler proprietary system was implemented and is in effect today. CIBER (Cellular Intercarrier Billing Exchange Roamer) records were developed by the CIBERnet (www.cibernet.com) company and are the defacto standard CDR data format. Exactly how the CDR file transfer happens between carriers and clearing houses is subject to privately negotiated agreements. The details of the data transfer methods are outside of the scope of this document.

CIBER records specify the fields, formats, and policies required to convey roaming network utilization. CIBER record description is identified as follows at www.cibernet.com.

CIBER records use System IDs and Billing IDs to identify record batches. Carriers are identified by unique SID/BID pairs, whereas, end users are identified using a combination of Mobile Identification Number (MIN) and Electronic Serial Number (ESN).

Typically, a Visited carrier's record batch is forwarded to the Visited carrier's clearing house which in turn manipulates the data records as needed and forwards the batch on to the Home carrier's clearing house for additional processing. The Home carrier clearing house then transfers the files to the Home carrier for final processing and payment.

5.4.6.2 3GPP2 IMS CDRs and protocol

IMS charging is covered in documents:

- 3GPP2 X.S0013-007-A v1.0 All-IP Core Network Multimedia Domain: IP Multimedia Subsystem - Charging Architecture [X.S0013-007].
- 3GPP2 X.S0013-008-A v1.0 All-IP Core Network Multimedia Domain: Offline Accounting Information Flows and Protocols [X.S0013-008].
- 3GPP2 X.S0013-000-A v1.0 All-IP Core Network Multimedia Domain: Overview [X.S0013-000].

X.S0013-007-A [X.S0013-007] documents a high-level outline of the charging architecture. IMS network nodes report accounting information collected via SIP or ISUP messages. Diameter is used between IMS nodes and AAA.

At a very high level, the document indicates that charging information is traditionally exchanged between billing systems via BS to BS likely through the use of CIBER records as indicated above. The document also outlines a real-time scenario whereby visited and home network operator AAA servers interface directly. However, no detail is given to the specifics of how this data exchange is engineered.

X.S0013-008-A [X.S0013-008] defines Off-line charging message flows and types, message formats, and Attribute Value Pairs (AVP) in detail.

PacketCable will interface with the 3GPP2 IMS infrastructure accounting and billing through the architecture and methods outlined in the above documents or through CIBER records as with the legacy CS and PS CDMA infrastructure, whichever is ultimately implemented in practice.

6 NORMATIVE REFERENCE APPLICATION

6.1 Tailoring of PKT-SP-24.229 for Circuit Cellular Integration

[PKT 24.229] is a delta specification with respect to [PKT 24.229]. For support of Cellular Integration, the following optional capabilities in [PKT 24.229] are made mandatory:

- Support of P-Access-Network-Info header
- Support of P-Associated-URI

6.1.1 P-Access-Network-Info

[PKT 24.229] makes inclusion of the P-Access-Network-Info header optional where the procedures detail its use. However, PacketCable UEs supporting Cellular Integration MUST provide a P-Access-Network-Info header when the [PKT 24.229] procedures specify its inclusion.

If the UE is accessing the PacketCable network via residential WiFi, the UE MUST insert a P-Access-Network-Info header indicating the appropriate WiFi value (e.g., [IEEE 802.11]).

Procedures associated to the use of the P-Access-Network-Info header (e.g., usage of different SIP Timers, SIP signaling compression) are as specified in [PKT 24.229].

6.1.2 P-Associated-URI

Support of the P-Associated-URI header within a UE is made optional in [PKT 24.229]. For support of Cellular Integration, UEs MUST support the use of the P-Associated-URI header and the associated procedures specified in [PKT 24.229].

6.2 Network Address Translation Firewall Traversal

PacketCable UEs supporting cellular integration MUST follow the ICE and Outbound NAT/firewall traversal requirements in and [PKT 24.229] when accessing the PacketCable network via the Gm interface.

6.3 Security

The security specifications for PacketCable 2.0 are provided by the following documents:

- [PKT 33.203]
- [PKT 33.210]
- [PKT 33.220]

The UE MUST support all of the requirements defined within [PKT 33.203] and [PKT 33.220]. The VCC AS MUST support all of the requirements defined within [PKT 33.210].

Note: Many of the security mechanisms are optional in the PacketCable specifications. It is for further study if any of the optional security mechanisms contained in these specifications are mandatory for the UE and VCC AS.

6.4 Codecs

The codec requirements applicable to UEs supporting cellular integration are built on the basis of [CODEC-MEDIA], which provides general codec recommendations for PacketCable applications with additional consideration to ensure compatibility with 3GPP/3GPP2 codec offerings [TS 26.235] and [TS 26.235].

For the current release of this specification, only audio codecs are considered; the video-codec requirements for cable/wireless integration are out of scope of this present specification.

For circuit-switched operation, a 3GPP-UE MUST support the 3GPP mandated codecs identified in reference [TS 26.103] and also support the codec selection procedures defined in reference [TS 24.008].

For circuit-switched operation, a 3GPP2-UE MUST support the 3GPP2 mandated codecs identified in reference [C.S0014].

For PacketCable cable wireless integration, the UE MUST support all requirements specified for the above codecs in [CODEC-MEDIA]. The normative references associated with all above codecs are included in [CODEC-MEDIA].

7 CELLULAR INTEGRATION REQUIREMENTS

7.1 General Requirements

Cellular requirements are organized in modular sets that can be deployed individually or in combinations. Each set realizes a specific set of services. Requirements are placed on the PacketCable network and PacketCable wireless devices. The variety of wireless devices is identified in Section 7.8.

Requirements are organized around the following service sets:

- Cable Operator controlled HLR, AuC and cellular subscriptions for network roaming onto 3GPP circuit and packet cellular networks
- Cable Operator controlled HLR, RADIUS server and cellular subscriptions for network roaming onto 3GPP2 circuit and packet cellular networks
- Continuous voice and features across PacketCable and 3GPP circuit cellular networks
- Continuous voice and features across PacketCable and 3GPP2 circuit cellular networks

A PacketCable network that supports network roaming onto 3GPP circuit and packet cellular networks with a Cable Operator controlled cellular subscription conforms to the requirements in Section 7.2.1.

A PacketCable network that supports network roaming onto 3GPP2 circuit and packet cellular networks with a Cable Operator controlled cellular subscription conforms to the requirements in Section 7.2.2.

A PacketCable network that supports continuous voice and features across 3GPP circuit cellular and PacketCable access networks conforms to the requirements called out in Sections 7.3, 7.5, 7.6 and 7.7.

A PacketCable network that supports continuous voice and features across 3GPP2 circuit cellular and PacketCable access networks conforms to the requirements called out in Sections 7.4, 7.5, 7.6 and 7.7.

A PacketCable network that supports Push-to-talk over cellular and cable networks conforms to the requirements in Section 7.10.

7.2 Home Location Register for Circuit and Packet Cellular Roaming

7.2.1 PacketCable Support for 3GPP HLR and AuC

7.2.1.1 Support of Circuit Cellular Interoperability

For support of Circuit Cellular Interoperability, PacketCable will either include or have access to an HLR with an AuC node (as specified in sections 4.1.1.1.1 and 4.1.1.1.2 of [TS 23.002]). The HLR MUST support:

- MAP interfaces C and D and associated procedures as specified in [TS 29.002] and [TS 23.002] sections 6.4.1.2 and 6.4.1.3 respectively.
- Circuit Cellular Subscription Data as specified in [PKT 23.008] Table 5.1 under column HLR.

Additionally, in order to support Voice Call Continuity, the 3GPP HLR MUST support CAMEL triggers as defined within [TS 29.078].

7.2.1.2 Support of Packet Cellular and Wireless IP Access Interoperability

For support of 3GPP Packet Cellular Interoperability, PacketCable will either include or have access to an HLR with an AuC node (as specified in section 4.1.1.1.1 and 4.1.1.1.2 of [TS 23.002]. The HLR MUST support:

- MAP interfaces Gr and Gc and associated procedures as specified in [TS 29.002], [TS 23.002] sections 6.4.2.1 and 6.4.2.3 respectively and [TS 23.060].
- Packet Cellular Subscription Data as specified in [PKT 23.008] Table 5.2 under column HLR.

HLR conditionally includes subscribed charging characteristics as per [PKT 23.008] section 2.19, e.g., whether the subscriber is normal, prepaid or flat rate.

7.2.2 PacketCable Support for TIA HLR and RADIUS Server

7.2.2.1 Support of Circuit Cellular Interoperability

The HLR is part of the 'legacy' or TDM side of the 3GPP2 architecture as defined within [S.R0005].

Access to the HLR requires support of the interfaces and procedures defined for reference points C and D. Access to the AC (Authentication Centre) requires support for the interfaces defined for reference point H although it is expected that this function is subsumed into the HLR. All of these references are defined by ANSI-41/TIA-41 [N.S0005].

For support of 3GPP2 circuit cellular interoperability PacketCable will either include or have access to a HLR/AuC. The HLR with the AuC MUST support:

- MAP interfaces C and D and associated procedures as specified within [N.S0005]
- Registration procedures defined within [N.S0005]
- Automatic roaming procedures defined within [N.S0005]

Additionally, in order to support Voice Call Continuity, the HLR MUST support WIN (Wireless Intelligent Network) triggers as defined within [N.S0013].

7.2.2.2 Support for Packet Cellular and Wireless IP Interoperability

To support packet-switched cellular interoperability PacketCable will either include or have access to a network conforming to the architecture as defined within [P.R0001]. The PacketCable AAA server MUST support:

- The RADIUS interface Pi and associated procedures as defined within [TIA/IS-835.2].
- The P-P interface and mobility procedures as defined within [TIA/IS-835.2] section 4.

Additionally, the AAA function providing the Pi interface MUST at a minimum support:

- The RADIUS attributes defined in [TIA/IS-835.2] Table 1.
- The RADIUS attributes and Vendor Specific Attributes defined in [TIA/IS-835.2] Sections 4 and 5.

7.3 Voice Call Continuity for 3GPP Circuit Cellular Networks

3GPP-VCC is a PacketCable capability that allows a VCC User to receive a well-defined set of the PacketCable features, as defined later in this specification, while connected via a 3GPP-UE (as specified in Section 7.8 below). When the 3GPP-UE moves between circuit-switched cellular and PacketCable coverage, the 3GPP-VCC capability provides seamless mobility where the user does not experience a noticeable discontinuity in service. The remainder of this section provides specifications for the 3GPP-UE and the 3GPP VCC application server that are needed to support 3GPP-VCC service.

This section defines VCC between the PacketCable network and a 3GPP circuit-switched cellular network (also called GSM). The following subsections specify the PacketCable 3GPP-VCC feature operation. An operator can choose to implement only the 3GPP-VCC (see section 7.3) or 3GPP2-VCC (see section 7.4) specific requirements. If so, the PacketCable network will only support VCC with either GSM or CDMA1x circuit cellular networks.

The 3GPP-VCC specification is based on the 3GPP specifications [TS 23.206] and [TS 24.206]. In order to support the 3GPP-VCC capability, the network will contain a 3GPP-VCC AS and require a VCC Client in the 3GPP-UE. The details are specified in the following sections.

7.3.1 General Requirements

A PacketCable network that supports the 3GPP-VCC capability contains a GSM HLR function or has access to a cellular operator's GSM HLR function for VCC-capable subscribers.

A PacketCable network that supports the 3GPP-VCC capability contains the 3GPP-VCC AS as specified in this document.

To support the 3GPP-VCC capability for a user, the user's UE supports 3GPP-UE functions as specified in this document. The subscriber profile in the HLR needs to allow the 3GPP-VCC capability for this user.

Where [TS 23.206], and [TS 24.206] reference [TS 23.228], the reference MUST be replaced with [PKT 23.228].

Where [TS 23.206], and [TS 24.206] reference [TS 23.228], the reference MUST be replaced with [PKT 24.229].

[TS 24.206] references the general IP Multimedia (IM) Core Network (CN) subsystem. For this specification, the IM CN subsystem refers to the PacketCable system.

7.3.2 Configuration Considerations

To deploy 3GPP-VCC, a number of configuration items need to be considered, as discussed in this section.

The 3GPP-VCC capability is only available if the user has a 3GPP-UE and if the subscriber profile allows the 3GPP-VCC capability for this user.

- The HSS stores initial Filter Criteria (iFC), constructed in a manner that supports detection of the VCC service point trigger, in the proper order relative to other filter criteria as configured for other PacketCable services. For call originations, the 3GPP-VCC AS is invoked first, prior to other originating PacketCable services. For call terminations, the 3GPP-VCC AS is invoked last, after other terminating PacketCable services. This is controlled via the Priority element of the iFC settings.
- Appropriate feature data is configured in the subscriber profile as maintained in the 3GPP HLR. This data identifies which circuit-switched cellular features are to be enabled or disabled for proper VCC operation, as discussed in Section 7.6. Interactions between VCC and other features (beyond those discussed in Section 7.6) are outside the scope of this document.

- The 3GPP HLR stores the appropriate CAMEL trigger(s) as chosen for VCC, for VCC subscribers. (The associated information also contains address information that is used to direct the associated queries from the MSC to the VCC AS.) Interactions between the VCC trigger(s) and MSC based features or other triggers (as used for other CAMEL based services) are outside the scope of this document.
- The HSS or VCC AS maintains VCC subscriber data, used to control the invocation of appropriate VCC procedures for authorized VCC subscribers.

The IMRN and VDI are provisioned in the HSS as Public Service Identities that allow routing of SIP messages directed to them to the 3GPP-VCC AS. This information is used by the I-CSCF to route messages directly to the 3GPP-VCC AS via the Ma reference point.

The IMRN is part of a pool of numbers that are assigned by the VCC AS when the 3GPP-UE originates a call from the CS domain. The IMRN is only used during call setup, and the pool can be engineered based on the number of simultaneous call setups that the 3GPP-VCC AS can support.

To promote media optimization for CS call originations (i.e., selection of an MGC in the geographic vicinity of the VCC subscriber), these IMRN assignments can be based on specific MSC identities or other geographic information. This is discussed in Appendix I.4.

The VDN and VDI are used for domain transfer call originations. They will be passed to the 3GPP-UE as part of the provisioning process. The VDN need not be a routable telephone number, since the VDN will be carried in a CAMEL trigger to be used as an input in translating the VDN to a routable IMRN.

To promote media optimization for CS call terminations, the BGCF can maintain appropriate translations (i.e., to select an MGC in the geographic vicinity of the VCC subscriber's current visited network, for routing of calls destined to a CSRN). This is discussed in Appendix I.6.

7.3.3 3GPP-UE Requirements

A 3GPP-UE supports the capabilities as defined in Section 7.8. This functionality is an extension of the VCC client functionality as defined in [TS 23.206] with the procedures as specified in [TS 24.206].

[TS 24.206] does not specify how the VDI and VDN are provisioned in the VCC UE. For PacketCable, the VDI and VDN in the 3GPP-UE MUST be provisioned via the standard PACM mechanism. The VDN and VDI formats are described below.

Table 5 - Configurable 3GPP-UE VDN and VDI Values

Data	Type	Persistence	Scope	Stored by	Written by	Read by	PACM Requirement
3GPP VDI	String	Non-volatile	Per UE	UE	XDS	XDS, UE	Mandatory
3GPP VDN	String	Non-volatile	Per UE	UE	XDS	XDS, UE	Mandatory

The VDN is a configurable dialed digit string to be used by the 3GPP-UE to create an origination request for PacketCable-to-CS domain transfers. It contains a variable number of characters. Valid characters are '0' - '9', '#', and '*'. The VDN is not required to be a routable number.

The VDI is a configurable SIP or TEL URI that represents the Request-URI to be used by the UE to create an INVITE to request for CS-to-PacketCable domain transfers.

7.3.3.1 Service Registration

A dual-registration model is used for supporting the 3GPP-VCC Capability, whereby the 3GPP-UE MAY be simultaneously registered in both the CS and PacketCable domains.

Consistent with the general requirements presented in Section 7.3.1:

- When registering, re-registering and deregistering in the Cellular Network, the 3GPP-UE MUST conform to the IMSI attach and detach rules and procedures as specified in [TS 24.008].
- When registering, re-registering and deregistering in the PacketCable domain, the 3GPP-UE MUST conform to the UE registration and deregistration rules and procedures as specified in [PKT 24.229].

The 3GPP-UE MUST be registered in the Cellular Network prior to doing a domain transfer to the CS domain.

The 3GPP-UE MUST be registered in the PacketCable domain prior to doing a domain transfer to the PacketCable domain.

The corresponding end-to-end message flows are illustrated in Appendix I.1 (UE Registration in PacketCable Domain) and in Appendix I.2 (UE Registration in CS Domain).

7.3.3.2 Voice Call Origination

Consistent with the general requirements presented in Section 7.3.1:

- When originating a voice call in the CS domain, the 3GPP-UE MUST conform to standard CS domain UE voice call origination rules and procedures as specified in [TS 24.008].
- When originating a voice call in the PacketCable domain, the 3GPP-UE MUST conform to standard PacketCable domain UE voice call origination rules and procedures as specified in [PKT 24.229].

Further details on 3GPP-VCC voice call origination are defined in [TS 23.206] and specified in [TS 24.206].

The corresponding end-to-end call flows are illustrated in Appendix I.3 and in Appendix I.4.

7.3.3.3 Voice Call Termination

Consistent with the general requirements presented in Section 7.4.3:

- When terminating a voice call in the CS Domain, the 3GPP-UE MUST conform to standard CS domain UE voice call termination rules and procedures as specified in [TS 24.008].
- When terminating a voice call in the PacketCable domain, the 3GPP-UE MUST conform to standard PacketCable domain UE voice call termination rules and procedures as specified in [PKT 24.229].

Further details on VCC voice call termination are defined in [TS 23.206] and specified in [TS 24.206].

The corresponding end-to-end call flows are illustrated in Section I.5 and in Section I.6.

7.3.3.4 Domain transfer from PacketCable domain to Circuit-Switched Cellular domain

The 3GPP-UE determines when to initiate a domain transfer from the PacketCable domain to the CS domain. The 3GPP-VCC AS decides whether to accept and execute the request. Domain transfer requests from the PacketCable

domain to the CS domain entail basic CS voice call origination processing, but the 3GPP-UE populates the PACM provisioned VDN as the called party address of the outgoing origination request.

The 3GPP-UE supports domain transfer from the IMS domain to the CS domain as defined in [TS 23.206] and MUST follow the roles for domain transfer of a call from the IM CN subsystem to the CS domain for VCC UE as specified in [TS 24.206].

The corresponding end-to-end call flow is illustrated in Appendix I.8.

7.3.3.5 Domain transfer from Circuit-Switched Cellular domain to PacketCable domain

The 3GPP-UE determines when to initiate a domain transfer from the CS domain to the PacketCable domain. The 3GPP-VCC AS decides whether to accept and execute the request. Domain transfer requests from the CS domain to the PacketCable domain entail basic PacketCable voice call origination processing, but the 3GPP-UE populates the PACM provisioned VDI in the Request-URI and in the To header field of the outgoing INVITE.

The 3GPP-UE supports domain transfer from the CS domain to the IMS domain as defined in [TS 23.206] and MUST follow the roles for domain transfer of a call from the CS domain to the IM CN subsystem for VCC UE as specified in [TS 24.206].

The corresponding end-to-end call flow is illustrated in Appendix I.7.

7.3.3.6 Support of Telephony Service Execution - Hybrid Model

The Hybrid Telephony Service execution model defines the interaction of telephony services with VCC. The 3GPP-UE conforms to the procedures for telephony service execution - hybrid model as specified in Section 7.6 and 7.7.

This specification supersedes any telephony or supplementary service specifications for the 3GPP-UE contained in [TS 23.206] and [TS 24.206].

7.3.4 3GPP-VCC AS Requirements

The 3GPP-VCC AS MUST conform to the PacketCable rules and procedures for Application Servers as specified in [PKT 24.229].

In addition to the reference points included in [TS 23.206], the 3GPP-VCC AS SHOULD include the MAP interface to the HLR (as shown in Table 1).

The 3GPP-VCC-AS SHOULD take on the GMSC role to retrieve an MSRN (CSRN) from the VMSC, which requires the MAP interface procedures as specified in [TS 29.002]. Note that the MSRN used for VCC call routing is referred to as the CSRN in VCC specifications. If the 3GPP-VCC AS does not include the MAP interface, the PacketCable network needs to be configured to route all CS domain calls to a GMSC which will then retrieve the CSRN. The informative call flow in Appendix I.6 explains how bearer path optimization can occur when the 3GPP-VCC AS retrieves the CSRN.

Two CAMEL related reference points are shown in [TS 23.206]: VMSC - gsmSCF and gsmSCF - CAMEL Service. If a PacketCable network supports the 3GPP-VCC capability, it MUST either contain a gsmSCF function or have access to a cellular operator's gsmSCF function. The gsmSCF - CAMEL Service reference point as defined in [TS 23.206] is vendor specific.

Note: If the VMSC - gsmSCF reference point is not supported in the roaming network, then the VCC UE will not be able to do domain transfer and will not be able to execute some of the telephony services - hybrid model, as specified Section 7.6, while attached to that GSM network.

[TS 23.206] splits the VCC Application into multiple functions. Within PacketCable, the VCC Application is considered as a single function, the 3GPP-VCC AS, and a decomposition of the 3GPP-VCC AS into multiple functions is not defined.

[TS 24.206] allows the VCC Application to be split into multiple functions. Within PacketCable, the VCC Application is considered as a single function, the 3GPP-VCC AS, and a decomposition of the 3GPP-VCC AS into multiple functions is not defined.

7.3.4.1 Service Registration for 3GPP-UE

The 3GPP-VCC AS MUST support Third Party registration (i.e., receipt and processing of SIP REGISTER from the S-CSCF) via the ISC interface as specified in [PKT 24.229].

The 3GPP-VCC AS MUST conform to the specific IMS registration procedures defined in [TS 23.206] and specified in [TS 24.206].

The corresponding end-to-end call flows are illustrated in Appendix I.1 and in Appendix I.2.

7.3.4.2 Voice Call Origination from 3GPP-UE

The 3GPP-VCC AS supports PacketCable voice call originations for 3GPP-UE originated voice calls, when the 3GPP-UE is in the PacketCable domain. The 3GPP-VCC AS supports CS voice call originations for a 3GPP-UE when the 3GPP-UE is in the CS domain.

The 3GPP-VCC AS supports voice call originations as defined in [TS 23.206] and MUST follow the roles for call origination for VCC Application as specified in [TS 24.206].

If the 3GPP-VCC AS supports media optimization, then the 3GPP-VCC AS SHOULD be able to allocate IMRNs (for CS voice call originations) in a location-specific manner (e.g., taking into account the identity / location of the MSC that is currently serving the 3GPP-UE).

The corresponding end-to-end call flows are illustrated in Appendix I.3, and in Appendix I.4.

7.3.4.3 Voice Call Termination to 3GPP-UE

The 3GPP-VCC AS supports PacketCable domain voice call terminations for the 3GPP-UE, when the 3GPP-UE is in the PacketCable domain.

The 3GPP-VCC AS supports CS domain termination of voice calls to the 3GPP-UE when it is in the CS domain.

The 3GPP-VCC AS supports voice call terminations as defined in [TS 23.206] and MUST follow the roles for call termination for VCC Application in the PacketCable domain as specified in [TS 24.206]. For 3GPP-UE voice call terminations in the CS domain, this entails 3GPP-VCC AS reception and processing of an associated SIP INVITE request due to terminating filter criteria, the subsequent generation of an associated MAP SRI message to the HLR, and processing of the associated response.

[TS 24.206] covers the case where the VCC user's telephone number terminates in either the CS or the IMS domain. For PacketCable, the PacketCable network is configured for the subscriber to be homed in the PacketCable network such that calls terminate the VCC user's telephone number in the PacketCable domain. The 3GPP VCC AS is not required to support user telephone numbers homed in the CS domain as discussed in [TS 23.206] and [TS 24.206].

The corresponding end-to-end call flows are illustrated in Appendix I.5 and in Appendix I.6.

7.3.4.4 Domain transfer from PacketCable domain to Circuit-Switched Cellular domain

The 3GPP-VCC AS supports 3GPP-UE originations from the CS domain to initiate a domain transfer from the PacketCable to the CS domain. While [TS 24.206] only specifies domain transfers for a single call, PacketCable extends this for certain multiple call scenarios as is specified in Section 7.7.

The 3GPP-VCC AS supports domain transfer from the PacketCable domain to the CS domain as defined in [TS 23.206] and MUST follow the roles for domain transfer of a call from the IM CN subsystem to the CS domain for VCC Application as specified in [TS 24.206].

The corresponding end-to-end call flow is illustrated in Appendix I.8.

7.3.4.5 Domain transfer from Circuit-Switched Cellular domain to PacketCable domain

The 3GPP-VCC AS supports 3GPP-UE originations from the PacketCable domain to initiate a domain transfer from the CS to the PacketCable domain. While [TS 24.206] only specifies domain transfers for a single call, PacketCable extends this for certain multiple call scenarios as is specified in Section 7.7.

The 3GPP-VCC AS supports domain transfer from the CS domain to the PacketCable domain as defined in [TS 23.206] and MUST follow the roles for domain transfer of a call from the CS domain to the IM CN subsystem for VCC Application as specified in [TS 24.206].

The corresponding end-to-end call flow is illustrated in Appendix I.7.

7.3.4.6 Support of Telephony Service Execution - Hybrid Model

The 3GPP-VCC AS conforms to the procedures for telephony service execution - hybrid model as specified in Section 7.6 and 7.7.

This specification supersedes any telephony or supplementary service specifications for the VCC Application contained in [TS 23.206] and [TS 24.206].

7.3.4.7 Accounting

The 3GPP-VCC AS MUST generate offline accounting records over the Rf interface as specified in [PKT ACCT]. These records will be in addition to the normal accounting records that other PacketCable network elements are generating.

7.4 Voice Call Continuity for 3GPP2 Circuit Cellular Networks

3GPP2-VCC is a PacketCable capability that allows a 3GPP2 VCC User to receive a well-defined set of the PacketCable features, as defined later in this specification, while connected via a 3GPP2-UE (as specified in Section 7.8). When the 3GPP2-UE moves between CS cellular and PacketCable coverage, the 3GPP2-VCC capability provides seamless mobility where the user does not experience a noticeable discontinuity in service. The remainder of this section provides specifications for the 3GPP2-UE and the 3GPP2-VCC network elements that are needed to support 3GPP2-VCC service.

The current requirements are based on functionality as defined in [X.P0042-001] and [X.P0042-002].

7.4.1 General Requirements

This section presents overall 3GPP2 VCC architectural requirements and requirements that are applicable to network elements other than the 3GPP2-VCC AS and the 3GPP2-UE.

If a PacketCable network supports the 3GPP2-VCC capability, then it will contain the 3GPP2-VCC AS as specified in this document.

If a PacketCable network supports the 3GPP2-VCC capability, then it will either contain a 3GPP2 HLR function or have access to a cellular operator's 3GPP2 HLR function for 3GPP2-VCC-capable subscribers.

If a PacketCable network supports the 3GPP2-VCC capability, then the 3GPP2 VCC AS SHOULD use the Wireless Intelligent Network (WIN) option (as described in [X.P0042-001] to allow PacketCable CS voice call originations. The 3GPP2 MSC/VLR detects the necessary WIN trigger(s), as specified in [N.S0013]. WIN functionality is used to allow the 3GPP2-VCC AS to be inserted into the call flow signaling path for CS call originations, and enables the media optimization mechanism as illustrated in Appendix I.4.

If a PacketCable network supports the 3GPP2-VCC capability, then the WIN option (as described in [X.P0042-002]) SHOULD be used to allow domain transfer from the PacketCable domain to the CS domain. This enables consistency of procedures for PacketCable-to-CS domain transfer and CS call originations, as illustrated in Appendix I.8.

The use of pre-WIN triggers, as specified in [X.P0042-001] for CS voice call originations, is not required for PacketCable. The PacketCable network's 3GPP2 HLR is not required to support the arming of pre-WIN triggers. However, the cellular network operator can use this option if the cellular network does not support WIN. In this case, the cellular network's HLR performs any necessary mapping from the ANSI-41-D MAP OriginationRequest (ORREQ) message (from a pre-WIN MSC) to the standard WIN ORREQ message (to the 3GPP2-VCC AS). The use of pre-WIN triggers in this manner does not impact the 3GPP2-VCC AS functionality, as defined in this document. Behavior specifications for such a 3GPP2 HLR are outside the scope of this document.

If a PacketCable network supports the 3GPP2-VCC capability with a PacketCable operator's 3GPP2 HLR, then the PacketCable network's 3GPP2 HLR MUST support the arming of WIN triggers as specified in [N.S0013].

If a PacketCable network supports the 3GPP2-VCC capability, then the 3GPP2 HLR MAY support CS registration notifications via the ANSI-41 MAP interface as specified in [X.S0009]. This includes sending of ANSI-41 RegistrationNotification (REGNOT) and MSInactive (MSINACT) messages to the 3GPP2-VCC AS, as a mechanism for the 3GPP2-VCC AS to maintain registration-status information concerning the 3GPP2-UE.

[X.P0042-001] permits an intervening WIN SCP to reside between the 3GPP2-VCC AS and an MSC, for the exchange of WIN messages. The use of an intervening WIN SCP is not required for PacketCable 3GPP2-VCC, although such an intervening WIN SCP can be deployed by the cellular operator. The presence or absence of such an intervening WIN SCP does not impact the 3GPP2-VCC AS functionality as defined in this document. Behavior specifications for such an intervening WIN SCP are outside the scope of this document.

[X.P0042-001] and [X.P0042-002] reference a number of MMD documents. When applied for PacketCable 3GPP2-VCC, MMD references are replaced with PacketCable specifications as indicated in the following requirements.

- Where [X.P0042-001] and [X.P0042-002] reference [X.S0013-002], the reference MUST be replaced with [PKT 23.228].
- Where [X.P0042-001] and [X.P0042-002] reference [X.S0013-004] the reference MUST be replaced with [PKT 24.229].

7.4.2 VCC Configuration Considerations

To deploy 3GPP2-VCC, a number of configuration items need to be considered, as discussed in this section.

The 3GPP2-VCC capability is only available if the user has a 3GPP2-UE and if the subscriber profile allows the 3GPP2-VCC capability for this user.

- The HSS stores initial Filter Criteria (iFC), constructed in a manner that supports detection of the Service Point Trigger(s) for VCC, in the proper order relative to other filter criteria as configured for other PacketCable services. For call originations, the 3GPP2-VCC AS is invoked first, prior to other originating PacketCable services. For call terminations, the 3GPP2-VCC AS is invoked last, after other terminating PacketCable services. This is controlled via the Priority element of the iFC settings.
- Appropriate feature data is configured in the subscriber profile as maintained in the 3GPP2 HLR. This data identifies which circuit-switched cellular features are to be enabled or disabled for proper 3GPP2-VCC operation, as discussed in Section 7.6. Interactions between 3GPP2-VCC and other features (beyond those discussed in Section 7.6.) are outside the scope of this document.
- The 3GPP2 HLR stores the appropriate WIN trigger(s) as chosen for 3GPP2-VCC, for 3GPP2-VCC subscribers. (The associated TriggerAddressList information also contains address information that is used to direct the associated queries from the MSC to the 3GPP2-VCC AS.) Interactions between the 3GPP2-VCC trigger(s) and MSC-based features or other triggers (as used for other WIN-based services) are outside the scope of this document.
- The 3GPP2-VCC AS or HSS can maintain 3GPP2-VCC subscriber data (e.g., to control the invocation of appropriate 3GPP2-VCC procedures for authorized 3GPP2-VCC subscribers).

The IMS Routing Numbers (IMRNs) and VDI are provisioned in the HSS as Public Service Identities that allow routing of SIP messages directed to them to the 3GPP2-VCC AS. This information is used by the I-CSCF to route messages directly to the 3GPP2-VCC AS via the Ma reference point.

Network signaling translations enable the routing of MAP messages to PacketCable network elements. If SCCP Global Title Translation (GTT) procedures are used for routing of MAP query messages to PacketCable network elements, corresponding GTT data is configured to facilitate the routing of those messages. (Additional information concerning these transport signaling protocols can be found in 3GPP2 [X.S0004-511-E].)

Domain-transfer digits are configured in the 3GPP2-UE. These digit sequences can include service codes and VCC AS E.164 numbers, as discussed in [X.P0042-001] and [X.P0042-002]. The specific digits are established by the PacketCable operator and are outside the scope of this document. The digit string that is used for PacketCable-to-CS domain transfers is referred to as the VCC Domain Transfer Number (VDN). The value that is used for CS-to-PacketCable domain transfers is referred to as the VCC Domain Transfer URI (VDI). See further discussion in Section 7.4.3.

The above VDN and VDI values are configured in the 3GPP2-VCC AS. These values allow the 3GPP2-VCC AS to distinguish domain-transfer attempts from other call attempts. See further discussion in Section 7.4.4.

Pools of IMRN numbers are administered in the 3GPP2-VCC AS, and are used to enable the anchoring of calls at the 3GPP2-VCC AS. To promote media optimization for CS call originations (i.e., selection of an MGC in the geographic vicinity of the 3GPP2-VCC subscriber), the selection of a particular IMRN by the 3GPP2-VCC-AS can be based on specific MSC identities or other geographic information (as populated in the incoming WIN Query message). MSC routing translations can be used to route an outgoing call (directed to a particular IMRN) toward an appropriate MGC/MG. This is discussed in Appendix I.4.

To further promote media optimization for CS call terminations, the BGCF can maintain appropriate translations (i.e., to select an MGC in the geographic vicinity of the 3GPP2-VCC subscriber's current visited network, for routing of calls destined to a TLDN). This is discussed in Appendix I.6.

7.4.3 3GPP2-UE Requirements

General 3GPP2-UE requirements are specified in Section 7.8.

[X.P0042-001] does not specify how the VDN and VDI, used for domain transfer between the CS domain and the PacketCable domain, are provisioned in the 3GPP2-UE. For PacketCable, the 3GPP2-UE MUST support the configuration of VDN and VDI values (as discussed in Section 7.4.2) via the standard PACM mechanism. The VDN and VDI formats are described below.

Table 6 - Configurable 3GPP2-UE VDN and VDI Values

Data	Type	Persistence	Scope	Stored by	Written by	Read by	PACM Requirement
3GPP2 VDI	String	Non-volatile	Per UE	UE	XDS	XDS, UE	Mandatory
3GPP2 VDN	String	Non-volatile	Per UE	UE	XDS	XDS, UE	Mandatory

The VDN is a configurable dialed digit string to be used by the 3GPP2-UE to create an origination request for PacketCable-to-CS domain transfers. It contains a variable number of characters. Valid characters are '0' - '9', '#' and '*'. The VDN is not required to be a routable number.

The VDI is a configurable SIP or TEL URI that represents the Request-URI to be used by the 3GPP2-UE to create an INVITE request for CS-to-PacketCable domain transfers.

7.4.3.1 3GPP2-VCC Service Registration

A dual-registration model is used for supporting the 3GPP2-VCC Capability, whereby the 3GPP2-UE MAY be simultaneously registered in both the CS and PacketCable domains.

The 3GPP2-UE MUST conform to the Registration procedures defined in [X.P0042-001] and the roles for registration in the MMD subsystem specified in [X.P0042-002], with exceptions as stated below.

- A 3GPP2-UE is not required to register via HRPD access. Only the WLAN option is required.
- A 3GPP2-UE is not required to indicate its capabilities (e.g., whether it is 3GPP2-VCC-capable) upon registration in the PacketCable domain.
- A 3GPP2-UE is not required to re-register if it enters a new IP-CAN coverage area where the negotiated VoIP capabilities are different from those negotiated in the previous IP-CAN coverage area.
- A 3GPP2-UE is not required to send an SMS (via the CS network) to the 3GPP2-VCC AS when the 3GPP2-UE detects that its PacketCable connection is temporarily unavailable.

The corresponding end-to-end message flows are illustrated in Appendix I.1 (UE Registration in PacketCable Domain) and in Appendix I.2 (UE Registration in CS Domain).

7.4.3.2 3GPP2-UE Voice Call Origination

The 3GPP2-UE MUST conform to the call origination procedures defined in [X.P0042-001] and the roles for call origination specified in [X.P0042-002].

The corresponding end-to-end call flows are illustrated in Appendix I.3 (UE Origination Call Setup in PacketCable Domain) and in Appendix I.4 (UE Origination Call Setup in CS Domain).

7.4.3.3 3GPP2-UE Voice Call Termination

The 3GPP2-UE MUST conform to the call termination procedures defined in [X.P0042-001] and the roles for call termination specified in [X.P0042-002].

The corresponding end-to-end call flows are illustrated in Appendix I.5 and in Appendix I.6.

7.4.3.4 3GPP2-UE Domain Transfer from PacketCable domain to Circuit-Switched Cellular domain

The 3GPP2-UE MUST conform to the WLAN VoIP to 1x CS domain transfer procedures defined in [X.P0042-001] and the roles for domain transfer of a call from the MMD subsystem to the CS domain specified in [X.P0042-002], with the following modifications:

- A 3GPP2-UE is not required to support the HRPD IMS to CS domain transfer procedures as described in [X.P0042-001].
- A 3GPP2-UE is not required to support the non-trigger-based IMS to CS domain transfer procedures as described in [X.P0042-001].

A 3GPP2-UE supports the configuration of a VDN for PacketCable-to-CS domain transfers, as discussed in Section 7.4.2. The 3GPP2-UE MUST populate the VDN as the called party address for PacketCable-to-CS domain transfer attempts.

The corresponding end-to-end call flow is illustrated in Appendix I.8 (PacketCable to CS VCC Domain Transfer Procedure for 2 Party Call).

7.4.3.5 3GPP2-UE Domain Transfer from Circuit-Switched Cellular domain to PacketCable domain

The 3GPP2-UE MUST conform to the 1x CS to WLAN domain transfer procedures defined in [X.P0042-001] and the roles for the domain transfer of a call from the CS to the MMD specified in [X.P0042-002].

A 3GPP2-UE supports the configuration of a VDI for CS-to-PacketCable domain transfers procedures, as discussed in Section 7.4.2. The 3GPP2-UE MUST populate the VDI in the Request-URI and in the To header field of the outgoing INVITE for CS-to-PacketCable domain transfer attempts.

The corresponding end-to-end call flow is illustrated in Appendix I.7.

7.4.3.6 3GPP2-UE Support of Telephony Service Execution - Hybrid Model

Additional 3GPP2-UE requirements, for supporting telephony service execution (with the hybrid service execution model) are specified in Sections 7.6 and 7.6.

This specification supersedes any telephony or supplementary service specifications for the 3GPP2-UE contained in [X.P0042-001] and [X.P0042-002].

7.4.4 3GPP2-VCC AS Requirements

The 3GPP2-VCC AS MUST conform to the PacketCable rules and procedures for Application Servers as specified in [PKT 24.229].

The 3GPP2-VCC AS MUST support the ISC and Ma reference points as specified in [PKT 24.229].

The 3GPP2-VCC AS MAY support the Sh reference point as specified in [TS 29.328]. No specific requirement for this interface has been identified for the 3GPP2-VCC AS.

The 3GPP2-VCC AS MUST support the MAP interface as specified in [N.S0005]. For 3GPP2-VCC, this capability is used to support the LocationRequest (LOCREQ) operation.

The 3GPP2-VCC AS MUST support the WIN interface as specified in [N.S0013]. For 3GPP2-VCC, this capability is used to support the OriginationRequest (ORREQ) operation.

The 3GPP2-VCC AS MUST distinguish between various incoming SIP INVITE messages. The corresponding 3GPP2-VCC AS procedures are specified in [X.P0042-002]. To distinguish these messages for PacketCable, the 3GPP2-VCC AS MUST be able to detect the presence of the VDI, as discussed in Section 7.4.2.

The 3GPP2-VCC AS is considered as a single function. No further decomposition of the 3GPP2-VCC AS into sub-functions is defined.

7.4.4.1 3GPP2-VCC AS Service Registration

The 3GPP2-VCC AS MUST conform to the registration procedures defined in [X.P0042-001] and the roles for registration in the MMD subsystem specified in [X.P0042-002], with the following exception:

- The 3GPP2-VCC AS is not required to receive an SMS (via the CS network) from a 3GPP2-UE, when the 3GPP2-UE detects that its PacketCable connection is temporarily unavailable.

The 3GPP2-VCC AS MAY support CS registration notifications of 3GPP2-UEs via the MAP interface as specified in [X.S0009], as a mechanism to track the CS registration status of 3GPP2-UEs. This includes reception of RegistrationNotification (REGNOT) and MSInactive (MSINACT) messages from the HLR.

The corresponding end-to-end call flows are illustrated in Appendix I.1 and in Appendix I.2.

7.4.4.2 3GPP2-VCC AS Voice Call Origination from 3GPP2-UE

The 3GPP2-VCC AS MUST support the IMS VoIP call origination with VCC AS anchoring procedures, when the 3GPP2-UE is in the PacketCable domain, as defined in [X.P0042-001] and the call origination in the MMD subsystem role specified in [X.P0042-002]. This entails reception and processing of an associated SIP INVITE request due to originating filter criteria.

The 3GPP2-VCC AS MUST support CS voice call originations with VCC AS anchoring procedures, when the 3GPP2-UE is in the CS domain, as defined in [X.P0042-001] and the call origination in the CS domain role specified in [X.P0042-002]. This entails the following:

- Reception and processing of an associated WIN OriginationRequest (ORREQ) message (upon the detection of an originating trigger at the MSC). In this case, the WIN ORREQ message does not contain the VDN, as discussed in Section 7.4.2.
- Reception and processing of an associated SIP INVITE request (directed to the IMRN, as assigned by the 3GPP2-VCC AS during the above processing).

If the 3GPP2-VCC AS supports media optimization, then the 3GPP2-VCC AS SHOULD be able to allocate IMRNs (for CS voice call originations) in a location-specific manner (e.g., taking into account the identity / location of the MSC that is currently serving the 3GPP2-UE).

[X.P0042-001] includes the reception and processing of an extraneous SIP INVITE request from the S-CSCF to the 3GPP2-VCC AS. If the corresponding iFC (as discussed in Section 7.4.2) is established in a manner that avoids the sending of this SIP INVITE request, then the 3GPP2-VCC AS is not required to receive and process this message.

As noted in Section 7.4.1, the 3GPP2-VCC AS is not required to support the pre-WIN CS voice call origination scenario as defined in [X.P0042-001].

The corresponding end-to-end call flows are illustrated in Appendix I.3 and in Appendix I.4.

7.4.4.3 3GPP2-VCC AS Call Termination to 3GPP2-UE

[X.P0042-001] and [X.P0042-002] include scenarios where the 3GPP2-UE's telephone number is homed in either the CS or the IMS domain. The PacketCable network only supports the case where the 3GPP2-UE's telephone number is homed in the PacketCable domain. The 3GPP2-VCC AS is not required to support scenarios where the 3GPP2-UE's telephone number is homed in the CS domain, as discussed in [X.P0042-001].

The 3GPP2-VCC AS **MUST** support voice call delivery on IMS as defined in [X.P0042-001] and the call termination in the MMD subsystem role specified in [X.P0042-002] for 3GPP2-UE call terminations in the PacketCable domain. This entails reception and processing of an associated SIP INVITE request due to terminating filter criteria.

The 3GPP2-VCC AS **MUST** support voice call delivery on 1x CS as defined in [X.P0042-001] and the call termination in the MMD subsystem role specified in [X.P0042-002] for 3GPP2-UE call terminations in the CS domain. This entails reception and processing of an associated SIP INVITE request due to terminating filter criteria, the subsequent generation of an associated MAP LocationRequest (LOCREQ) message to the HLR, and processing of the associated response.

The corresponding end-to-end call flows are illustrated in Appendix I.5 (UE Termination Call Setup in PacketCable Domain) and in Appendix I.6 (UE Termination Call Setup in CS Domain).

7.4.4.4 3GPP2-VCC AS Domain Transfer from PacketCable domain to Circuit-Switched Cellular domain

The 3GPP2-VCC AS **MUST** support signaling flow for handoff: WLAN VoIP-to-1x Circuit-Switched Voice (trigger based) procedures defined in [X.P0042-001] and the roles for domain transfer of a call from the MMD subsystem to the CS domain specified in [X.P0042-002].

- This entails reception and processing of an associated WIN OriginationRequest (ORREQ) message (upon the detection of an originating trigger at the MSC). In this case, the WIN ORREQ message contains the VDN, as discussed in Section 7.4.2.
- This also entails reception and processing of an associated SIP INVITE request (directed to the IMRN, as assigned by the 3GPP2-VCC AS during the above processing).
- The 3GPP2-VCC AS, acting as a Back-to-Back User Agent (B2BUA), uses Third-Party Call Control (3PCC) procedures to accomplish the domain transfer.

A 3GPP2-VCC AS is not required to support the HRPD IMS to CS domain transfer procedures as described in [X.P0042-001].

A 3GPP2-VCC AS is not required to support the non-trigger-based IMS to CS domain transfer procedures as described in [X.P0042-001].

The corresponding end-to-end call flow is illustrated in Section I.8 (PacketCable to CS VCC Domain Transfer Procedure for 2 Party Call).

7.4.4.5 3GPP2-VCC AS Domain Transfer from Circuit-Switched Cellular domain to PacketCable domain

The 3GPP2-VCC AS **MUST** support the 1x CS to WLAN domain-transfer procedures, as defined in [X.P0042-001] and the roles for domain transfer of a call from the CS domain to the MMD subsystem specified in [X.P0042-002]. This entails reception and processing of a SIP INVITE request due to originating filter criteria. (In this case, the

corresponding SIP INVITE contains the VDI, as discussed in Section 7.4.2.) The 3GPP2-VCC AS, acting as a B2BUA, uses 3PCC procedures to accomplish the domain transfer.

The corresponding end-to-end call flow is illustrated in Section I.7.

7.4.4.6 3GPP2-VCC AS Support of Telephony Service Execution - Hybrid Model

Additional 3GPP2-VCC AS requirements for supporting telephony service execution (with the hybrid service execution model) are specified in Sections 7.6 and 7.7.

This specification supersedes any telephony or supplementary service specifications for the 3GPP2-VCC AS contained in [X.P0042-001] or [X.P0042-002]. For example, procedures related to call forwarding within the CS domain (as described in [X.P0042-001]) are not required, since the corresponding cellular call forwarding features are disabled for the PacketCable call forwarding service.

7.4.4.7 Accounting

The 3GPP2-VCC AS **MUST** generate offline accounting records over the Rf interface, as specified in [PKT ACCT]. These records are in addition to the normal accounting records that other PacketCable network elements are generating.

7.5 Telephony Supplementary Services

Supplementary services under consideration for the purpose of this specification are based upon the Residential SIP telephony (RST) Specification [RSTF]. Cellular Integration creates unique requirements related to interoperation with circuit-switched cellular networks because the signaling environment is no longer all SIP as expected by RST. To address the differences two execution models are defined herein and supplementary service modifications are defined relative to the definitions given in [RSTF].

7.5.1 Supplementary Service Execution Models

Supplementary Services are divided into two different service execution models, Hybrid Service Execution (HSE) and Centralized Service Execution (CSE). HSE defines a division of supplementary service execution between the PacketCable and CS domain. The HSE model allows for operating environments that do not support a reliable method of transferring mid-call feature control information from the CS to PacketCable network. The CSE model enables the control of all supplementary services from the PacketCable core via a reliable signaling method. The CSE model is out of scope for the present release of this document.

7.6 Hybrid Service Execution (HSE) Model

The HSE model divides the control of execution of telephony services between the PacketCable network and the CS domain. HSE generally places control of originating and terminating telephony services in the PacketCable network, and multiple leg call services such as call wait, call hold, and N-way calling in the local domain.

When using HSE, there are precautions, limitations and restrictions that the network operator needs to note. The following are those that have been identified:

- Service profiles for the subscriber are coordinated between the two domains. Not only will the set of features that the UE user may invoke be equivalent in both domains, but care needs to be taken to align the state of barring and forwarding features in each domain so as to not preclude domain transfer in either direction. Each feature section below specifies feature data requirements accordingly.

- Feature operation limitations on circuit cellular networks may force restrictions on the operation of the wireless RST client for the sake of a consistent user experience. Restrictions are specified in each feature section as needed.
- Peculiarities of network behavior may be seen by either the UE user or the other end point user in particular scenarios involving domain transfer of mid-call services. As an example, consider the PacketCable-to-3GPP2 CS domain transfer of a call on hold in which the first (oldest) call was active prior to the transfer and the second (younger) call was on hold and UE-terminated rather than UE-originated. In such a scenario, following domain transfer of the UE the other end point user may perceive that he or she is active on call when in fact the media is being held at the 3GPP2 (CDMA) MSC.

This section is largely informative since telephony feature interaction with VCC is often controlled by provisioning and network configuration. Most normative requirements are found in [RSTF] and cellular supplementary service specifications. A few normative requirements are also placed on the VCC UE or VCC AS in order to support feature consistency across PacketCable and circuit cellular networks.

7.6.1 Caller ID Delivery (CND and CNAMD)

The [RSTF] defines CND and CNAMD as AS-based termination features where the incoming caller's number and user name are provided to the terminating UE.

7.6.1.1 User Feature Activation and Deactivation

For both CND and CNAM, the [RSTF] indicates that these features may either be active or inactive according to subscription provisioning by the service operator. There is no VSC associated with the dynamic activation or deactivation of these features.

7.6.1.2 Feature Execution

While the UE is on CS Cellular, the UE would be receiving its Caller ID Delivery feature from the equivalent CS Cellular feature, i.e., CLIP [TS 22.081], [TS 23.081], [TS 24.081] and CNAP [TS 22.096], [TS 23.096], [TS 24.096] in 3GPP; and CNIP [S.R0006-0] and CNAP [S.R0006-0] in 3GPP2.

For a VCC UE that is provisioned with PacketCable CND/CNAMD feature, the iFC may cause the S-CSCF to route the initial INVITE destined to the VCC UE to go through the CND/CNAMD AS, before reaching the VCC AS. Note that if the Calling Name is provided by the CND/CNAMD AS in the terminating INVITE sent towards the UE on CS Cellular, the MGC/MG will propagate this calling name on ISUP trunks according to [RSTF]. If MF trunks are encountered in delivering the call to the UE on CS Cellular, the calling name is no longer propagated. In these cases, the calling name is retrieved by the receiving CS Cellular network according to existing CS Cellular specifications.

No changes are required to the RST CND/CNAMD AS.

This feature does not introduce any new constraint on Domain Transfer.

7.6.1.3 Feature Data

Caller ID Delivery Feature Data as defined in the [RSTF] are all applicable and no other feature data is specified for PacketCable Wireless and Cellular Integration.

7.6.1.4 Feature interactions

Feature interactions are defined in CS Cellular feature documents [TS 22.081], [TS 23.081], [TS 24.081], [TS 22.096], [TS 23.096], [TS 24.096], and [S.R0006-0].

7.6.1.5 3GPP and 3GPP2 Circuit Cellular Profile Recommendations

To allow seamless execution of Caller ID Delivery, the 3GPP cellular profile for CLIP [TS 22.081], [TS 23.081], [TS 24.081] and CNAP [TS 22.096], [TS 23.096], [TS 24.096] needs to match the PacketCable profile for CNID and CNAMD. Similar recommendation is to be followed with respect to the 3GPP2 cellular profile for CNIP [S.R0006-0] and CNAP [S.R0006-0].

7.6.2 Caller ID Per-Call Delivery

The [RSTF] Caller ID Per-Call Delivery feature provides a means for a UE to override its Permanent Presentation Status (PPS) with the value "public", which will have the effect of enabling its calling number and calling name presentation on a per call basis.

7.6.2.1 User Feature Activation and Deactivation

[RSTF] specifies a VSC provisioned in the UE for activating the feature. When the UE is on CS Cellular, and the user activates the VSC, the UE SHOULD translate that VSC to the appropriate action required by the VSC of the corresponding CS Cellular feature.

7.6.2.2 Feature Execution

While the UE is on CS Cellular, the UE would be using the equivalent CS Cellular feature, i.e.:

- Calling Line Identification Restriction (CLIR) [TS 22.081], [TS 23.081], and [TS 24.081] provisioned in temporary mode, and Calling Name Presentation (CNAP) [TS 22.096], [TS 23.096], and [TS 24.096] in the case of 3GPP.
- Calling Number Identification Restriction (CNIR) [S.R0006-0]. with subscription option "temporary mode" with default presentation set to "Presentation Restricted", and Calling Name Restriction (CNAR) [S.R0006-0] provisioned in "variable mode" with Network Stored Default of "Presentation Restricted", in the case of 3GPP2.

Domain Transfer is not limited while this feature is executed. However, if domain transfer has occurred after the feature has been activated, but before making the next call, the UE MUST re-activate the feature on the new domain prior to making the call in order for the feature to be active for that next call.

7.6.2.3 Feature Data

[RSTF] defines the following feature data:

- Feature availability status
- Confirmation Tone After vertical feature code
- Error Tone after vertical feature code failure

Out of these three feature data items, only the first one is relevant for dual-mode UEs. The other two refer to tones generated toward an analog phone connected to an E-MTA, for example.

7.6.2.4 Feature interactions

For UE operating on CS Cellular, the feature interactions are as per the corresponding CS Cellular features [TS 22.081], [TS 23.081], [TS 24.081], [TS 22.096], [TS 23.096], [TS 24.096], and [S.R0006-0].

7.6.2.5 3GPP and 3GPP2 Circuit Cellular Profile Recommendations

To allow seamless execution of this feature, the 3GPP cellular profile for CLIP [TS 22.081], [TS 23.081], [TS 24.081] and CNAP [TS 22.096], [TS 23.096], and [TS 24.096] needs to match the PacketCable profile for CND and CNAMD. Similar recommendation is to be followed with respect to the 3GPP2 cellular profile for CNIP [S.R0006-0] and CNAP [S.R0006-0].

7.6.3 Caller ID Per-Line Blocking

[RSTF] defines Caller ID Per-Line Blocking as a UE based originating feature where the caller's number and user name are simultaneously blocked from presentation to the terminating UE.

7.6.3.1 User Feature Activation and Deactivation

[RSTF] specifies that this feature is activated through provisioning. There is no VSC for this feature.

7.6.3.2 Feature Execution

While the UE is on CS Cellular, the UE will make use of the equivalent CS Cellular feature for carrying its caller ID number and name presentation restriction to the other user. In 3GPP, the corresponding feature is Calling Line Identity Restriction (CLIR) in permanent mode (see section 2 in [TS 22.081]) and Calling Name Presentation (CNAP) [TS 23.081]). In 3GPP2, the corresponding feature is Calling Number Identification Restriction (CNIR) [TS 24.081] and Calling Name Restriction (CNAR) [TS 24.081].

The feature does not introduce any new constraints on Domain Transfer.

7.6.3.3 Feature Data

While the UE is on CS cellular, feature data specific to the CS cellular feature need to be used.

7.6.3.4 Feature interactions

While the UE is on CS Cellular, the feature interaction specified in the appropriate CS Cellular feature specification (see [TS 22.081], [TS 23.081], and [TS 24.081]) will apply.

7.6.3.5 3GPP and 3GPP2 Circuit Cellular Profile Recommendations

To allow seamless execution of this feature, the 3GPP cellular profile for CLIP [TS 22.081], [TS 23.081], [TS 24.081] and CNAP [TS 22.096], [TS 23.096], and [TS 24.096] needs to match the PacketCable profile for Caller ID Per-Line Blocking. Similar recommendation is to be followed with respect to the 3GPP2 cellular profile for CNIP [S.R0006-0] and CNAP [S.R0006-0].

7.6.4 Caller ID Per-Call Blocking

[RSTF] Caller ID Per-Call Blocking feature provides a means for a UE to override its PPS with the value "anonymous", which will have the effect of blocking its calling number and its calling name for the next outbound call from the UE.

7.6.4.1 User Feature Activation and Deactivation

[RSTF] specifies a VSC provisioned in the UE for activating the feature. When the UE is on CS cellular, a user activating that VSC will cause the UE to translate that VSC to the appropriate action required by the corresponding CS cellular feature.

7.6.4.2 Feature Execution

While the UE is on CS cellular, the UE would be using the equivalent CS cellular feature, i.e.:

- Calling Line Identification Restriction (CLIR) [TS 22.081] provisioned in temporary mode, and Calling Name Presentation (CNAP) [TS 23.081] in the case of 3GPP;
- Calling Number Identification Restriction (CNIR) [TS 24.081] with subscription option "temporary mode" with default presentation set to "Presentation Allowed", and Calling Name Restriction (CNAR) [TS 24.081] provisioned in "variable mode" with Network Stored Default of "Presentation Allowed" in the case of 3GPP2.

Domain Transfer is not limited while this feature is executed. However, if domain transfer has occurred after the feature has been activated, but before making the next call, the UE MUST re-activate the feature on the new domain prior to making the call in order for the feature to be active for that next call.

7.6.4.3 Feature Data

[RSTF] defines the following feature data:

- Feature availability status
- Confirmation Tone After vertical feature code
- Error Tone after vertical feature code failure

Out of these three feature data items, only the first one is relevant for dual-mode UEs. The other two refer to tones generated toward an analog phone connected to an E-MTA, for example.

7.6.4.4 Feature interactions

Feature interactions are defined in corresponding CS cellular feature description, see [TS 22.081], [TS 23.081], and [TS 24.081].

7.6.4.5 3GPP and 3GPP2 Circuit Cellular profile Recommendations

To allow seamless execution of this feature, the 3GPP cellular profile for CLIP [TS 22.081], [TS 23.081], and [TS 24.081] and CNAP [TS 22.096], [TS 23.096], and [TS 24.096] needs to match the PacketCable profile for Caller ID Per-Line Blocking. Similar recommendation is to be followed with respect to the 3GPP2 cellular profile for CNIP [S.R0006-0] and CNAP [S.R0006-0].

7.6.5 Anonymous Call Rejection (ACR)

The [RSTF] defines ACR as an AS based termination feature where the incoming calls for which the identity of the originating user is or has been restricted are blocked.

7.6.5.1 User Feature Activation and Deactivation

[RSTF] uses a vertical service code (VSC) that the UE sends via an INVITE to the ACR AS. Normally the vertical service codes are star codes and not routable telephone numbers. The ACR AS then sets up a session that is used to complete the activation or deactivation function. For a VCC UE that is operating in the CS cellular network, the star codes may not be properly routed to the ACR AS. Thus for VCC subscribers, the star codes that are used for vertical services may be replaced by an alternate routable number that routes to the ACR AS.

Domain Transfer is not limited while executing the feature activation or deactivation function.

7.6.5.2 Feature Execution

For a VCC subscriber that is provisioned with the ACR feature, iFC may cause the S-CSCF to route initial INVITEs destined to the VCC UE through the ACR AS. These iFC need to be executed before the iFC for the VCC Application.

No changes are required to the RST ACR AS.

While a UE is on CS cellular, the ACR feature is executed in the PacketCable domain, as all calls are anchored within the PacketCable domain for VCC subscribers.

This feature does not add additional restrictions to Domain Transfer.

7.6.5.3 Feature Data

Feature data is defined in [RSTF].

7.6.5.4 Feature interactions

Feature interactions are defined in [RSTF].

7.6.5.5 3GPP and 3GPP2 Circuit Cellular Profile Recommendations

No equivalent 3GPP- or 3GPP2-defined service has been identified; therefore, there are no impacts to existing circuit cellular profiles.

7.6.6 Call Forwarding

The [RSTF] defines Call Forwarding as an AS based termination (as it is triggered by a call to the UE) feature where the call logic is applied to forward calls directed to the RST subscriber to an alternate "forward to" number.

7.6.6.1 User Feature Activation and Deactivation

Call Forwarding Variable (CFV) and Selective Call Forwarding (SCF) allow the user to activate and deactivate the features from the UE. The other call forwarding features are either network provisioned (CFDA and CFBL) or can be activated by any phone (RACF).

[RSTF] uses a vertical service code (VSC) that the UE sends via an INVITE to the Call Forwarding Application Server. Normally the vertical service codes are star codes and not routable telephone numbers. The Call Forwarding AS then sets up a session that is used to complete the activation or deactivation function. For a VCC UE that is operating in the cellular network, the star codes may not be properly routed to the Call Forwarding AS. Thus for VCC subscribers, the star codes that are used for vertical services may be replaced by an alternate routable number that routes to the Call Forwarding AS.

The Call Forwarding AS controlling the SCF activation and deactivation is unchanged. The key difference is the use of the routable number as described above. On activation or deactivation of SCF using either VSC, the VCC UE sets up a call via the VSC to the Call Forwarding AS controlled IVR system that plays announcements and receives DTMF tones in response. The VCC UE is capable of providing the same interaction in either the CS cellular or the PacketCable domain.

For CFV activation to a user provided number, the RST mechanism is to send an INVITE containing both a star code and the forward-to party number. There is no guarantee that the CS cellular network will support sending a star code plus forward-to party number as the called party number. Thus, CFV activation and deactivation will use a different mechanism. The cellular transport mechanism used to transfer feature data such as CFV activation, while

the UE is in the circuit cellular domain is for further study. The mechanism is to modify the RACF to include an option that eliminates the need for the user to enter the address/PIN combination.

On activation or deactivation of CFV, the VCC UE will send a call using the VSC that causes a call to be setup with the Call Forwarding AS providing the RACF function. This number is not the same as the normal RACF telephone number to avoid conflict with normal RACF functionality from the VCC UE (e.g., someone else uses the VCC UE to activate CFV for their number). If the INVITE received at the Call Forwarding AS includes the P-Asserted-Identity of the VCC UE (when it is in the CS cellular domain, it will be provided as a result of the VCC call-anchoring function), then RACF SHOULD use this provided P-Asserted-Identity to validate the user, eliminating the need for the IVR steps that obtain the user's address and PIN, and proceed with normal RACF procedures. The RACF IVR system MAY playback the VCC UE's telephone number for confirmation. Since RACF uses an IVR system, the VCC UE is capable of providing the same interaction in either the CS cellular or the PacketCable domain. RACF allows the user to perform any of the CFV activation and deactivation functions.

Since SCF and CFV activation and deactivation create active call sessions to a Call Forwarding AS, domain transfer may be requested while the session is active. Normal domain transfer procedures are allowed when either of these sessions is active.

7.6.6.2 Feature Execution

For a VCC subscriber that is provisioned with one of the RST Call Forwarding features, the iFC may cause the S-CSCF to route initial INVITES destined to the VCC UE to go through the Call Forwarding AS. These iFC need to be executed before the iFC for the VCC Application.

No changes are required for the RST Call Forwarding Application Server.

When the VCC UE is registered in PacketCable domain, it may be provisioned to subscribe to the Call Forwarding Application Server to receive SIP notification with the current activation state when calls are forwarded and when activation state changes. When the VCC UE is only attached to the circuit-switch domain, the VCC UE will not receive those notifications.

Domain Transfer is not limited while this feature is executed.

7.6.6.3 Feature Data

There is one modification to the RST Call Forwarding feature data defined in [RSTF]. The change is to replace the activation and deactivation codes with routable telephone numbers.

The Digit Map Actions table in [RSTF] does not apply to the VCC UE.

7.6.6.4 Feature interactions

Feature interactions are defined in [RSTF].

7.6.6.5 3GPP and 3GPP2 Circuit Cellular Profile Recommendations

Any call forwarding features offered by the cellular domain will not be assigned in the HLR profile for the VCC subscriber.

7.6.7 Outbound Call Blocking

[RSTF] defines Outbound Call Blocking (OCB) as an AS based origination feature where the calls are blocked based on different criteria, with PIN control available to the calling party to override blocking.

7.6.7.1 User Feature Activation and Deactivation

[RSTF] defines two methods for OCB feature activation and deactivation:

- User communication with a service provider operator
- Web Portal Access

When a UE is on CS cellular, the first method is accessible, while the second method may not be accessible for certain dual-mode handsets not supporting/subscribing to PS Cellular. However, as the majority of dual-mode handsets are expected to also support/subscribe to PS Cellular, Web Portal Access would be available for Outgoing Call Blocking feature activation/deactivation.

There is no change in feature activation from the RST spec for cellular integration.

RST feature Subscriber List Editing is used for feature provisioning, as described in Section 7.6.20 below.

7.6.7.2 Feature Execution

While a UE is on CS cellular, the Outbound Call Blocking feature is executed in the PacketCable domain, as all calls are anchored within the PacketCable domain for VCC subscribers.

Domain Transfer is not limited while this feature is executed.

7.6.7.3 Feature Data

OCB feature data is defined in [RSTF].

7.6.7.4 Feature Interactions

Feature interactions are defined in [RSTF].

7.6.7.5 3GPP and 3GPP2 Circuit Cellular Profile Recommendations

CS cellular domain Outgoing Call Blocking is recommended to be disabled.

7.6.8 Collect Call Blocking

[RSTF] defines Collect Call Blocking as feature hosted outside of the PacketCable network where incoming collect calls are blocked based on data present within the Line Identification (LIDB) database. There are neither impacts to, nor requirements on, the PacketCable network to support this service.

7.6.9 Solicitor Blocking

The [RSTF] defines Solicitor Blocking (also known as Privacy Screening) as the ability of a subscriber to establish via IVR interaction a list of numbers from which call termination attempts are allowed (a white list); call attempts from identities not explicitly listed are subject to blocking or screening.

7.6.9.1 User Feature Activation and Deactivation

User activation or deactivation is not required.

7.6.9.2 Feature Execution

Feature execution is defined in [RSTF].

Domain Transfer is not limited while this feature is executed.

7.6.9.3 Feature Data

Feature data is defined in [RSTF].

7.6.9.4 Feature Interaction

Feature data is defined in [RSTF].

7.6.9.5 3GPP and 3GPP2 Circuit Cellular Profile Recommendations

No equivalent service is identified for 3GPP. However, for 3GPP2-UEs to allow seamless execution of this feature, the 3GPP2 cellular profile will not have Rejection of Undesired Annoying Calls (RUAC) [S.R0006-0] assigned.

7.6.10 Call Wait

Call waiting is executed in the local domain under the hybrid model for telephony service execution, although all calls are still anchored in the PacketCable domain. Therefore, call waiting is executed per 3GPP and 3GPP2 specifications while the UE is in the CS domain and per the RST specifications while the UE is in the PacketCable domain. Note that RST Call Waiting is a client based feature.

7.6.10.1 User Feature Activation and Deactivation

Call waiting user feature activation and deactivation is executed per [RSTF] when the UE is in the PacketCable domain.

Call waiting user feature activation and deactivation is executed per [TS 23.083] and [TS 24.083] when the 3GPP-UE is in the 3GPP circuit-switched domain.

Call waiting user feature activation and deactivation is executed per [S.R0006-0] when the 3GPP2-UE is in the 3GPP2 circuit-switched domain.

7.6.10.2 Feature Execution

Call waiting is executed per [RSTF] when the UE is in the PacketCable domain.

Call waiting is executed per [TS 23.083] and [TS 24.083] when the UE is in the 3GPP circuit domain.

Call waiting is executed per [S.R0006-0] Wireless Features Description: Call Waiting when the UE is in the 3GPP2 circuit domain.

Domain Transfer for this feature is specified in Section 7.7.

7.6.10.3 Feature Data

Call waiting feature data is defined in [RSTF].

7.6.10.4 Feature interaction

Feature interactions with call waiting are defined per [RSTF] when the UE is in the PacketCable domain.

Feature interactions with call waiting are defined per [TS 23.083] and [TS 24.083] when the UE is in the 3GPP circuit domain.

Feature interactions with call waiting are defined per [S.R0006-0] when the UE is in the 3GPP2 circuit domain.

7.6.10.5 3GPP and 3GPP2 Circuit Cellular Profile Recommendations

To allow seamless execution of this feature, the 3GPP cellular profile for Call Waiting [TS 23.083] and [TS 24.083] needs to match the PacketCable profile for Call Waiting. Similar recommendation is to be followed with respect to the 3GPP2 cellular profile for Call Waiting [S.R0006-0].

7.6.11 Call Hold

The Call Hold capability is not defined a stand-alone feature for 3GPP2 CS cellular, although an integrated call hold capability is used in conjunction with several 3GPP2 circuit cellular services (Call Waiting, Three-Way Calling, Conference Calling and Call Transfer, as specified in [S.R0006-0]). See Sections 7.6.11, 7.6.12, and 7.6.13 for descriptions of these other features. Therefore, a separate Call Hold feature is not defined for 3GPP2-UEs via the Hybrid Service Execution Model. A standalone Call Hold feature is only defined for 3GPP-UEs via the Hybrid Service Execution Model. As noted, the Call Hold capability is combined with Call Waiting, Conference Calling and Call Transfer features for 3GPP2 UEs.

The [RSTF] defines Call Hold as a UE based Origination feature where a UE may put a currently active call on hold in order to:

- Initiate another call to a third party
- Accept an incoming call (notified through Call Waiting)
- Switch to a held call

The Call Hold feature is controlled by the local domain where the UE is currently served. Procedures for domain transfer are specified in Section 7.7.2.

7.6.11.1 User Feature Activation and Deactivation

[RSTF] uses a vertical service code (VSC) that the UE locally interpret to determine what action to take the next action, depending on the HOLD-ACTIVATE state in the UE. This VSC is not sent to the network.

In the case of a combo-device accessing PacketCable network, another type of user interface may be provided by the UE instead of the VSC.

7.6.11.2 Feature Execution

Call Hold is a local domain feature that is executed in the domain serving the user.

Feature execution is as per [RSTF] when the 3GPP-UE is in the PacketCable domain.

Feature execution is as per [TS 23.083] and [TS 24.083] when the UE is in the 3GPP circuit switched domain.

VCC AS and UE requirements for domain transfer while a 3GPP-UE has a call held and an active call are specified in Section 7.7.2.

7.6.11.3 Feature Data

No other feature data than what is already specified in [RSTF] and appropriate Call Hold feature specifications associated with 3GPP CS Cellular is required.

7.6.11.4 Feature Interactions

Feature interactions are as per [RSTF] when the UE is in the PacketCable domain.

7.6.11.5 3GPP Circuit Cellular Profile Recommendations

To allow seamless execution of the feature, the cellular profile needs to match the RST profile for the Call Hold features (i.e., if the feature is assigned in RST, it is authorized in cellular).

For 3GPP-UE, the 3GPP circuit profile for Call Hold per [TS 23.083] and [TS 24.083] need to be supported and authorized.

7.6.12 Call Transfer

The [RSTF] defines Call Transfer as an AS based multi-party (as it is triggered during a call by the UE) feature where the call logic is applied to transfer a call in progress at the RST subscriber to an alternate "transfer to" number.

7.6.12.1 User Feature Activation and Deactivation

There are no user capabilities to activate or deactivate the call transfer feature. Since Call Transfer is a local domain feature, the VCC UE needs to be provisioned with the call transfer service in both the CS cellular and PacketCable domains to allow seamless execution of the feature.

7.6.12.2 Feature Execution

The Call Transfer feature is a local domain feature. It will be executed in the current domain. The actual Call Transfer event is triggered when the UE releases the call sessions. At this point, the network will continue the transfer independent of any user actions and thus, Call Transfer is not impacted by a domain transfer. Any domain transfer impact occurs during the preparation stages.

In the process of preparing to execute a Call Transfer, there may be two calls active: (1) a call between the transferee and the transferor and (2) a call between the transferor and the transfer-to party. These two calls may be independent or they may be bridged into a temporary, three-way call. Neither the UE nor the network (MSC in cellular, Call Transfer AS in PacketCable) is aware that these calls are being setup to initiate a call transfer.

Prior to the Call Transfer, domain transfers will occur or be inhibited based on the status of the two calls. Once a domain transfer starts, the VCC UE will delay sending a Call Transfer request until the domain transfer completes. At that time, the VCC UE will execute a Call Transfer per the rules and procedures of the current domain (i.e., the domain after the domain transfer).

7.6.12.3 Feature Data

No changes are required to the RST feature data.

7.6.12.4 Feature interactions

Once a domain transfer is initiated, the VCC UE MUST delay the Call Transfer request until the domain transfer completes. In the PacketCable domain, the Call Transfer request is a REFER message from the VCC UE. In the CS cellular domain, the request is either a man machine interface (3GPP) or a disconnect (3GPP2) message from the VCC UE to the MSC.

An RST subscriber who is authorized to do Call Transfer needs to be authorized to do N-Way Calling specified in Section 7.6.13.

Within the CS cellular and PacketCable domains, existing feature interactions apply.

7.6.12.5 3GPP and 3GPP2 Circuit Cellular profile Recommendations

To allow seamless execution of the feature, the cellular profile needs to match the RST profile for both the Call Transfer and 3 way calling features (i.e., if the feature is assigned in RST, it is authorized in cellular).

7.6.13 N-Way Calling

[RSTF] provides for a 3-Way Calling (3WC) feature that is UE based. This service is entirely replaced by the N-Way Calling feature specified here for wireless subscribers irrespective of whether they have VCC capability. This feature allows a UE conformant to this specification to setup a call with multiple parties. The feature requires that the network provide a specialized Application Server to host N-way calls, this is referred to throughout as an N-Way AS. This specification uses the term 'N-Way Calling' to encompass both 3GPP's Multi-Party feature definition and 3GPP2's Three Way Calling (3WC) feature definition.

For Cellular Integration when support of 3GPP UEs is required, the PacketCable network MUST support the 3GPP Conferencing feature as specified in [TS 24.147] as modified by this specification.

For Cellular Integration when support of 3GPP2 UEs is required, the PacketCable network MUST support the 3GPP2 Conferencing feature as specified in [X.P0029] as modified by this specification. A 3GPP UE that supports the N-Way Calling feature MUST support the 3GPP Conferencing feature as specified in [TS 24.147] as modified by this specification when the UE is in the PacketCable domain. When the UE is in the CS domain, it MUST support the existing 3GPP Multi-Party feature defined in [TS 24.084].

A 3GPP2 UE that supports the N-Way Calling feature MUST support the 3GPP2 Conferencing feature as specified in [X.P0029] as modified by this specification when the UE is in the PacketCable domain. When the UE is in the CS domain, it MUST support the existing 3GPP2 3WC feature defined in [S.R0006-0].

7.6.13.1 User Feature Activation and Deactivation

There are no user capabilities to activate or deactivate the conferencing feature. Since N-Way Calling is a local domain feature, the UE needs to be provisioned in both the CS cellular and PacketCable domains to allow seamless execution of the feature.

7.6.13.2 Feature Execution

N-Way Calling is a local domain feature that is executed in the current domain. If compatibility is required between the Cellular and PacketCable domain implementations of the service, the PacketCable domain MUST limit the number of participants allowed to be the same as that in the circuit cellular domain.

For 3GPP UEs, feature execution is as per [TS 24.147] as modified by this specification when the UE is in the PacketCable domain; with the restriction that the N-Way Calling participant set be limited to the number of participants supported in the circuit cellular domain if compatibility is required as per the preceding clause. For

3GPP UEs, the cellular domain total number of participants is restricted to six (controlling party plus five invited participants) as defined in [TS 22.084].

Feature execution is as per [TS 24.084] when the UE is in the 3GPP circuit domain.

For 3GPP2 UEs, feature execution is as per [X.P0029] as modified by this specification when the UE is in the PacketCable domain; with the restriction that the N-Way Calling participant set be limited to the number of participants supported in the circuit cellular domain if compatibility is required as per the preceding clause. For 3GPP2 UEs the cellular domain total number of participants is restricted to three (controlling party plus two invited participants) as defined in [S.R0006-0].

Feature execution is as per [S.R0006-0] when the UE is in the 3GPP2 circuit domain.

7.6.13.3 N-Way Call Creation

In order to be able to create an N-Way call when in the PacketCable domain, a UE MUST be provisioned with an 'N-Way Bridge Factory URI'. When the UE that is in the PacketCable network wishes to create an N-Way call, the UE MUST send an INVITE to the network with a Request-URI populated with the provisioned 'N-Way Bridge Factory URI'. The 200 OK final response to this INVITE contains in the Contact header the 'N-Way Bridge URI' that the UE will use when inviting other parties to the N-Way call. This Contact header will also contain the 'isfocus' tag.

An N-Way AS that receives an initial INVITE containing an 'N-Way Bridge Factory URI' as the Request-URI MUST verify that the subscriber is authorized for N-Way call creation. On successful authorization of the request, the N-Way AS MUST allocate an 'N-Way Bridge URI' that represents the particular instance of an N-Way session that is being created. By means outside of the scope of this specification, the N-Way AS will allocate resources to host the N-Way call. On successful resource allocation, the N-Way AS MUST reply to the INVITE with a 200 OK final response. The N-Way AS MUST populate the Contact header of this 200 OK with the allocated 'N-Way Bridge URI' and the 'isfocus' tag.

7.6.13.4 Inviting Participants to the N-Way Call

A UE that has created an N-Way call in accordance with the requirements in this specification can add participants to the N-Way call. The inviting of a participant to an N-Way call can be done using a number of standard SIP mechanisms; these include (but are not limited to): issuance of an out-of-dialog REFER, creation of a dialog with the participant then issuing a REFER, issuing a REFER to the focus. In all cases, the N-Way call creating UE MUST provide the 'N-Way Bridge URI' that was generated as part of N-Way call creation to the participant.

7.6.13.5 Domain Transfer Considerations

Please see Section 7.7.3 for details.

7.6.13.6 Feature Data

The following data is required to support conferencing:

Table 7 - Feature Data for N-way Conferencing

Data	Type	Persistence	Scope	Stored by	Written by	Read by	PACM Requirement
N-Way Bridge Factory URI	String	Non-Volatile	Per public user ID	XDS	XDS	UE	Mandatory

The following call flow illustrates how a participant can be invited into an N-Way call by issuing a REFER to the N-Way AS:

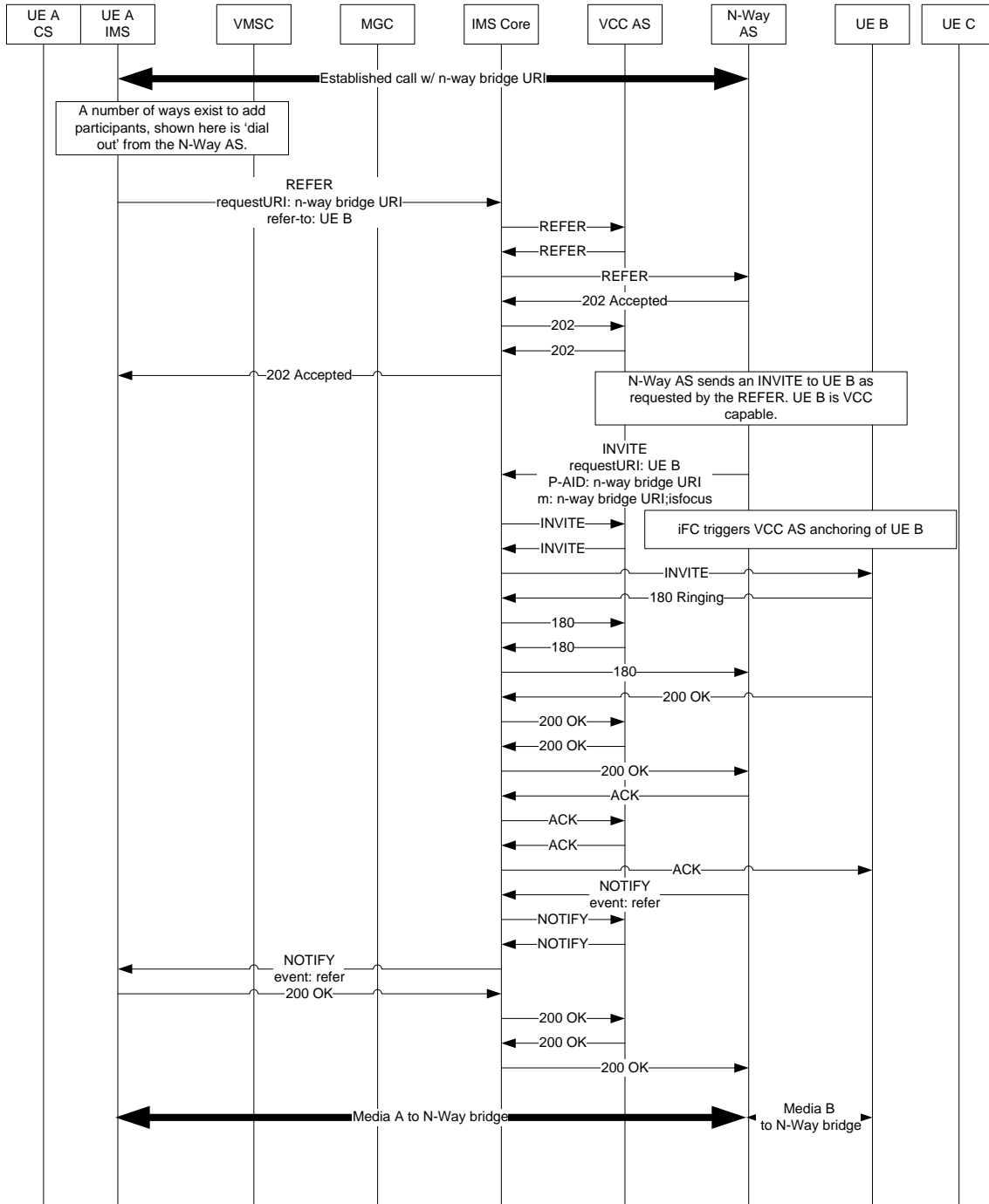

Figure 9 - Inviting an N-way Conference Participant with REFER to N-way AS

The following call flow illustrates how a participant can be invited into an N-Way call by issuing a REFER to the invited participant:

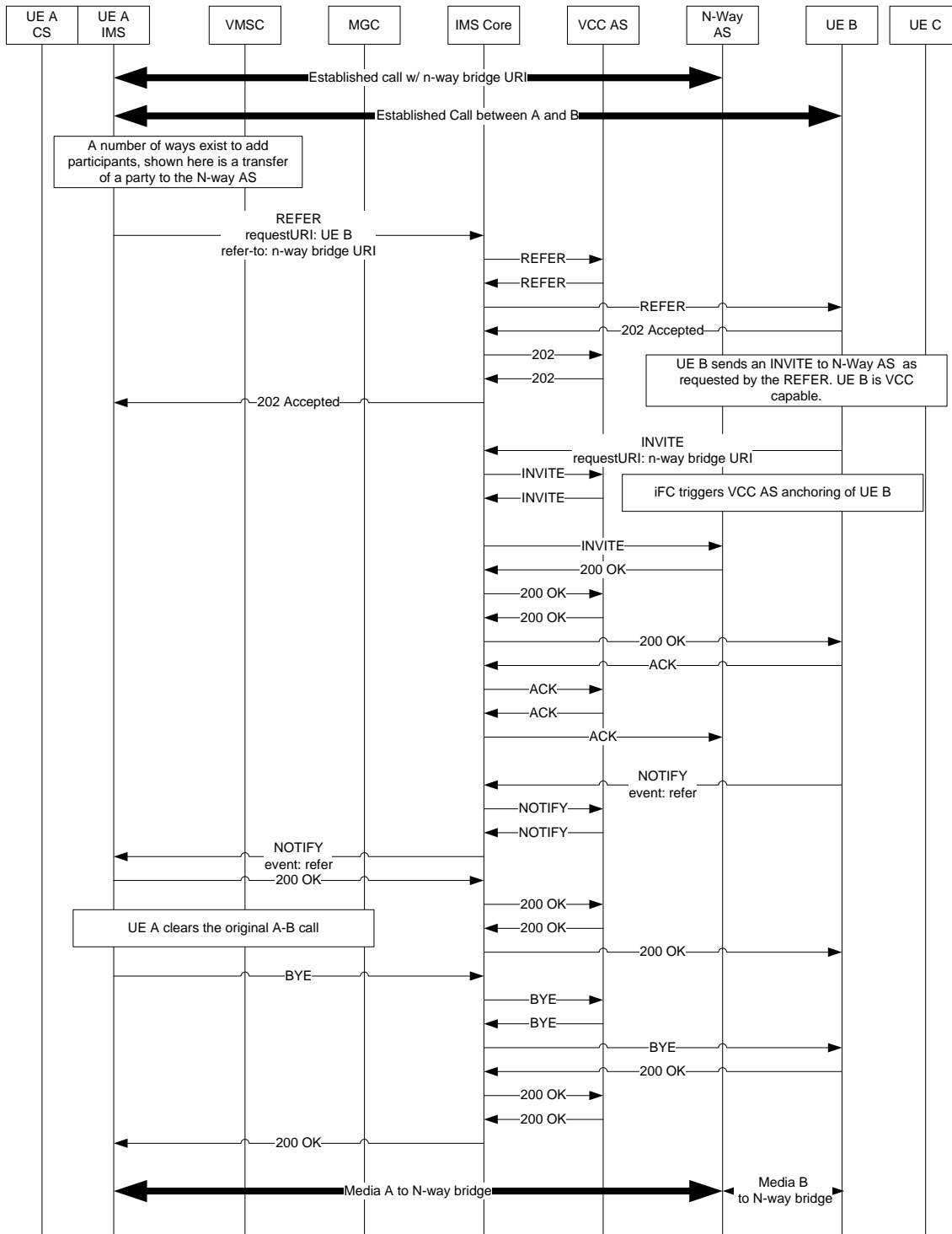

Figure 10 - Inviting an N-way Conference Participant with REFER to Participant

7.6.14 Do Not Disturb

The [RSTF] defines Do-Not-Disturb (DND) as an AS-based termination feature. The DND AS determines whether or not any incoming call to a UE will alert the user.

7.6.14.1 User Feature Activation and Deactivation

[RSTF] uses a vertical service code (VSC) that the UE sends via an INVITE to the DND AS. For a VCC UE that is operating in the cellular network, the star codes may not be properly routed to the DND AS. Thus for VCC subscribers, the star codes that are used for vertical services may be replaced by an alternate routable number that routes to the DND AS.

The DND AS controlling the DND activation and deactivation follows the general requirements in [RSTF]. The key difference is the use of the routable number as described above.

On activation or deactivation of DND using a corresponding VSC, the VCC UE sets up a call via the VSC to the DND AS controlled IVR system that plays announcements and receives DTMF tones in response. The VCC UE is capable of providing the same interaction in either the CS cellular or the PacketCable domain.

Since DND activation and deactivation creates an active call session to the DND AS, domain transfer may be requested while the session is active. Normal domain transfer procedure is allowed in this case.

7.6.14.2 Feature Execution

For a VCC subscriber that is provisioned with the DND RST feature, the iFC may cause the S-CSCF to route initial INVITES destined to the VCC UE to the DND AS. Such iFC MUST be executed before the iFC for the VCC AS.

No change is required for the RST DND AS.

When the VCC UE is registered in PacketCable domain, it MAY be provisioned to subscribe to the UA-Profile event package, so that it can receive SIP notifications with the DND activation state change, as specified in [RSTF] and [RST PACM]. When the VCC UE is only attached to the Circuit Switch domain, the VCC UE will not receive those notifications.

Domain Transfer is not limited while this feature is executed.

7.6.14.3 Feature Data

The same set of DND data defined in [RSTF] applies to the DND for the VCC UE.

7.6.14.4 Feature interactions

Feature interactions with DND are defined in [RSTF].

7.6.14.5 3GPP and 3GPP2 Circuit Cellular profile Recommendations

The DND feature offered by the cellular domain MUST NOT be assigned in the HLR profile for the VCC subscriber.

7.6.15 Subscriber Programmable PIN (SPP)

[RSTF] defines Subscriber Programmable PIN (SPP) as an Application Server based feature that enables the subscriber to manage PIN codes for their service(s) which require the use of a PIN as part of their operation. SPP is not assigned as a discrete service; rather it is enabled when a service that requires the use of a PIN is assigned.

7.6.15.1 User Feature Activation and Deactivation

[RSTF] uses a vertical service code (VSC) that the UE sends via an INVITE to the SPP AS. For a VCC UE that is operating in the cellular network, the codes may not be properly routed to the SPP AS. Thus for VCC subscribers, the codes that are used for vertical services may be replaced by an alternate routable number that routes to the SPP AS irrespective of the access technology.

The SPP AS controlling the SPP PIN management follows the general requirements in [RSTF]. The key difference is the use of the routable number as described above.

Since SPP PIN management creates an active call session to the SPP AS, domain transfer may be requested while the session is active. Normal domain transfer procedure is allowed in this case.

7.6.15.2 Feature Execution

The [RSTF] has no normative requirements on the behavior or actions applied by the SPP AS outside of informative details on typically expected behavior. The service may simply be viewed as a basic call (with a specialized access code) to an IVR or similar system that via DTMF or other mechanisms allows PIN management to take place. As such there are no additional requirements on this service brought by this specification.

7.6.15.3 Feature Data

No changes to the feature data defined in [RSTF].

7.6.15.4 Feature Interactions

Feature interactions are defined in [RSTF].

7.6.15.5 3GPP and 3GPP2 Circuit Cellular Profile Recommendations

No 3GPP and 3GPP2 circuit cellular profile data is needed.

7.6.16 Distinctive Alerting

Distinctive alerting is considered a client-based feature for the wireless dual-mode device while on both CS and PacketCable domains. No distinctive alerting requirements are placed on the wireless dual-mode device.

7.6.17 Message Waiting Indicator

[RSTF] defines Message Waiting Indicator (MWI) as an AS-based termination feature. The MWI AS notifies the user about the message status changes.

7.6.17.1 User Feature Activation and Deactivation

The MWI feature is activated or deactivated for a VCC UE via the cable service provider's provisioning process, as described in [RSTF]. The dynamic activation or deactivation is out of scope for this specification.

7.6.17.2 Feature Execution

The conditions for the triggering of MWI by the MWI AS are described in [RSTF].

The report of MWI by the MWI AS is based on the SIP notification of the Message Summary and Message Waiting Indication Events, as described in [RSTF].

The VCC UE MUST SUBSCRIBE to the Message Summary and Message Waiting Indication Event package [IETF 3842] while in the PacketCable domain, following the general requirements in [RSTF]. The duration of the subscription SHOULD be reasonably long so that the subscription will not be timed out while the UE is in the CS domain.

The S-CSCF follows the iFCs provisioned for the VCC UE to proxy the MWI NOTIFY message from the MWI AS to the VCC AS.

When the VCC UE is in the PacketCable domain, the VCC AS MUST forward the MWI NOTIFY message from the MWI AS to the UE. When the VCC UE is in the CS domain, the VCC AS MUST convert this NOTIFY into a message format (such as SMS) appropriate for the reception by the UE in the CS domain and forward the converted message to the VCC UE.

The VCC UE's mechanism of rendering the received MWI message to the user is vendor-specific, and is thus outside of the scope for this specification.

Domain Transfer is not limited while this feature is executed.

7.6.17.3 Feature Data

The same set of data items as that in [RSTF] applies to the MWI for the VCC UE.

7.6.17.4 Feature interactions

Feature interactions are defined in [RSTF].

7.6.17.5 3GPP and 3GPP2 Circuit Cellular profile Recommendations

The MWI feature offered by the cellular domain MUST NOT be assigned in the HLR profile for the VCC subscriber.

If SMS is used to deliver MWI, the SMS MUST be assigned as part of the 3GPP or 3GPP2 circuit cellular subscription.

7.6.18 Speed dialing

Speed dialing is considered a client-based feature for the wireless dual-mode device for both CS and PacketCable domains. No speed dialing requirements are placed on the wireless dual-mode device.

7.6.19 Customer Originated Trace

The [RSTF] defines Customer Originated Trace (COT) as an AS based origination (as it is triggered by a call from the UE) feature where the call data is captured by an AS or the UE (dependent on calling party privacy) and logged if a defined trace access code be dialed.

7.6.19.1 User Feature Activation and Deactivation

[RSTF] defines the following method for COT feature activation:

- Following reception of a malicious call, the subscriber dials a defined VSC (typically "*57").
- This call, via iFC triggers, is routed to a COT AS which verifies the intent to activate COT (IVR interaction). If COT is activated, the data that is logged is either as previously captured by the AS (if the calling part had caller id blocking) or provided in a P-DCS-TRACE_PARTY-ID header from the UE.

The activation of COT is achieved by the placing of a 'call' that is routed to the COT AS using iFC triggers on the Request-URI. Therefore, the activation procedure for COT with Wireless Inter-working is as follows:

- Following reception of a malicious call, the subscriber via the dual-mode device indicates that this is a malicious call through a user interface, the definition of which is beyond the scope of this specification.
- Provisioned on the device via PACM is an access number for COT which is then used to place a call either via a SIP INVITE (if the UE is in the PacketCable domain) or via a SETUP/appropriate TDM signaling (if the UE is in the CS domain).
- This call is routed to the PacketCable network irrespective of access media as all calls are anchored for VCC subscribers.
- Via iFC triggers the call is routed to a COT AS which verifies the intent to activate COT (IVR interaction).
- If COT is activated, the data that is logged is as previously captured by the AS.

7.6.19.2 Feature Execution

While a UE is in the CS cellular domain, Customer Originated Trace is executed in the PacketCable domain, because anchoring of calls takes place in the PacketCable domain.

In a divergence from the definition in [RSTF], if the subscriber has COT in their service profile, then *all* calls presented to the subscriber will trigger via iFC to the COT AS in order to capture calling party data; thus removing the requirement for the UE to store and subsequently provide SIP dialog specific information which will not be available when roaming in CS cellular.

Domain Transfer is not limited while this feature is executed.

7.6.19.3 Feature Data

The defined Customer Originated Trace Feature Data as defined in the [RSTF] is modified as given below:

Table 8 - Customer Originated Trace Feature Data Modified by Wireless Inter-working

Data	Type	Persistence	Scope	Stored by	Written by	Read by	PACM Requirement
Feature Activation Status	Boolean	Non-volatile	Per public identity	AS, PACM, HSS	AS, UE	S-CSCF	None
P-Asserted Identity Header	ASCII string	Limited	Per session	AS	P-CSCF	AS	None
Feature Activation Code	E.164 number, or star code	Non-volatile	Per network	AS, PACM, HSS	PACM	PACM	None
Call History Time Period	Integer (seconds)	Non-volatile	Per network	AS	OSS	AS	None

7.6.19.4 Feature interactions

Feature data is defined in [RSTF].

7.6.19.5 3GPP and 3GPP2 Circuit Cellular profile Recommendations

No 3GPP or 3GPP2 circuit cellular profile data is needed.

7.6.20 Subscriber List Editing

[RSTF] defines Subscriber List Editing (SLE) as the set of procedures that is intended to allow subscribers to activate and deactivate features that use lists, obtain a feature status report, and create and modify lists of addresses. Each list is associated with a particular feature to identify those calls that are to be given special treatment.

7.6.20.1 User Feature Activation and Deactivation

There is no user activation or deactivation.

7.6.20.2 Feature Execution

SLE does not exist as an independent function or service in its own right but rather is a capability that is used by services that require list editing.

These services include (but are not limited to): Selective Call Forwarding (SCF), Distinctive Ringing/Call Waiting, Do Not Disturb (DND) and Solicitor Call Blocking (SCB).

As such, please consult the service specific details for any feature execution specifics.

7.6.20.3 Feature Data

No feature data is required.

7.6.20.4 Feature Interactions

No additional feature interactions.

7.6.20.5 3GPP and 3GPP2 Circuit Cellular profile Recommendations

No 3GPP or 3GPP2 circuit cellular profile data is needed.

7.6.21 Call History Features

7.6.21.1 Automatic Callback (replaced by Automatic Redial)

[RSTF] defines Automatic Callback as a UE-based origination (as it is triggered by a call from the UE) feature where the call logic is applied to call back the last party dialed. In cellular CS domain, there is a similar UE-based feature called Automatic Redial that is an option in some cell phones.

7.6.21.2 User Feature Activation and Deactivation

There is no user activation or deactivation. Support for the feature is provisioned.

7.6.21.3 Feature Execution

There are two aspects of the Automatic Callback feature that go beyond a simple re-dial. The first is to be notified by a busy subscriber when the called party goes on-hook (using SUBSCRIBE/NOTIFY). The second unique aspect is to call back an auto recall number when the number was anonymous (using an Application Server to save the

anonymous party information). Both of these capabilities rely on features in the PacketCable domain and cannot be maintained when a domain transfer occurs.

3GPP has defined a similar feature, Completion of Calls to Busy Subscriber, for GSM subscribers (although it is not typically offered). There is no similar feature that is currently defined in 3GPP2. All cell phones offer the ability to redial the last number called. In addition, some phones offer Automatic Redial that does periodic retries if a busy was received. When the call goes through, the phone notifies the user. With these capabilities in the phone, there is limited need to offer a network supported automatic callback type of service.

For VCC subscribers, the RST Automatic Callback feature will not be supported in either domain. VCC UE based automatic redial may be supported to provide a similar service. Since automatic redial is self contained in the VCC UE, domain Transfer is not limited while this feature is executed.

7.6.21.4 Feature Data

For VCC UE, the digit map table will not include an Automatic Callback Activation entry.

7.6.21.5 Feature interactions

There are no feature interactions specified here. The Automatic Redial feature is self contained in the VCC UE.

7.6.21.6 3GPP and 3GPP2 Circuit Cellular profile Recommendations

Any automatic callback type services will not be authorized in 3GPP or 3GPP2 cellular profiles.

7.6.22 Operator services

The current RST version of these services is not recommended for the dual-mode handset. These services are for further study for cellular integration.

7.7 Transfer of Mid-Call Services

This section describes how mid-call services are continued while performing a domain transfer from the CS domain to the PacketCable network or vice versa. Please note that although only 3GPP is referenced here, this approach also works for 3GPP2 VCC.

7.7.1 Call Wait

In this section, the term VCC UE is used to indicate either a 3GPP-UE or a 3GPP2-UE as per Section 7.8.

The Call Waiting service presents an additional incoming call to a subscriber, who already has one or multiple established calls. As long as the VCC UE is involved in active calls in the CS domain or in the PacketCable, it uses the capabilities of the respective domain in order to provide the Call Waiting supplementary service. This section defines the network and UE behavior for Call Waiting service that is executed while the VCC UE performs a domain transfer.

7.7.1.1 Domain Transfer of a Call Waiting: CS domain to PacketCable

Domain Transfer of a Call Waiting implies following requirements to VCC UE and VCC-AS:

- If the VCC UE receives a call waiting after it has initiated the domain transfer, it **MUST NOT** present this call waiting to the user.

- If the VCC AS has received a request for domain transfer from the VCC UE after it has presented the call waiting in the old domain, it MUST cancel this call setup and present the call waiting to the VCC UE again in the new domain after the answered call(s) have been successfully transferred.
- If the 3GPP2-UE does a domain transfer in the call waiting scenario, it MUST indicate the call status (active, hold) in the SDP part of the INVITE that transfers the oldest call. The indication in the SDP is as specified in [RSTF].
- The 3GPP2-UE MUST put the remaining call into its original state (active, hold) after domain transfer was initiated and completed by the VCC AS.
- If the 3GPP2-UE initiates domain transfer while all calls have been answered, and one is on hold, then the VCC AS MUST perform domain transfer of the oldest call, according to procedures specified in Section 7.4.
- If the 3GPP2-UE initiates domain transfer while more than one answered calls are established, the VCC AS MUST initiate the domain transfer for the second (newest) call once the oldest one has been transferred, and sending an INVITE constructed for domain transfer to the UE.
- If the 3GPP-UE Call Waiting has been answered before the domain transfer is initiated, and one of the call is on hold, the 3GPP-UE MUST follow the requirements for CS to PacketCable domain transfer of Call Hold, see Section 7.7.2.1, Domain Transfer of a Call on hold: CS to PacketCable domain.
- If the 3GPP-UE Call Waiting has been answered before the domain transfer is initiated, and one of the call is on hold, the VCC AS MUST follow the requirements for CS to PacketCable domain transfer of Call Hold, see Section 7.7.2.1, Domain Transfer of a Call on hold: CS to PacketCable domain.

In Appendix II, Figure 29 - Domain Transfer of Call Waiting: CS domain to PacketCable provides an informative flow for the domain transfer of call waiting. The transfer takes place in the direction from the CS domain towards the PacketCable.

7.7.1.2 Domain Transfer of a Call Waiting: PacketCable to CS domain

Domain Transfer of a Call Waiting implies the following requirements to VCC UE and VCC AS:

- If the VCC UE receives a call waiting in PacketCable domain, but after it has initiated the domain transfer, it MUST not present this call waiting to the user.
- If the VCC AS has received a request for domain transfer from the VCC UE after it has presented the call waiting in the PacketCable domain, it MUST cancel this call setup and present the call waiting to the VCC UE again in the new domain after the answered call(s) have been successfully transferred.

Further Domain Transfer requirements apply to the UE and the VCC AS as follows:

- The 3GPP2-UE MUST initiate the domain transfer in the CS domain for the oldest call first.
- If the 3GPP2- UE initiates domain transfer while a call is on hold, the VCC AS MUST execute domain transfer of the oldest call.
- VCC-AS MUST keep knowledge of the direction of the younger call, i.e., whether the call was originated or terminated to the VCC-UE.
- VCC-UE MUST keep knowledge of the direction of the younger call, i.e., whether the call was originated or terminated to the VCC-UE.

If domain transfer was initiated by the 3GPP2-UE (say A) that has its oldest call on hold (say A-B), and the second call active (say A-C), and the second call was VCC AS initiated, then the VCC AS MUST initiate the transfer of the C-call leg following the transfer of the B-call leg by initiating a new CS call leg to the 3GPP2-UE. Furthermore, the 3GPP2-UE MUST respond to the received FLASH message by sending another FLASH message, and that without user intervention. See Figure 31.

If domain transfer was initiated by the 3GPP2-UE (say A) that has its second call on hold (say A-C), and the oldest call active (say A-B), and the second call was VCC AS initiated, then the VCC AS MUST initiate the transfer of the C-call leg following the transfer of the B-call leg by initiating a new CS call leg to the 3GPP2-UE. Furthermore, the 3GPP2-UE MUST respond to the received FLASH message by sending two subsequent FLASH messages, the first one to place party B on hold and connect to party C, and the second one to flip the active and held parties (i.e., to put C on hold, and retrieve B). The 3GPP2 UE MUST send these two Flash messages without user intervention. See Figure 32.

Figure 30 - Domain Transfer for a Call waiting: PC to CS domain provides an informative flow for domain transfer of waiting voice calls. The transfer takes place in the direction from the PacketCable towards the CS domain.

7.7.2 Call Hold

The Call Hold service allows a subscriber to put an answered call "on hold", i.e., the call is still established, but can't be used for communicating until it is resumed. When the VCC UE initiates a domain transfer, all answered calls need to be transferred, whether on hold or not.

The general principle that applies to this scenario lets the 3GPP-UE initiate the domain transfer for the oldest call and either the VCC AS or the 3GPP-UE to transfer the other call depending upon which entity originated the call.

7.7.2.1 Domain Transfer of a Call on hold: CS to PacketCable domain

Domain Transfer of a Call on hold from CS to PacketCable implies following requirements to 3GPP-UE and VCC AS.

- If the 3GPP-UE does a domain transfer in the call hold scenario, it MUST indicate the call status (active, hold) in the SDP part of the INVITE that transfers the oldest call. The indication in the SDP is as specified in [RSTF].
- The 3GPP-UE MUST put the remaining call into its original state (active, hold) after domain transfer was initiated and completed by the VCC AS.
- If the 3GPP-UE initiates domain transfer while all calls have been answered, and one is on hold, then the VCC AS MUST initiate domain transfer of the oldest call, according to procedures specified in Section 7.3
- If the 3GPP-UE initiates domain transfer while more than one answered calls are established, the VCC AS MUST initiate the domain transfer for the second (newest) call once the oldest one has been transferred, according to procedures specified in Section 7.3.

See Appendix II for informative flows.

7.7.2.2 Domain Transfer of a call on hold: PacketCable to CS domain

Domain Transfer of a Call on hold from PacketCable to CS implies following requirements to VCC UE and VCC AS.

- The 3GPP-UE MUST initiate the domain transfer in the CS domain for the active call.

- If the 3GPP-UE initiates domain transfer while a call is on hold, the VCC AS MUST execute domain transfer of the oldest call.
- VCC-AS MUST keep knowledge of the direction of the younger call, i.e., whether the call was originated or terminated to the 3GPP-UE.
- 3GPP-UE MUST keep knowledge of the direction of the younger call, i.e., whether the call was originated or terminated to the 3GPP-UE.
- If domain transfer was initiated by the 3GPP-UE (say A) that has its oldest call on hold (say A-B), and the second call active (say A-C), and the second call was 3GPP-UE initiated, then the 3GPP-UE MUST send a Hold message with the A-B Transaction Identifier following the domain transfer initiation, in order for the VMSC to put B on hold. Then the 3GPP-UE MUST send a Setup message including the C party DN. The 3GPP-UE MUST send the Hold and Setup messages without user intervention. See Figure 2.
- If domain transfer was initiated by the 3GPP-UE (say A), and the second call (say A-C) was VCC AS initiated, then the VCC AS MUST initiate the transfer of the C call leg following the transfer of the B call leg by initiating a new CS call leg to the 3GPP-UE. Furthermore, the 3GPP-UE MUST respond to the received Setup message for C by sending a Hold message with the A-B Transaction Identifier. The 3GPP-UE MUST then send a Connect message with C. The 3GPP-UE MUST send the Hold and Connect messages without user intervention. See Figure 23 and Figure 26.
- If domain transfer was initiated by the 3GPP-UE (say A) that has its second call on hold (say A-C), and the oldest call active (say A-B), and the second call (say A-C) was VCC AS initiated, then the 3GPP-UE MUST reconnect to B following the Connect message to C. This is done by the 3GPP-UE sending a Hold message including the transaction identifier A-C, and subsequently sending a Retrieve message including the transaction identifier A-B. The 3GPP-UE MUST send these Hold and Retrieve messages without user intervention. See Figure 26.
- If domain transfer was initiated by the 3GPP-UE (say A) that have its newest call on hold (say A-C), and the newest call was VCC AS initiated, then upon receiving the first Remote Hold indication for UE B following domain transfer initiation, the VCC AS MAY not forward it to the far end UE B. Furthermore, upon receiving the first Remote Hold indication for UE C following domain transfer initiation, the VCC AS MAY NOT forward it to the far end UE C. See Figure 26 and Figure 27.
- The VCC AS MUST NOT send to the far end Hold or Retrieve notifications received by the 3GPP-UE in the form of a re-INVITE, if it is targeted to a far end user for which the call leg is already on Hold (if it is an Hold indication), or already active (if it is a Retrieve indication). See Figure 22, Figure 23, Figure 26, and Figure 27 (remote retrieve towards B).
- To enable PacketCable to 3GPP CS domain transfer of Call Hold, the Call Waiting feature must be enabled and authorized in the 3GPP CS domain, in addition to the Call Hold feature. Figure 23 and Figure 26 illustrate the use of CS Call Waiting for such scenario.

See Appendix II for informative flows.

7.7.3 Domain Transfer Interaction with N-Way Calling

The N-Way Calling service allows a subscriber to initiate a network hosted N-Way call and subsequently invite participants to the dynamically created N-Way call. The call legs that are part of the N-Way call are either designated as a 'control leg' or a 'participant leg'. The 'control leg' is that call leg by which the N-Way call was established, a 'participant leg' is a call leg belonging to a subsequently invited participant.

Domain transfer of an N-Way call 'control leg' while a UE is part of an N-Way call is not required.

If domain transfer of an N-Way call control leg is supported, and if the PacketCable to 3GPP2 CS domain transfer was initiated by the 3GPP2-UE (say A) that has its oldest call on hold (say A-B), and the second call active (say A-C), and the second call was 3GPP2-UE initiated, then the 3GPP2-UE MUST send a FLASH message, optionally including the C-Party DN, following the domain transfer initiation, in order for the VMSC to put B on hold. If the sent FLASH message did not include the C-Party DN, then the 3GPP2-UE MUST send a second FLASH message including the C party DN. The 3GPP2-UE MUST send the (these) FLASH message (s) without user intervention. See Figure 33.

The VCC AS MUST support domain transfer of an N-Way call 'participant leg'. A 'participant leg' is treated as a regular two-party call and so the same procedures as for a basic stable call are followed.

Note: Domain transfer of the control leg is not required because of the non-deterministic error scenarios created if a domain transfer of a 'control leg' attempted while a REFER or other transaction intended to add other parties to the N-Way call is in progress. Transaction timeouts of either the REFER or subsequent NOTIFY requests will likely occur.

A call leg is identified as being an N-Way call 'control leg' at the VCC AS by the fact that the Request-URI of the SIP INVITE that creates the call leg is that of a well-known N-Way bridge factory. The mechanism whereby the VCC AS discovers the set of valid N-Way bridge factory URIs is outside of the scope of this specification. The 'participant leg' call legs will be addressed to dynamically created N-Way bridge URIs and not the well-known address of the N-Way bridge factory.

7.7.3.1 Domain Transfer of an N-Way Call 'Control Leg'

If domain transfer of a control leg from Packet Cable domain to CS domain is prohibited, the VCC AS MUST perform the following:

- Identify a call leg as an N-Way call 'control leg'
- Maintain the N-Way call leg designation as part of the call leg information in order to make the correct domain transfer decision
- Reject the Domain Transfer attempt

Figure 11 shows an illustrative call-flow of a rejected domain transfer request for a UE that is the owner of an N-Way call 'control leg'.

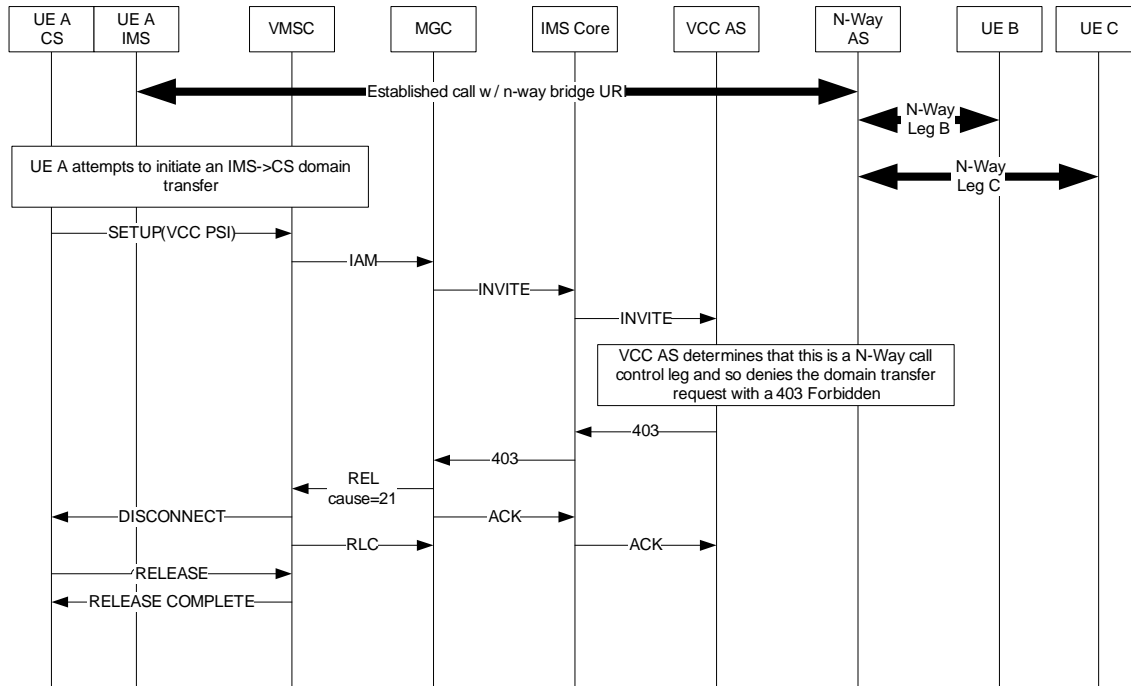

Figure 11 - Rejection of an N-way Conference Controller Domain Transfer Request

7.7.3.2 Domain Transfer of a N-Way Call ‘Participant Leg’

A domain transfer attempt of a UE that is not the control leg is treated by the VCC AS as a domain transfer request for a basic call and so follows the procedures in Sections 7.3 and 7.4.

7.8 Mobile Device Requirements

In this section, "PacketCable domain" access means an access to PacketCable 2.0 network through a wireless access technology such as WiFi [IEEE 802.11] connected to the DOCSIS network.

For interworking with 3GPP or 3GPP2 cellular network PacketCable domain, two different types of PacketCable 2.0 mobile devices are identified.

The 3GPP2 UE MUST:

- Support PacketCable domain access per [PKT 24.229] and [PKT 33.203].
- Support 3GPP cellular circuit-switched, plus additional procedures specified in this specification for 3GPP Voice Call Continuity, see Section 7.3.
- Support [PKT 24.229] with the constraints specified in this specification.
- Support simultaneous operation on a 3GPP circuit-switched cellular network and the PacketCable domain when executing the 3GPP VCC procedures specified in Section 7.3.

The 3GPP2 UE MUST:

- Support PacketCable domain access per [PKT 24.229] and [PKT 33.203].

- Support 3GPP2 cellular circuit switched and the specifications for 3GPP2 user equipment [C.S0005], plus additional procedures specified in this specification for 3GPP2 Voice Call Continuity, [X.P0042-002].
- Support [PKT 24.229] with the constraints specified in this specification.
- Support simultaneous operation on a 3GPP2 circuit-switched cellular network and the PacketCable domain when executing the 3GPP2 VCC procedures specified in Section 7.4.

7.9 Emergency Call Requirements

Emergency calls performed by PacketCable UE while roaming on other access networks such as 3GPP and 3GPP2 CS will trigger emergency procedures that are specific to these access networks (see [TS 24.008], [TS 29.002], and [TS 23.271] for 3GPP CS access, and [C.S0005] for 3GPP2 CS access).

7.9.1 General Requirements and Scope

If an emergency call has been originated in the PacketCable domain, domain transfer of this call to 3GPP or 3GPP2 CS is out of scope of this specification.

If an emergency call has been originated in the 3GPP or 3GPP2 CS domain, domain transfer of this call to the PacketCable domain is out of scope in this specification.

If an emergency call was successfully made, but was dropped, the PSAP needs to be able to call back the calling subscriber that has made the emergency call.

7.9.2 PacketCable UE - Emergency Call Origination

The following requirements are placed on the UE to support emergency calling on circuit cellular and PacketCable networks.

- PacketCable wireless UE MUST detect that a call origination is an emergency call.
- For emergency call origination on 3GPP CS network, 3GPP-UE MUST follow the procedures for emergency calls in [TS 24.008].
- For emergency call origination on 3GPP2 CS network, 3GPP2-UE MUST follow the procedures for emergency calls in [C.S0005].
- For emergency call origination on PacketCable, the UE MUST follow the procedures for emergency calls in [RSTF].

7.9.3 VCC AS

No new requirements are identified for supporting emergency services. If a PSAP calls back a UE, the incoming call is treated as a normal terminating call.

7.9.4 P-CSCF

No new requirements are identified for supporting emergency services for 3GPP-UE and 3GPP2-UE when accessing PacketCable domain.

7.9.5 E-CSCF

No new requirements are identified for supporting emergency services for 3GPP-UE and 3GPP2-UE when accessing PacketCable domain.

7.9.6 S-CSCF

No new requirements are identified for supporting emergency services for 3GPP-UE and 3GPP2-UE when accessing PacketCable domain.

7.10 Push-To-Talk over Cellular (PoC) applied to PacketCable

Push-to-Talk over Cellular (PoC) is an optional feature in both the PacketCable network and in the UE. The PacketCable PoC feature is based on the OMA PoC enabler as specified in [OMA-PoC-CP] and [OMA-PoC-UP].

When a network supports PoC, it **MUST** include one or more application servers that conform to the rules and procedures for application servers as specified in [PKT 24.229] and conform to the rules and procedures for Participating and Controlling PoC servers as specified in [OMA-PoC-CP] and [OMA-PoC-UP].

When a 3GPP-UE, or 3GPP2-UE supports PoC, it **MUST** conform to the rules and procedures for a PoC Client as specified in [OMA-PoC-CP] and [OMA-PoC-UP].

When a 3GPP-UE, or 3GPP2-UE supports PoC, it **MUST** support access to the PoC feature when the UE is operating in the PacketCable domain.

When a 3GPP-UE or 3GPP2-UE supports PoC, it **SHOULD** support access to the PoC feature when the UE is operating in the packet cellular domain. To support PoC when the UE is in the packet cellular domain, the 3GPP-UE or 3GPP2-UE **MUST** support IP access to the PacketCable domain. Prior to invoking the PoC service, the 3GPP-UE or 3GPP2-UE **MUST** register with the PacketCable domain and conform to standard UE rules and procedures as specified in [PKT 24.229].

Support of seamless domain transfer for the PoC feature when a 3GPP-UE or 3GPP2-UE moves between the packet cellular and PacketCable domains is outside the scope of this specification.

Note: While the PoC feature is defined for cellular integration, operators can also implement the PoC client on other PacketCable devices. When the PoC client is implemented on these devices, the 3GPP-UE or the 3GPP2-UE **SHOULD** be able to establish PoC sessions with these devices.

Appendix I Hybrid Control Model Flows (informative)

This section provides a consolidated set of 3GPP and 3GPP2 VCC flows. Media optimization techniques are included in the flows.

I.1 UE Registration in PacketCable Domain

Figure 12 illustrates the VCC signaling flow, associated with registration of the UE in the PacketCable domain. This flow is common to both 3GPP and 3GPP2 VCC.

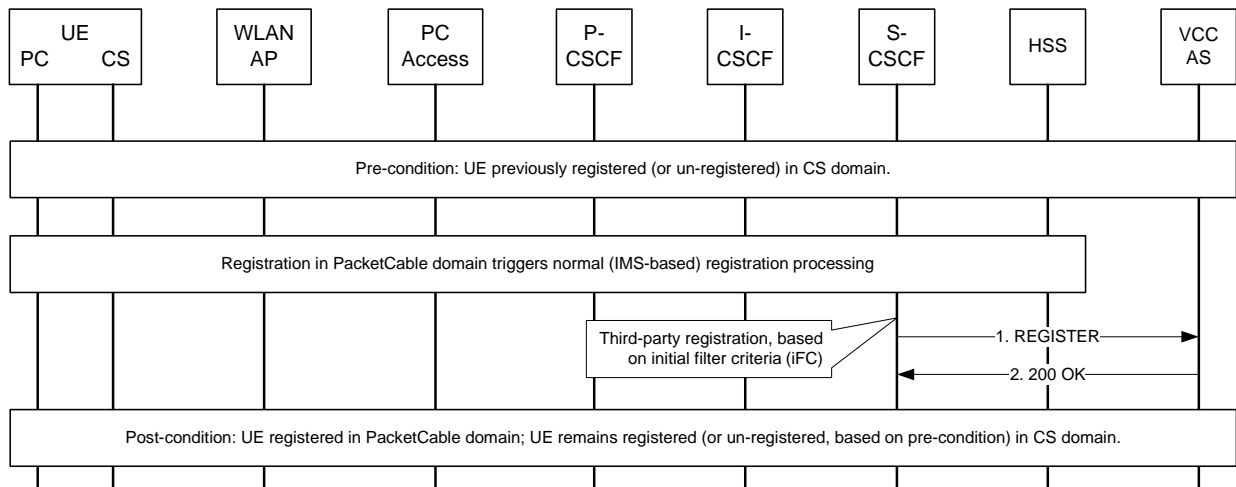

Figure 12 - UE Registration in PacketCable Domain

Figure 12 is based on basic PacketCable registration procedures. It is consistent with material contained in section 6.1.2 of [TS 23.206] and in section 5.1 of [X.P0042-001], yet only highlights the VCC-specific processing.

As indicated, when the UE registers in the PacketCable domain, normal PacketCable registration procedures are invoked. (Details of this processing can be found in [PKT 23.228]. In this case, the initial Filter Criteria (iFC) in the HSS Service Profile includes a Service Point Trigger (SPT) to designate that third-party registration procedures need to be invoked for the REGISTER method. Therefore (at step 1 in Figure 12), the S-CSCF sends a third-party REGISTER request to report the PacketCable registration to the designated AS (i.e., to the VCC AS in this case). The VCC AS returns a 200 OK response to the S-CSCF.

Upon successful completion of the above procedures, it is noted that the UE will be registered in the PacketCable domain. Based on the dual registration model, the UE's registration in the PacketCable domain does not impact the UE's registration in the CS domain (i.e., the HLR's location pointer is not impacted by these procedures).

I.2 UE Registration in CS Domain

This section describes UE registration in the CS domain. Separate flows are illustrated and described in the following subsections for the corresponding 3GPP2 and 3GPP procedures.

I.2.1 UE Registration in CS Domain - 3GPP2

Figure 13 illustrates the 3GPP2-VCC signaling flow, associated with registration of the 3GPP2-UE in the CS domain, based on 3GPP2 procedures.

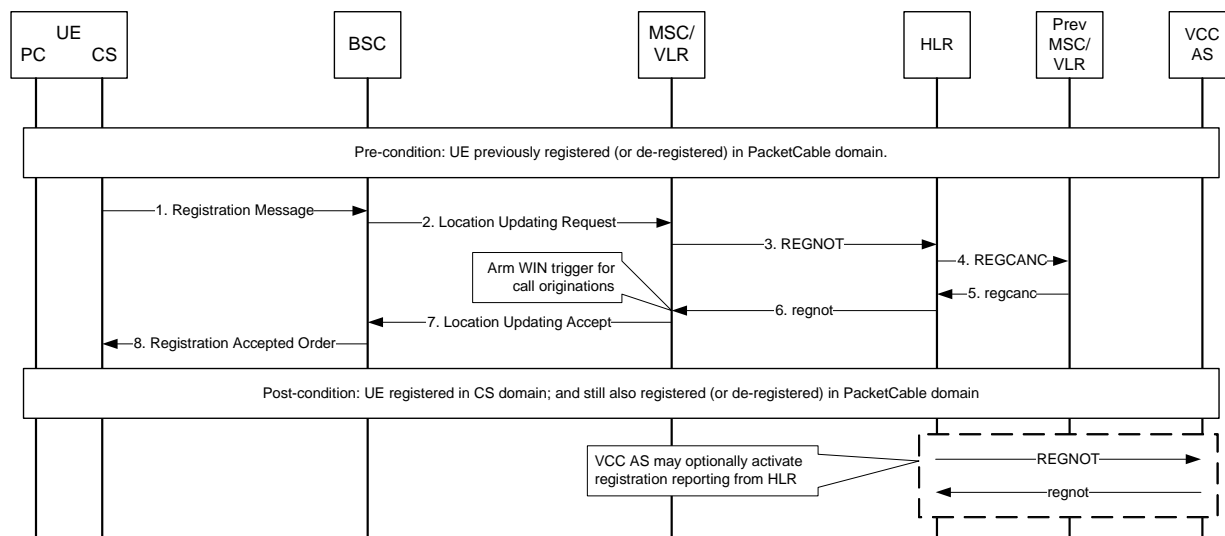

Figure 13 - UE Registration in CS Domain (3GPP2)

Figure 13 is based on material contained in section 5.2 of [X.P0042-001], and highlights the 3GPP2-VCC-specific processing related to WIN-trigger arming. It also suggests an optional extension to allow the 3GPP2-VCC AS to track the UE's CS registration state.

As illustrated in this figure, when the UE registers in the CS domain, normal ANSI-41 registration procedures are invoked. (Details of this processing can be found in Chapter 3 (section 5.1) of [N.S0005].) In steps 1 and 2, the UE sends a registration request that is used to notify the visited MSC/VLR. The MSC/VLR invokes normal ANSI-41 registration procedures at this time. It sends a MAP RegistrationNotification (REGNOT) to the UE's HLR (in step 3). The HLR performs its normal ANSI-41 processing, which entails cancellation of the UE's prior registration with the previous MSC/VLR via a MAP RegistrationCancellation (REGCANC) in steps 4 and 5. The HLR sends a regnot response back to the MSC/VLR (in step 6). The regnot response includes the UE's profile information, which (for 3GPP2-VCC) includes an indication that the appropriate originating WIN trigger is to be armed in the MSC/VLR. Normal signaling (steps 7 and 8) is used to report the successful completion of registration processing to the UE.

Note: If the home network (IMS-based) service execution model is to be applied, it is anticipated that the regnot response will indicate that many MSC-based features are to be disabled - with the corresponding PacketCable features instead offered via the user's home PacketCable network.

Upon successful completion of the above procedures, the UE will be registered in the CS domain, and the HLR's location pointer will indicate that the UE is registered at the MSC/VLR. However, it is noted that the UE's registration state in the PacketCable domain is not impacted by this processing.

Note: To allow the 3GPP2-VCC AS to track the UE's CS registration state, the 3GPP2-VCC AS could optionally activate Registration Reporting in the UE's HLR, as discussed in [X.S0009], Wireless Intelligent Network Support for Location Based Services. Using these procedures, the 3GPP2-VCC AS can be notified of changes to the UE's CS registration state - via MAP REGNOT and MSINACT messages.

I.2.2 UE Registration in CS Domain - 3GPP

Figure 14 illustrates the 3GPP-VCC signaling flow, associated with registration of the 3GPP-UE in the CS domain, based on 3GPP procedures.

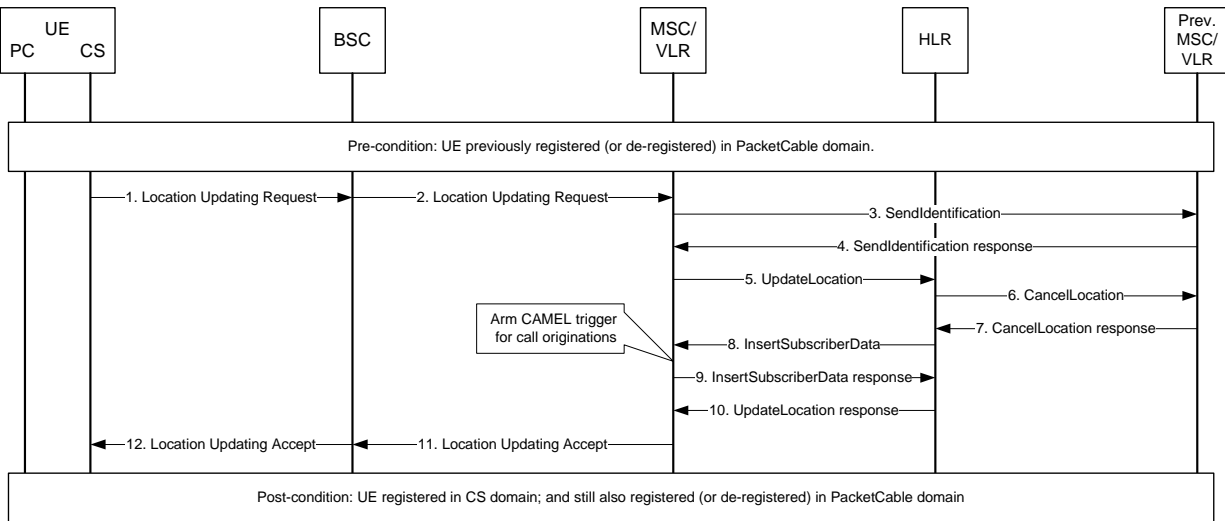

Figure 14 - UE Registration in CS Domain (3GPP)

Figure 14 is based on material contained in Section 6.1.1 of [TS 23.206], and highlights the 3GPP-VCC-specific processing related to CAMEL-trigger arming.

As illustrated in Figure 14, when the UE registers in the CS domain, normal 3GPP registration procedures are invoked. Further discussion of this processing can be found in Section 19.1.1.1 of [TS 29.002]. In steps 1 and 2, the UE sends a registration request that is used to notify the visited MSC/VLR. The MSC/VLR can retrieve user-related information from the previous MSC/VLR (via a MAP SendIdentification message in steps 3 and 4) and then sends a MAP UpdateLocation to the UE's HLR (in step 5). The HLR performs its normal processing. It cancels the UE's prior registration with the previous MSC/VLR (via a MAP CancelLocation message in steps 6 and 7). It sends the user's profile to the visited MSC/VLR via a MAP InsertSubscriberData message (which, for 3GPP-VCC, includes an indication that the appropriate originating CAMEL trigger is to be armed in the MSC/VLR) in steps 8 and 9. Finally, the HLR responds back to the MSC/VLR (in step 10). Normal signaling (steps 11 and 12) is used to report the successful completion of registration processing to the UE.

MAP messages, as referenced above, are described in [TS 29.002]. Other messages are described in [TS 24.008].

Upon successful completion of the above procedures, the UE will be registered in the CS domain, and the HLR's location pointer will indicate that the UE is registered at the MSC/VLR. However, it is noted that the UE's registration state in the PacketCable domain is not impacted by this processing.

I.3 UE Origination Call Setup in PacketCable Domain

This section illustrates the VCC signaling flow, associated with a call origination attempt by the UE in the PacketCable domain. In this case, it is assumed that the UE was previously registered in the PacketCable domain (with the S-CSCF depicted in this figure serving as the registrar). This flow is common to both 3GPP and 3GPP2 VCC.

The following figure is based on basic PacketCable origination procedures. Details of this processing can be found in [PKT 23.228]. It is noted that this figure is based on material contained in section 6.2.3 of [TS 23.206], and in section 6.1 of [X.P0042-001], but has been extended to include interactions with originating (e.g., Residential SIP Telephony [RSTF]) services offered via the PacketCable home network - via a separate PacketCable AS. This logic indicates that, for call originations, the VCC AS is invoked first, prior to any PacketCable services.

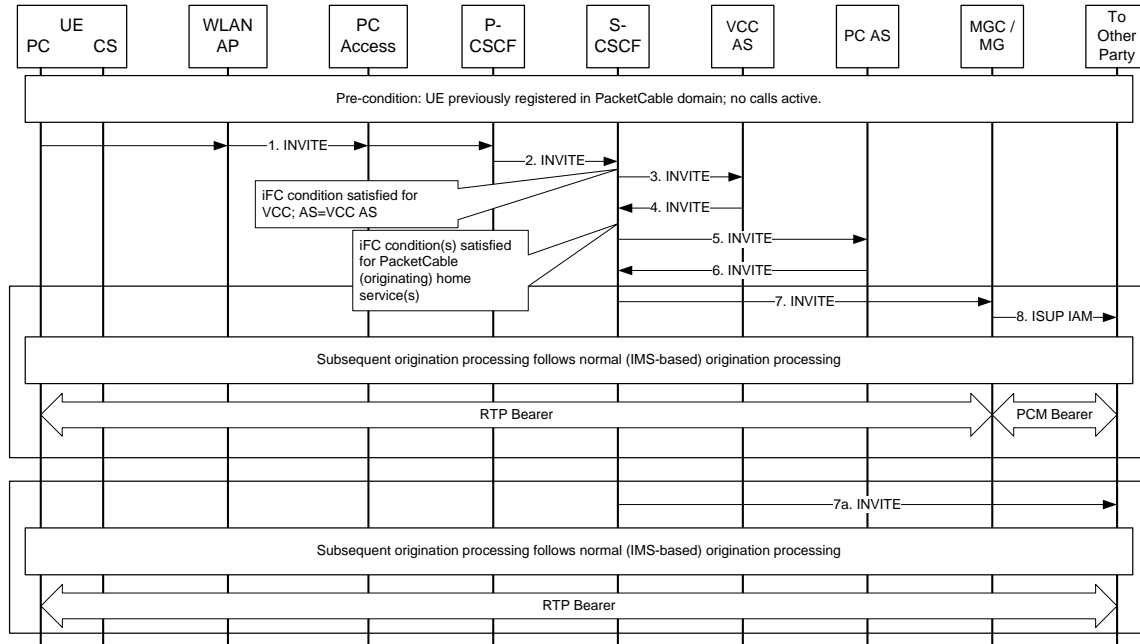

Figure 15 - UE Origination Call Setup in PacketCable Domain

When the UE originates a call in the PacketCable domain, normal PacketCable origination procedures are invoked. An initial INVITE is directed to the P-CSCF, and on to the UE's S-CSCF. In this case, multiple iFCs are stored in the S-CSCF (as established during prior PacketCable registration processing) associated with the originating INVITE method. Therefore (at step 3 in Figure 15), the S-CSCF (based on the priority associated with the corresponding iFC) first directs the INVITE to the VCC AS. The VCC AS retains information concerning the session and, acting as a Back-to-Back User Agent (B2BUA), sends the INVITE back to the S-CSCF (in step 4). Upon receiving the INVITE, the S-CSCF detects that another iFC condition is satisfied, and similarly directs the INVITE to the corresponding PacketCable AS (in step 5). The PacketCable AS performs the desired originating PacketCable service processing, and sends an INVITE back to the S-CSCF for termination handling (in step 6). Subsequent processing follows normal (IMS-based) processing. For CS terminations, the call is delivered via a MGC/MG (in steps 7 and 8), where SIP / ISUP interworking is performed. For PacketCable terminations, the INVITE is directed toward the target user (as illustrated in step 7a).

I.4 UE Origination Call Setup in CS Domain

This section describes the VCC signaling flow, associated with a call origination attempt by the UE in the CS domain. In this case, it is assumed that the UE was previously registered in the CS domain. This flow is common to both 3GPP and 3GPP2 VCC. (Distinctions between these flows are explicitly described in the following textual material.)

To allow the VCC AS to be inserted into the call flow signaling path, the use of WIN or CAMEL functionality is used for UE CS voice call originations. By applying an IN-based mechanism, the MSC is armed with the corresponding IN trigger (during CS registration processing), and this trigger condition is detected by the MSC for CS call originations. The overall flow is illustrated below. This figure is based on material that is included in section 6.2.1 of [TS 23.206], and in section 6.2.1 of [X.P0042-001] but has been extended to illustrate how originating PacketCable (e.g., RST) services can be offered via a separate PacketCable AS. This logic indicates that, for CS originations, the VCC AS is invoked first, prior to any other ASs for originating PacketCable services.

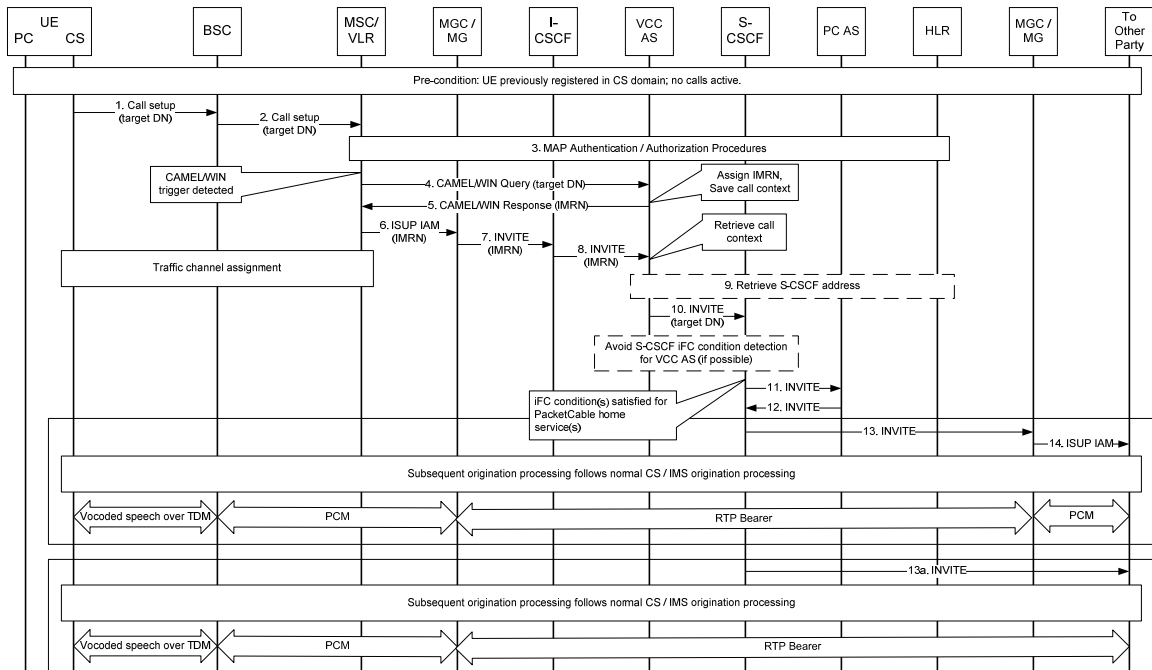

Figure 16 - UE Origination Call Setup in CS Domain

When the UE originates a call in the CS domain, normal CS origination procedures are initially invoked. The UE generates a call setup request, which is sent on to the visited MSC/VLR (as depicted in steps 1 and 2). The MSC/VLR determines whether authentication and/or authorization is required, and can invoke the associated MAP procedures at this time (step 3). For VCC CS call originations, the MSC/VLR is armed with an originating (CAMEL or WIN) trigger (armed during CS registration processing, as discussed in I.2). Upon detection of this trigger condition, the MSC/VLR sends a CAMEL/WIN Query (in step 4). This message is directed to the VCC AS, which assigns an IP Multimedia Routing Number (IMRN) for this call and retains information concerning the originating session. (The IMRN provides functionality that is analogous to the MSRN or TLDN in existing cellular networks, as used on terminating calls.) It causes the call to be routed via the PacketCable domain, and correlated back to the original CAMEL/WIN session. Note that the VCC AS may be configured in the HSS against a range of IMRNs wild-carded to the VCC AS PSI.) The VCC AS generates a CAMEL/WIN Response that instructs the MSC/VLR to route the call toward the assigned IMRN. The following table summarizes the specific messages used for the corresponding 3GPP (CAMEL) and 3GPP2 (WIN) procedures.

Table 9 - Intelligent Network Messages on CS Call Origination

Message	3GPP	3GPP2
CAMEL/WIN Query	InitialDP	OriginationRequest INVOKE (ORREQ)
CAMEL/WIN Response	Connect	OriginationRequest RETURN RESULT (orreq)

The MSC/VLR generates an ISUP IAM (in step 6), using the IMRN as the called number. The IAM is directed to a MGC either within the visited network or the UE's home PacketCable network (based on the choice of IMRN and associated network routing information). In step 7, the MGC generates an INVITE, using the IMRN (i.e., VCC AS PSI) to set the Request-URI. The I-CSCF performs a location query (to the HSS) to direct the INVITE (step 8) on to the VCC AS.

Upon receiving the incoming INVITE, the VCC AS uses the IMRN to correlate back to the previously-saved session information (e.g., to obtain the original target DN). The VCC AS retrieves the S-CSCF address in step 9 (e.g., via local information or from the HSS via the Sh interface - see section 5.7.3 of [PKT 24.229]) and invokes a B2BUA function to originate a session to the original target destination on behalf of the user (step 10). When the S-

CSCF receives the INVITE, it determines that an iFC condition is satisfied, and directs the INVITE to the corresponding PacketCable AS (step 11).

Note: Although the INVITE (in step 10) is originated by the VCC AS (operating in B2BUA mode), it appears to the S-CSCF as an originating INVITE from the UE. Upon receipt of this INVITE, the S-CSCF checks if any iFC conditions are satisfied. Whereas the iFC associated with PacketCable originations (per step 3 in Section I.3 of this document) would normally be satisfied, the corresponding iFC can be populated to avoid the detection of the VCC AS iFC in the current scenario. Otherwise, a superfluous INVITE (from the S-CSCF back to the VCC AS) would be sent prior to the current step 11, and the VCC AS would need to proxy it back to the S-CSCF.

The PacketCable AS performs the desired originating PacketCable service processing, and sends an INVITE back to the S-CSCF for termination handling (in step 12). Subsequent processing follows normal (IMS-based) processing. For CS terminations, the call is delivered via a MGC/MG (in steps 13 and 14), where SIP/ISUP interworking is performed. For PacketCable terminations, the INVITE is directed toward the target user (as illustrated in step 13a).

I.4.1 Media Path Optimization through MGC/MG Selection

There can be cases where an operator chooses to have the subscriber media path optimized for the VCC UE subscriber. For example, if a UE originates a call on the CS Cellular network (e.g., in an MSC in New York), it would be preferable for the media to be anchored in a MGC/MG that is geographically near that location, instead of having to anchor the media in a remote MGC/MG (e.g., on the US west coast).

To that effect, the MGC/MG (see step 6) can be selected for optimizing the media path. This can be achieved by the VCC AS MGC/MG selection logic based on the information it received in step 4, namely the mscaddress and location information parameters in the case of 3GPP, and MSCID and optional LocationAreaID in the case of 3GPP2. The IMRN selected by the VCC AS corresponds to the MGC/MG to be used in step 6, and further on for the media path.

For scenarios where the same MGC/MG is used by many PacketCable operators, the IMRN pool allocated to that MGC/MG would need to be segregated among the various PacketCable operators, thus creating sub-optimal (trunking inefficiency) use of the IMRN resources. This limitation exists assuming a static allocation of IMRNs per PacketCable operator for a given MGC/MG. Means for providing dynamic allocation of IMRN is out of scope.

Within the context of the media path optimization described here, it is assumed that the MGC/MG can either be owned by the PacketCable Operator (that is performing VCC anchoring on a call for one of its subscribers), or that MGC/MG can be owned by a different operator. The security aspects are out of scope for the latter case (where the MGC/MG is owned by a separate operator).

I.5 UE Termination Call Setup in PacketCable Domain

This section illustrates the VCC signaling flow associated with a call delivery attempt to a UE, whose DN is homed in the PacketCable domain. In this case, it is assumed that the UE was previously registered in the PacketCable domain (with the S-CSCF depicted in this figure serving as the registrar), and the call is delivered to the UE via the PacketCable domain. This flow is common to both 3GPP and 3GPP2 VCC.

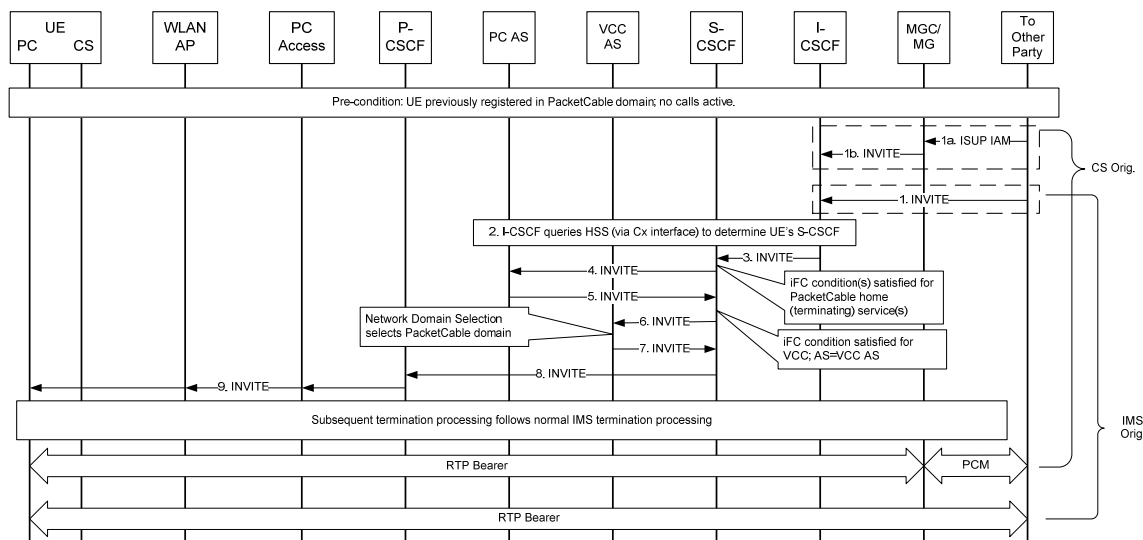

Figure 17 - UE Termination Call Setup in PacketCable Domain

Figure 17 is based on basic PacketCable call delivery procedures. It is consistent with material contained in Section 6.3.3 of [TS 23.206] and in Section 7.2 of [X.P0042-001], yet also includes interactions with terminating (e.g., RST) services offered via a separate AS in the PacketCable home network. This logic indicates that, for call terminations, the VCC AS is invoked last, after any PacketCable services.

When the caller originates a call to the UE, normal IMS procedures are initially invoked.

- For CS originations, an ISUP IAM is directed to an MGC (step 1a). The MGC determines the UE's SIP URI (e.g., via an ENUM query) and sends an INVITE to the I-CSCF in the UE's PacketCable home network (in step 1b).
- Alternatively, for IMS originations, an INVITE is directed to the I-CSCF in the UE's PacketCable home network (in step 1).

The I-CSCF performs a location query (to the HSS, in step 2) to direct the INVITE on to the designated S-CSCF (in step 3). For call terminations, the S-CSCF first directs the INVITE to the PacketCable AS (prior to invoking VCC AS processing), based on the priority associated with the corresponding iFC. The PacketCable AS performs the desired terminating PacketCable (e.g., RST) service processing, and sends an INVITE back to the S-CSCF (in step 5). When the S-CSCF receives the INVITE, it determines that an additional iFC condition is satisfied (associated with VCC AS processing) and directs the INVITE to the VCC AS (in step 6). Network Domain Selection is performed. In the case depicted in Figure 17, the VCC AS decides to direct the incoming call to the PacketCable domain. The VCC AS retains information concerning the session and, acting as a B2BUA, sends the INVITE back to the S-CSCF (in step 7). Subsequent call termination processing follows normal (PacketCable-based) call termination processing.

I.6 UE Termination Call Setup in CS Domain

This section illustrates the VCC signaling flow, associated with a call delivery attempt to a UE, whose DN is homed in the PacketCable domain. In this case, it is assumed that the UE was previously registered in the CS domain (with the MSC/VLR as depicted in this figure), and the call is delivered to the UE via the CS domain. This flow is common to both 3GPP and 3GPP2 VCC. (Distinctions between these flows are explicitly described in the following textual material.)

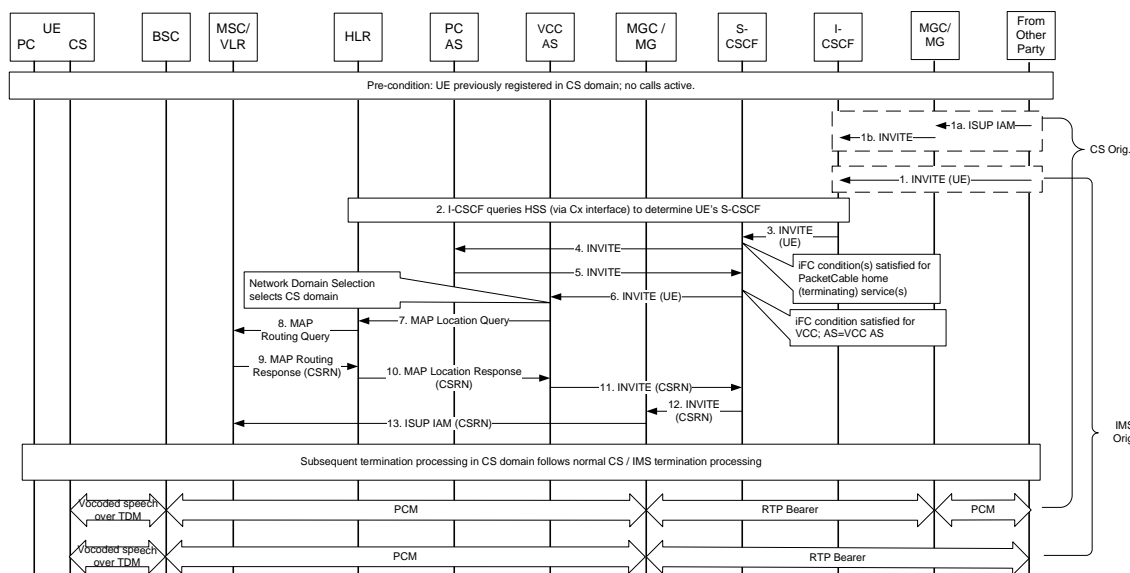

Figure 18 - UE Termination Call Setup in CS Domain

Figure 18 is based on basic PacketCable call delivery procedures, coupled with MAP messaging associated with call delivery. It is consistent with material contained in section 6.3.2 of [TS 23.206] and in section 7.1 of [X.P0042-001] yet includes interactions with terminating (e.g., RST) services offered via a separate AS in the PacketCable home network. This logic indicates that, for call terminations, the VCC AS is invoked last, after any PacketCable services.

When the caller originates a call to the UE, normal PacketCable procedures are initially invoked. Steps 1 - 6 are the same as depicted in the corresponding flow described in I.5. At that point, Network Domain Selection is performed. In the scenario as depicted in Figure 18, the VCC AS determines that the UE is registered in the CS domain, and decides to direct the incoming call to that domain. The VCC AS retains information concerning the session and it invokes basic call delivery procedures to obtain a Circuit Switched Routing Number (CSRN) for routing purposes, as depicted in steps 7 through 10. This involves a MAP Location Query to the UE's HLR (step 7). The HLR obtains the CSRN from the visited MSC/VLR (via a MAP Routing Query and corresponding response) and passes that CSRN back to the VCC AS via a MAP Location Response (in step 10).

Table 10 summarizes the specific messages used for the corresponding 3GPP and 3GPP2 procedures.

Table 10 - Intelligent Network Messages on CS Call Termination

Message	3GPP	3GPP2
MAP Location Query / Response	SendRoutingInformation (SRI) / SRI response	LocationRequest INVOKE (LOCREQ) / locreq response
MAP Routing Query / Response	ProvideRoamingNumber (PRN) / PRN response	RoutingRequest INVOKE (ROUTREQ) / routreq response
CSRN	Mobile Station Roaming Number (MSRN)	Temporary Local Directory Number (TLDN)

The VCC AS generates an INVITE using the received CSRN, and, acting as a B2BUA, sends the INVITE back to the S-CSCF (in step 11). Subsequent call termination processing follows normal (PacketCable/CS-based) call termination processing.

I.6.1 Media Path Optimization through MGC/MG Selection

There can be cases where an operator chooses to have the subscriber media path optimized for the VCC UE subscriber. For example, if a call terminates to a UE on the CS Cellular network, and the UE is currently roaming (e.g., in an MSC in New York), it would be preferable to select a MGC/MG that is geographically near that location, rather than breaking out to CS out of a MGC/MG located in its home network (e.g., on the US west coast).

On the terminating side the MGC/MG is selected by the BGCF (step 12). As there is no more information about the VCC UE's current location available than the CSRN retrieved by the VCC AS from the CS network (steps 7-10), the BGCF's routing table needs to reflect the mapping of CSRN number ranges to the MGC/MGs closest to each CSRN's VMSC. The CSRN is a temporary number allocated by the current VMSC and as such is prefixed with country codes and area codes, which can be used for routing. Retrieving this routing information and configuration of the BGCF is left to the operator and not covered in this specification.

Within the context of the media path optimization described here, it is assumed that the MGC/MG can either be owned by the PacketCable Operator (that is performing VCC anchoring on a call for one of its subscribers), or that MGC/MG can be owned by a different operator. The security aspects are out of scope for the latter case (where the MGC/MG is owned by a separate operator).

I.7 CS to PacketCable VCC Domain Transfer Procedure for 2 Party Call

This section illustrates the VCC signaling flow, associated with a domain transfer of a UE from the CS domain to the PacketCable domain. In this case, it is assumed that the UE was previously registered in both the CS and PacketCable domains (i.e., UE is dual-registered), with an existing CS call active. (If not already registered in the PacketCable domain, PacketCable registration procedures are first invoked. This is as illustrated in the PacketCable registration flow.) This flow is common to both 3GPP and 3GPP2 VCC.

Figure 19 is based on corresponding CS to WLAN procedures, as contained in section 6.4.2.2 of [TS 23.206] and in section 10 of [X.P0042-001]. It is noted that domain transfer can entail potential interactions with PacketCable (e.g., RST) services offered via a separate AS in the PacketCable home network, as indicated in the following figure.

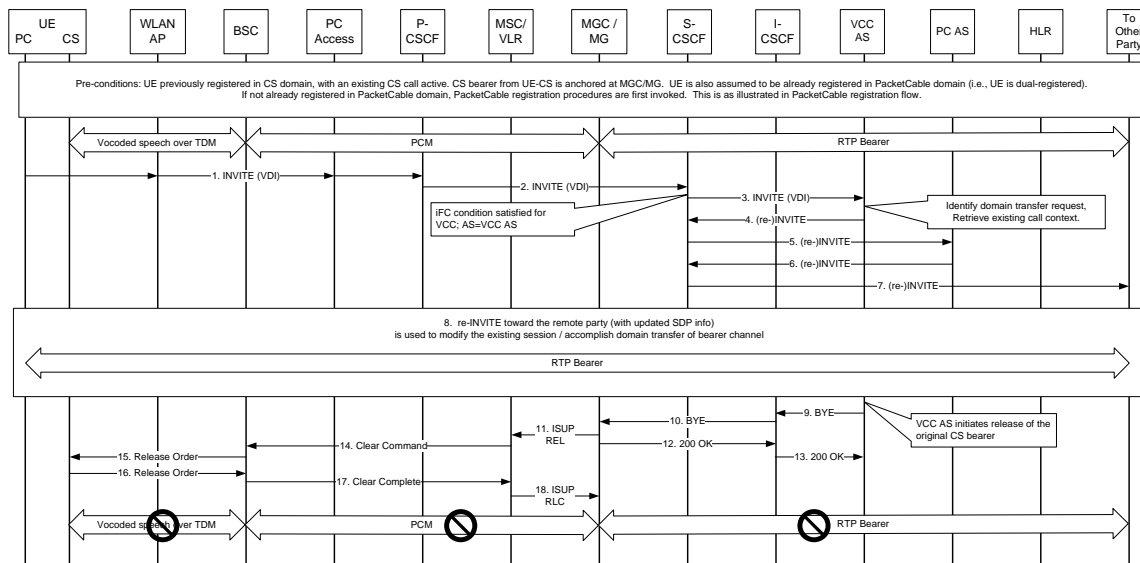

Figure 19 - UE Domain Transfer from CS Domain to PacketCable Domain

When the UE determines that a CS-to-PacketCable domain transfer is required, it initiates PacketCable origination procedures. Steps 1 to 3 are as discussed in Section I.3, involving the sending of an INVITE that is delivered to the VCC AS. In this case, the UE includes a VDI value that identifies this as a domain transfer request. The VCC AS

identifies the INVITE as a domain transfer request, retrieves the associated information related to the existing CS call, and initiates the domain transfer procedure.

Note: In the simplest case (for 2-party call domain transfer), the VDI populated by the UE can contain a simple service code to identify this as a domain transfer attempt. Additional digits might also be added to identify a particular session, in order to provide an extensible mechanism that can also be used with multi-party domain transfers to identify a particular leg being transferred (if required).

The VCC AS sends a (re-)INVITE to the S-CSCF (with SDP information received from the UE) to modify the existing bearer path from the UE toward the remote party (step 4). At this point, if record routing was previously requested, the INVITE is sent to the PacketCable AS (as illustrated in steps 5 and 6), prior to sending the INVITE toward the remote party (step 7).

When the new bearer path is being established, the VCC AS initiates procedures to drop the previous CS bearer connection from the MGC towards the UE. This involves the sending of a BYE method (depicted as step 9), followed by normal ISUP release procedures back towards the UE.

Note: Whereas Figure 19 depicts the BYE method being routed via the S-CSCF toward the VCC UE, it is noted that the BYE method can alternately be routed via the I-CSCF, depending upon how the original CS call was established (e.g., if the original CS call was established as depicted in Section I.4).

I.8 PacketCable to CS VCC Domain Transfer Procedure for 2 Party Call

This section illustrates the VCC signaling flow, associated with a domain transfer of a UE from the PacketCable domain to the CS domain. In this case, it is assumed that the UE is previously registered in the PacketCable domain (and can be registered in the CS domain), with an existing PacketCable call active. This flow is common to both 3GPP and 3GPP2 VCC. (Distinctions between these flows are described below.)

Procedures for WLAN VoIP to CS domain transfers are described in section 6.4.2.1 of [TS 23.060] and in section 9.2 of [X.P0042-001]. The current figure also illustrates potential interactions with PacketCable RST services.

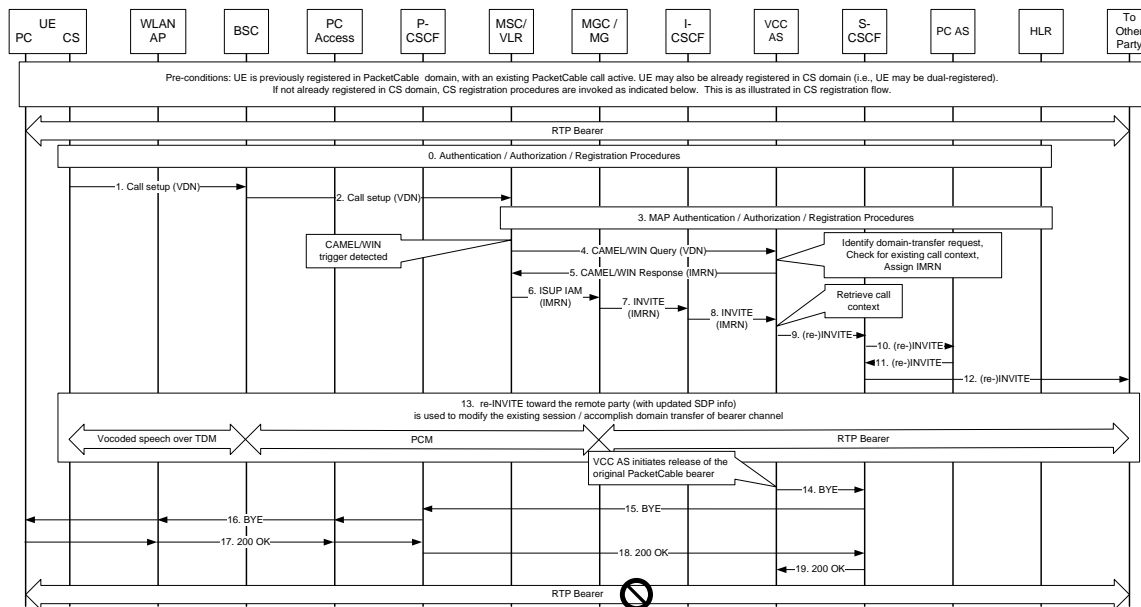

Figure 20 - UE Domain Transfer from PacketCable Domain to CS Domain

When the UE determines that a PacketCable-to-CS domain transfer is required, the UE initiates domain transfer procedures (as illustrated in steps 1 through 8 of the Figure). This processing is analogous to the processing as

discussed in I.4 (for VCC CS originations), including the use of CAMEL or WIN to support the insertion of the VCC AS into the signaling path. A distinction is that registration procedures are needed (since this scenario assumes that the UE was not previously registered in the CS domain - unlike the corresponding scenario depicted in Section I.4).

Note: The UE can explicitly invoke registration procedures prior to sending the domain transfer request (as illustrated in step 0 of Figure). 3GPP requires such an explicit registration prior to call setup. ANSI-41 also supports implicit registration (as indicated in step 3), where the MSC/VLR invokes such processing upon receiving the call setup request.

Also, this scenario assumes that the UE, upon detecting the need to invoke domain transfer, will include a VDN value that identifies this as a domain transfer request. When the VCC AS receives these digits in the CAMEL/WIN Query, it identifies this as a domain transfer request, retrieves the associated information related to the existing CS call, and initiates the domain transfer procedure.

Note: In the simplest case (for 2-party call domain transfer), the VDN populated by the UE can be a simple service code to identify this as a domain transfer attempt. Additional digits might also be added to identify a particular session, in order to provide an extensible mechanism that can also be used with multi-party domain transfers to identify a particular leg being transferred (if required).

The VCC AS sends a (re-)INVITE to the S-CSCF (with SDP information related to the MG) to modify the existing bearer path from the UE toward the remote party (step 9). At this point, if record routing was previously requested, the S-CSCF can send the INVITE to a PacketCable AS (as illustrated in steps 10 and 11), prior to sending the INVITE toward the remote party (in step 12).

When the new bearer path is being established, the VCC AS initiates procedures to drop the previous bearer connection from the UE towards the remote party. This involves the sending of a BYE toward the UE (depicted as step 14), which initiates normal PacketCable release procedures.

Appendix II Domain Transfer of Calls on Hold, Calls in Wait and N-Way Calls Flows (INFORMATIVE)

II.1 Call Hold Flows

II.1.1 CS to PacketCable Domain Transfer

II.1.1.1 3GPP CS to PacketCable

Figure 21 provides an informative flow for domain transfer of an active call and of a call on hold made using VCC UE in CS domain to IMS direction. The flow is based on the precondition that the user is active in one CS voice originating or terminating session and has one other call on hold at the time of initiation of the domain transfer to IMS.

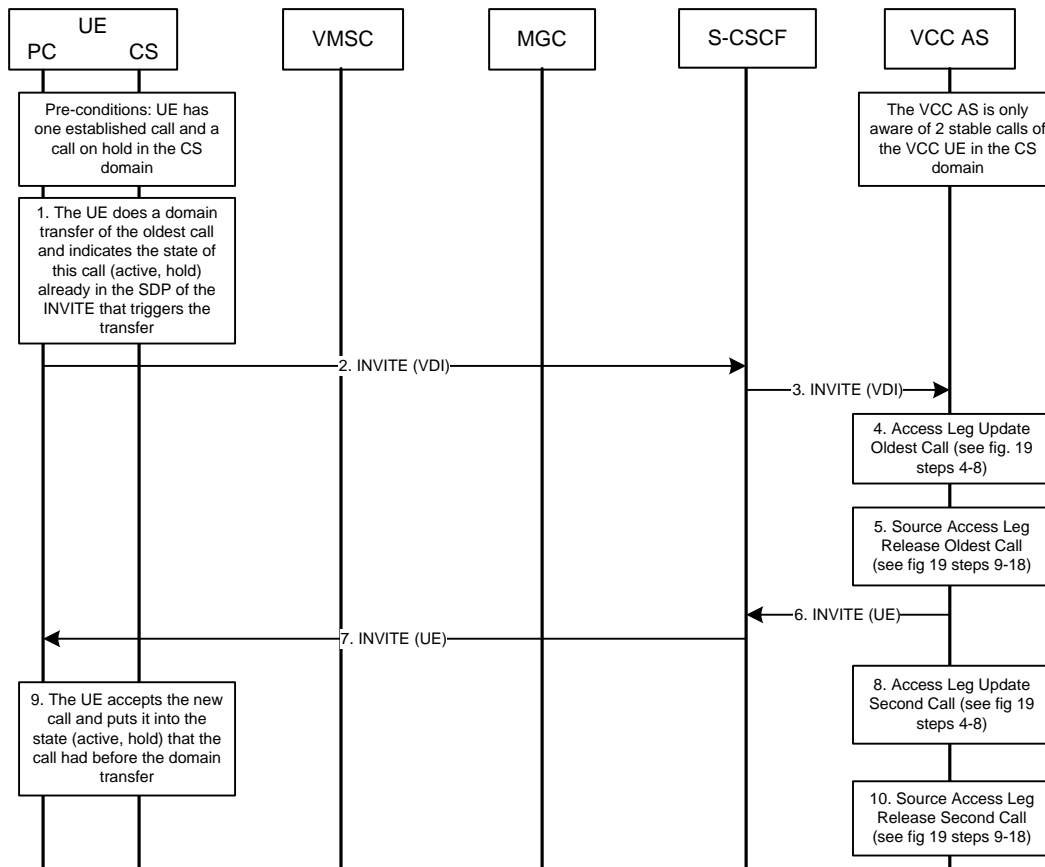

Figure 21 - Domain Transfer of a Call on Hold: CS domain to IMS

1. If the user is not registered in the IMS at the time when the UE determines a need for a domain transfer to the IMS, the UE initiates a registration with the IMS as specified in section 6.1 "Registration" of [TS 23.206].
2. The VCC UE subsequently initiates an IMS originated session toward the VCC AS to establish an access leg via the IMS and requests a domain transfer of the oldest active CS session to the IMS indicating this call's status (active, hold) already in the INVITE. The VCC AS is aware that the UE has more than one

active call, but it is not aware that there is one call on hold. Please refer to section 6.2 "Origination" of [TS 23.206] for details on the IMS origination procedure.

3. The IMS session is processed at the S-CSCF and delivered to the VCC AS as specified in section 6.2 "Origination" of [TS 23.206].
4. The VCC AS completes the establishment of the access leg via the IMS. The VCC AS performs the Domain Transfer by updating the Remote Leg of the oldest active CS session with connection information of the newly established access leg using the access leg update procedure as specified in section 6.4.1.3 "Access Leg Update toward the remote end" of [TS 23.206].
5. The source access leg which is the access leg previously established over CS is subsequently released as specified in section 6.4.1.4 "Source Access Leg Release" of [TS 23.206].
6. The VCC AS initiates a call towards the UE to trigger the transfer of the next call. The INVITE is sent to the S-CSCF on behalf of the next B-Party.
7. The S-CSCF forwards the INVITE to the VCC UE.
8. The VCC AS performs access leg update procedure as specified in step 4 toward the remote end for the second call.
9. The UE re-establishes the state (active, hold) that the call had before the transfer.
10. The source access leg of the second call which is the access leg previously established over CS is subsequently released.

Although this example only presents the domain transfer of a single active call and a single call on hold, it works with any number of calls.

II.1.1.2 3GPP2 CS to PacketCable

3GPP2 does not have a call hold feature that is separable from call wait or 3WC. Therefore, the domain transfer of 3GPP2 call hold states is shown within call wait and 3WC features.

II.1.2 PacketCable to CS Cellular Domain Transfer

II.1.2.1 PacketCable to 3GPP CS

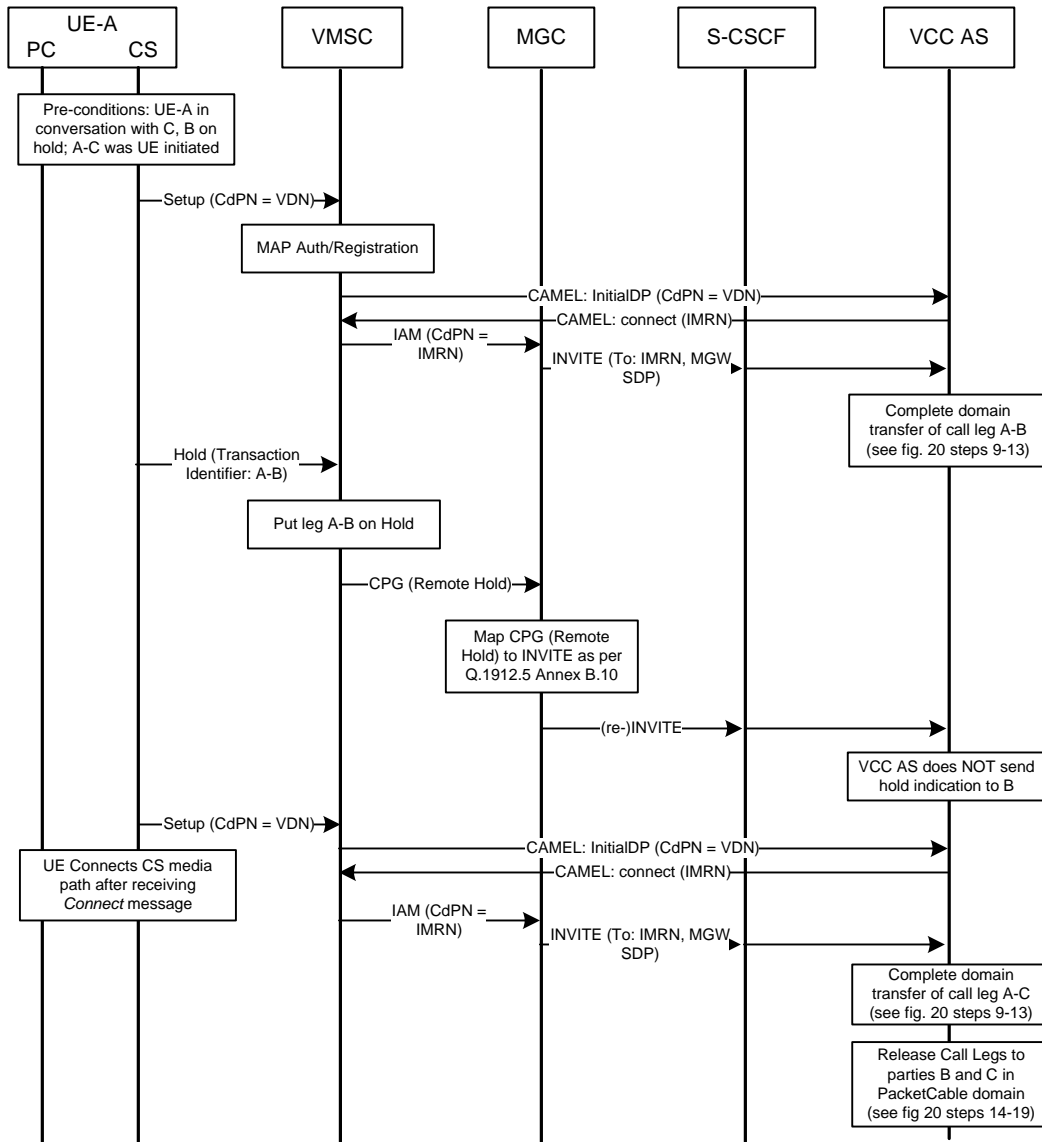

Figure 22 - PC to 3GPP CS - A-B on hold prior to transfer, A-C was UE initiated

For the flow in Figure 22, the 3GPP Hold, Hold Acknowledge and Setup (CdPN: VDN) messages from the UE are UE-initiated apart from user intervention.

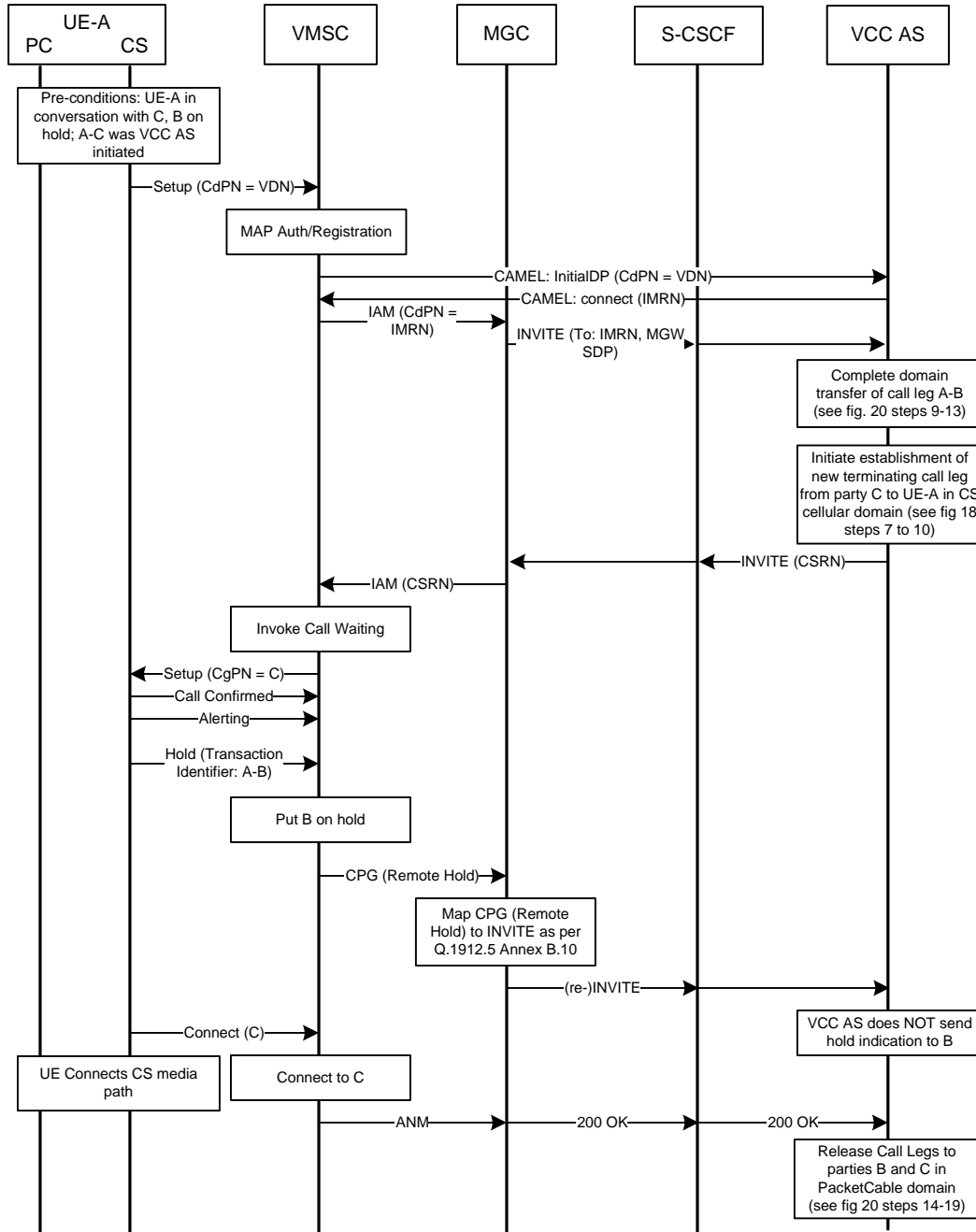

Figure 23 - PC to 3GPP CS, A-B on hold prior to transfer, A-C was VCC AS initiated

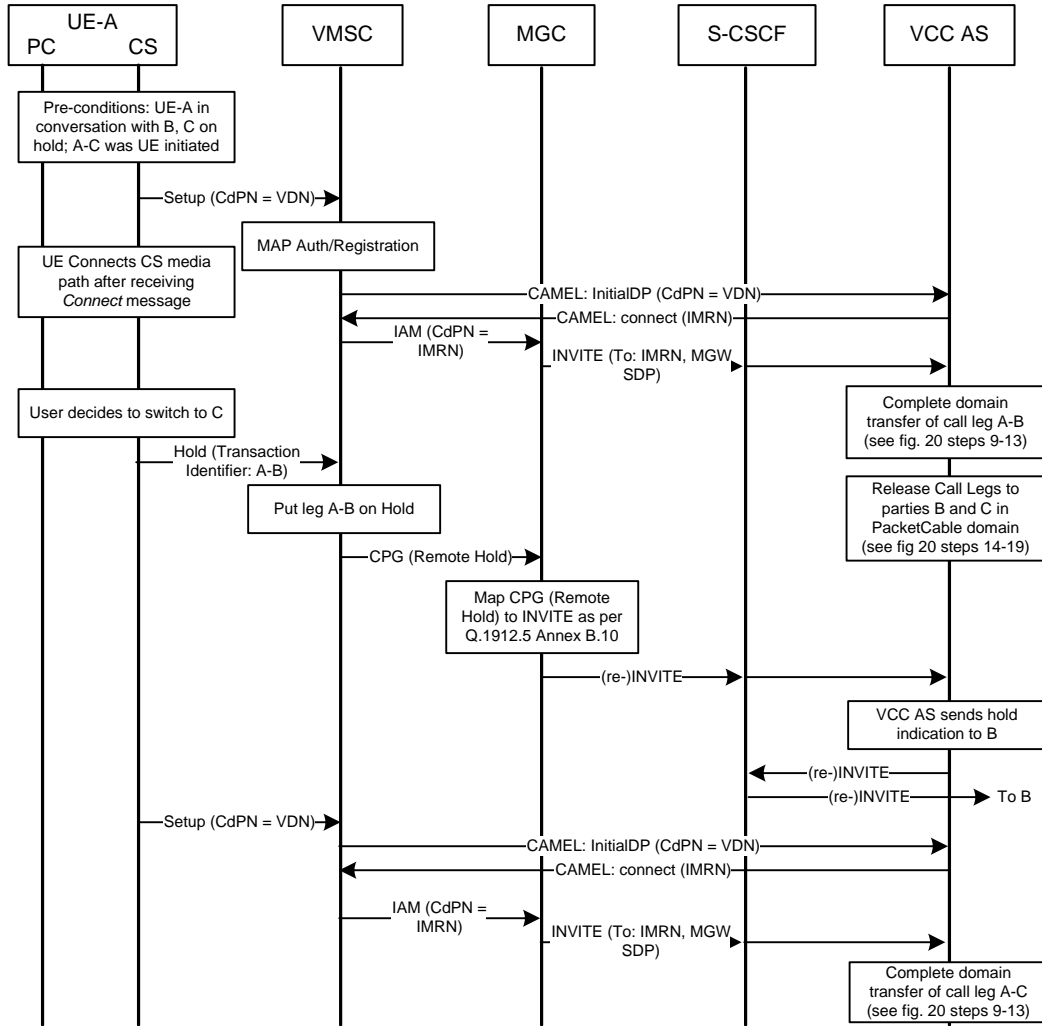

Figure 24 - PacketCable to 3GPP CS Transfer of Call Hold and 3WC Establishment, A-B active prior to transfer, A-C was UE initiated (1 of 2)

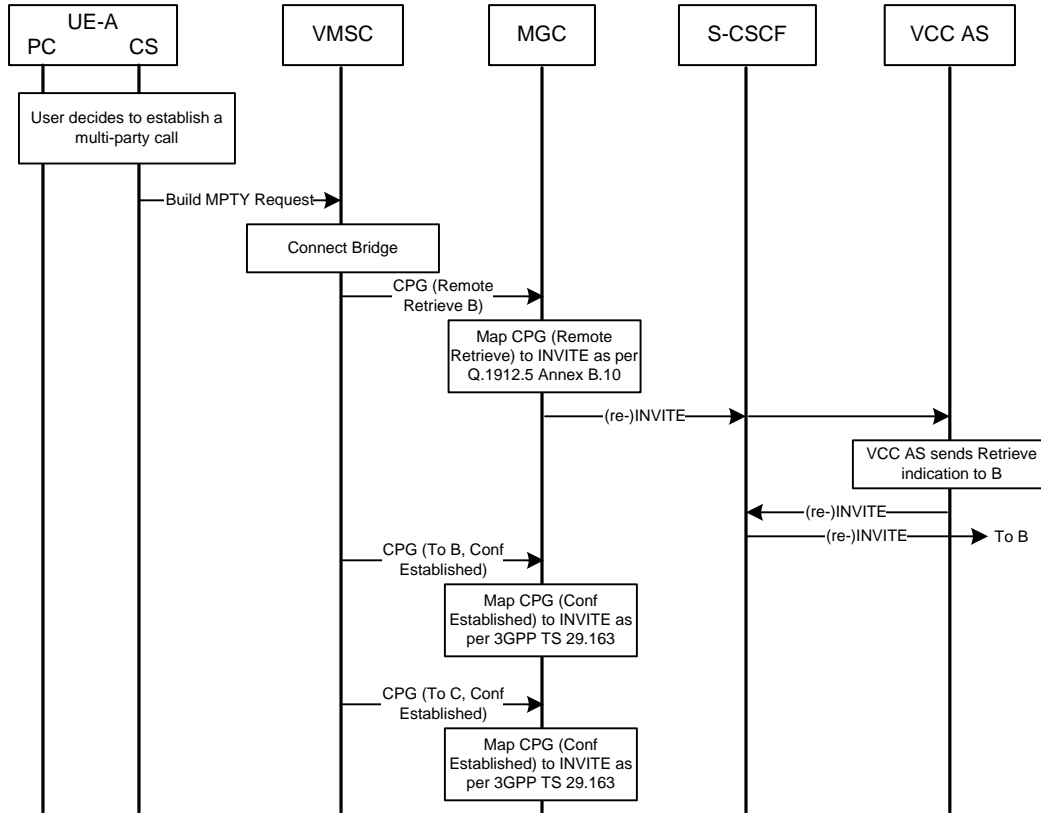

Figure 25 - PacketCable to 3GPP CS Transfer of Call Hold and 3WC Establishment, A-B active prior to transfer, A-C was UE initiated (2 of 2)

The pre-conditions for flows Figure 24, Figure 25, and Figure 28 assume support of a "dial-able call hold" feature in the PacketCable domain prior to transfer. In this scenario, both the UE and VCC AS know that the A-C call is on hold but do nothing until the user decides to switch to party C. Thus, the Hold message is user-initiated; however, the follow-on Setup is UE-initiated apart from user intervention. This behavioral model requires an adjusted CS domain state machine in the 3GPP UE.

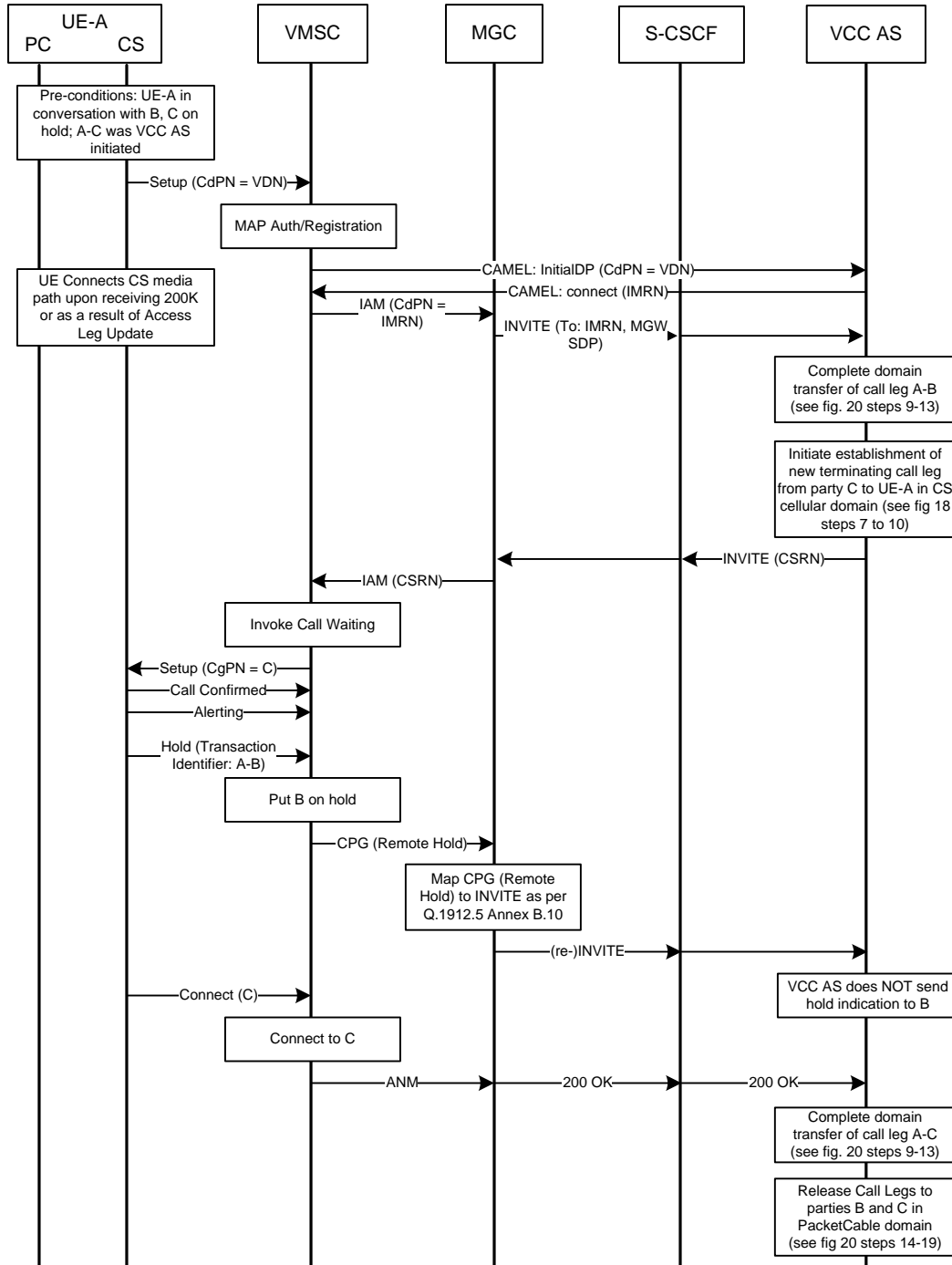

Figure 26 - PacketCable to 3GPP CS Transfer of Call Hold, A-B active prior to transfer, A-C was VCC AS initiated (1 of 2)

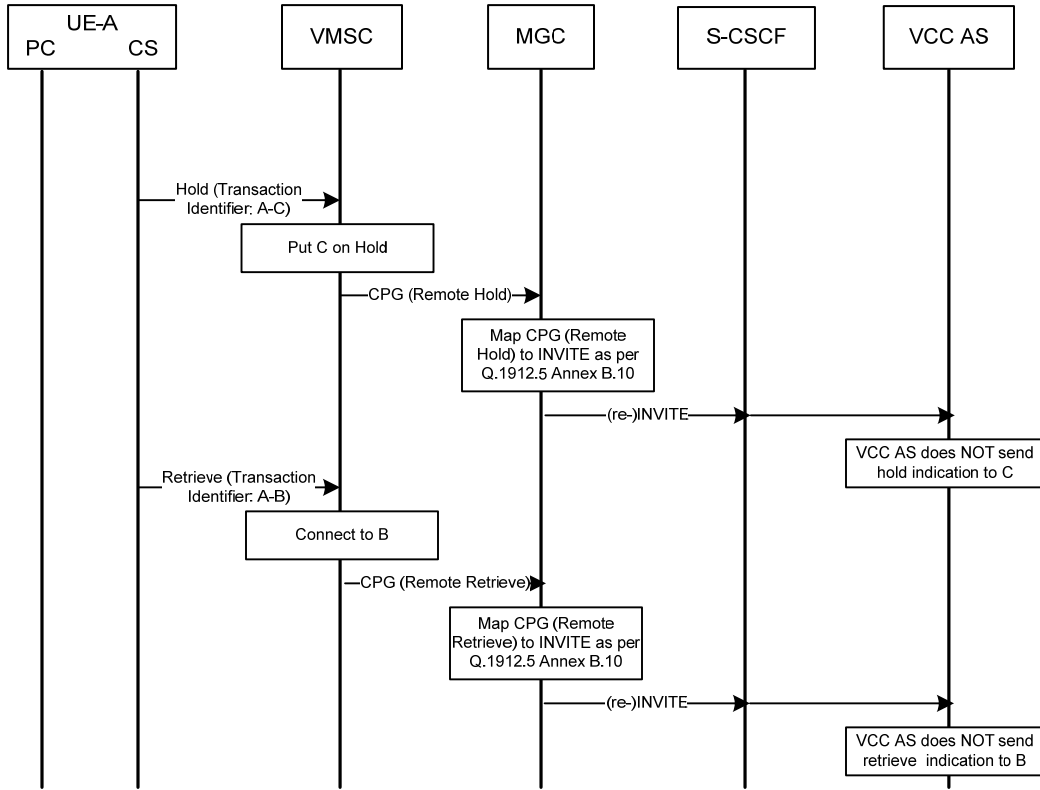

Figure 27 - PacketCable to 3GPP CS Transfer of Call Hold, A-B active prior to transfer, A-C was VCC AS initiated (2 of 2)

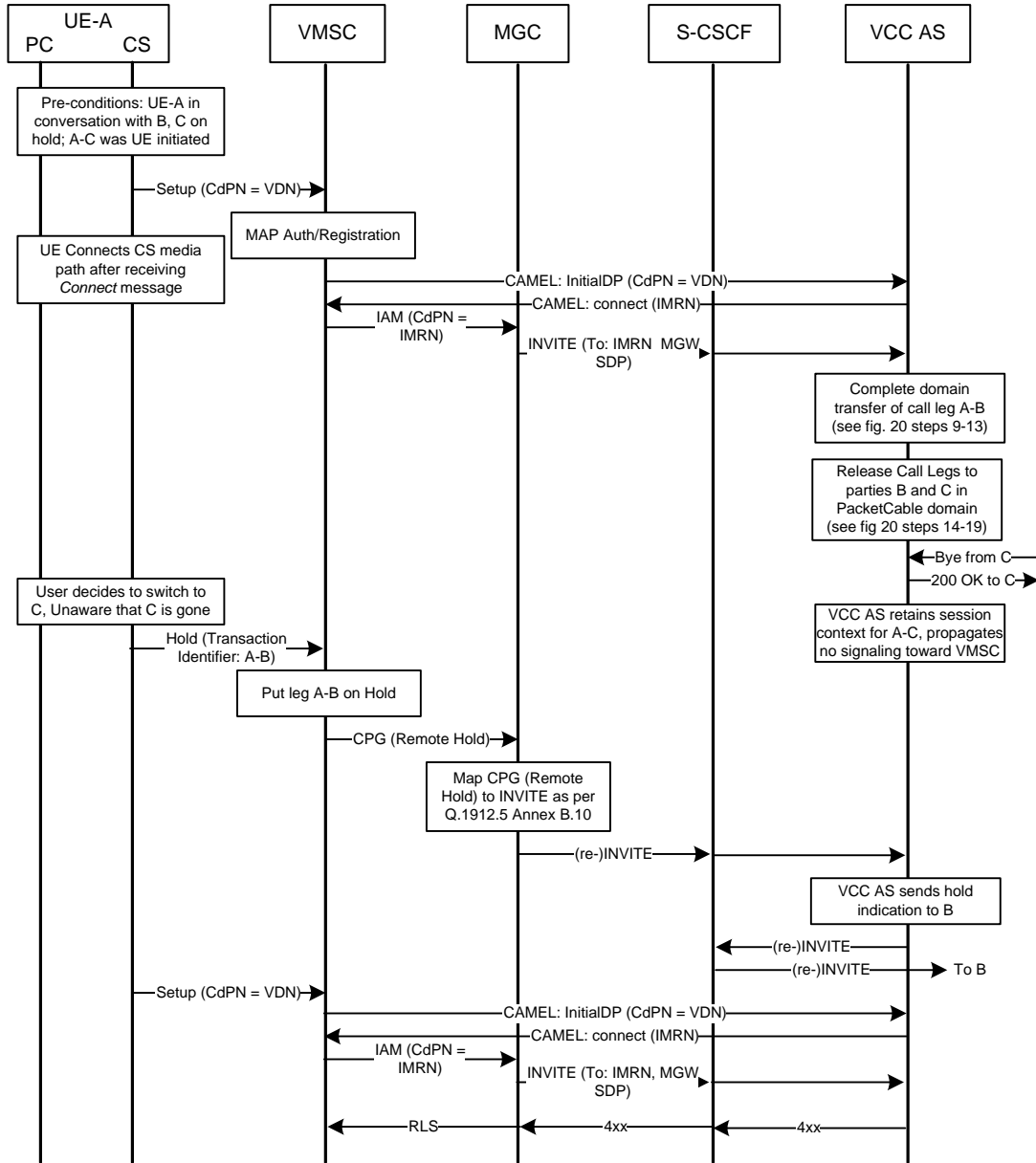

Figure 28 - PacketCable to 3GPP CS Transfer of Call Hold, A-B active prior to transfer, A-C was UE initiated, C Disconnects While on Hold

II.1.2.2 PacketCable to 3GPP2 CS

3GPP2 does not have a call hold feature that is separable from call wait or 3WC. Therefore, the domain transfer of 3GPP2 call hold states is shown within call wait and 3WC features.

II.2 Call Waiting Domain Transfer Flows

II.2.1 CS to PacketCable Domain Transfer

II.2.1.1 3GPP CS to PacketCable

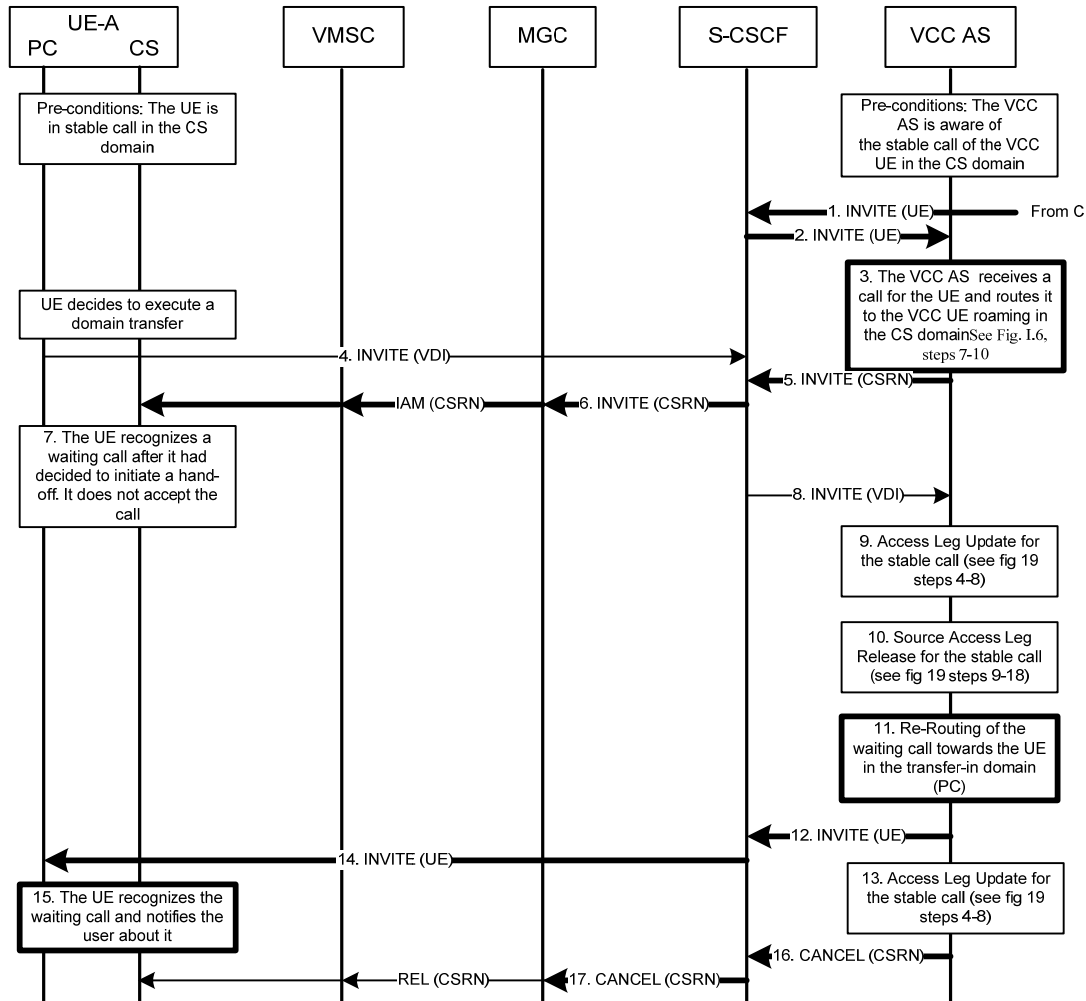

Note: Items in “**BOLD**” belong to the “Waiting” call

Figure 29 - Domain Transfer of Call Waiting: CS domain to PacketCable

1. A new call directed to the VCC UE arrives at the user's S-CSCF.
2. The S-CSCF triggers the VCC AS (iFC).
3. The VCC AS that is aware of the active call(s) of the VCC UE in the CS domain routes the session request towards the UE using the same domain that had been used for the currently active call(s).
4. If the user is not registered in PacketCable at the time when the UE determines a need for a domain transfer to the PacketCable, the UE initiates a registration with PacketCable as specified in section 6.1 "Registration" of [TS 23.206]. It subsequently initiates a PacketCable originated session toward the VCC AS to establish an Access Leg via the PacketCable and requests a Domain Transfer to the PacketCable. Please refer to Appendix I, which is consistent with section 6.2 "Origination" of [TS 23.206], for details on the PacketCable origination procedure.

5. The VCC AS sends the INVITE back to the S-CSCF for routing to the VCC UE in the CS domain.
6. The S-CSCF routes the call to the VCC UE roaming in the CS domain (BGCF, MGC, VMSC are not shown).
7. The VCC UE recognizes a new call in the CS domain. Since it has already initiated a domain transfer procedure towards the IMS, it does not present the call as "call waiting" to the user.
8. The domain transfer to PacketCable session is processed at the S-CSCF and delivered to the VCC AS as specified in Appendix I, which is consistent with section 6.2 "Origination" of [TS 23.206].
9. The VCC AS completes the establishment of the access leg via the PacketCable. The VCC AS performs the Domain Transfer by updating the Remote Leg of the oldest active CS session with connection information of the newly established access leg using the access leg update procedure as specified in Appendix I, which is consistent with section 6.4.1.3 "Access Leg Update toward the remote end" of [TS 23.206].
10. The source access leg which is the access leg previously established over the CS domain is subsequently released as specified in Appendix I, which is consistent with section 6.4.1.4 "Source Access Leg Release" of [TS 23.206].
11. After the domain transfer has been completed, the VCC AS decides to create a new leg for the call waiting towards the VCC UE in the "transfer-in" domain (the PacketCable).
12. The VCC AS sends the INVITE to the S-CSCF.
13. The VCC AS updates the Remote Leg of the oldest active CS session with connection information of the newly established access leg using the access leg update procedure as specified in Appendix I, which is consistent with section 6.4.1.3 "Access Leg Update toward the remote end" of [TS 23.206].
14. The S-CSCF sends the INVITE to the VCC UE roaming in the PacketCable.
15. The VCC UE recognizes a call waiting and notifies the user for acceptance.
16. Finally, the VCC AS initiates the release of CS resources in the "transfer-out" domain that had been originally allocated for the call waiting and sends a CANCEL to the S-CSCF.
17. The S-CSCF sends the CANCEL/REL towards the CS domain (BGCF, MGC, VMSC are not shown).

II.2.1.2 3GPP2 CS to PacketCable

See Figure 29.

II.2.2 PacketCable to CS Domain Transfer

II.2.2.1 PacketCable to 3GPP CS

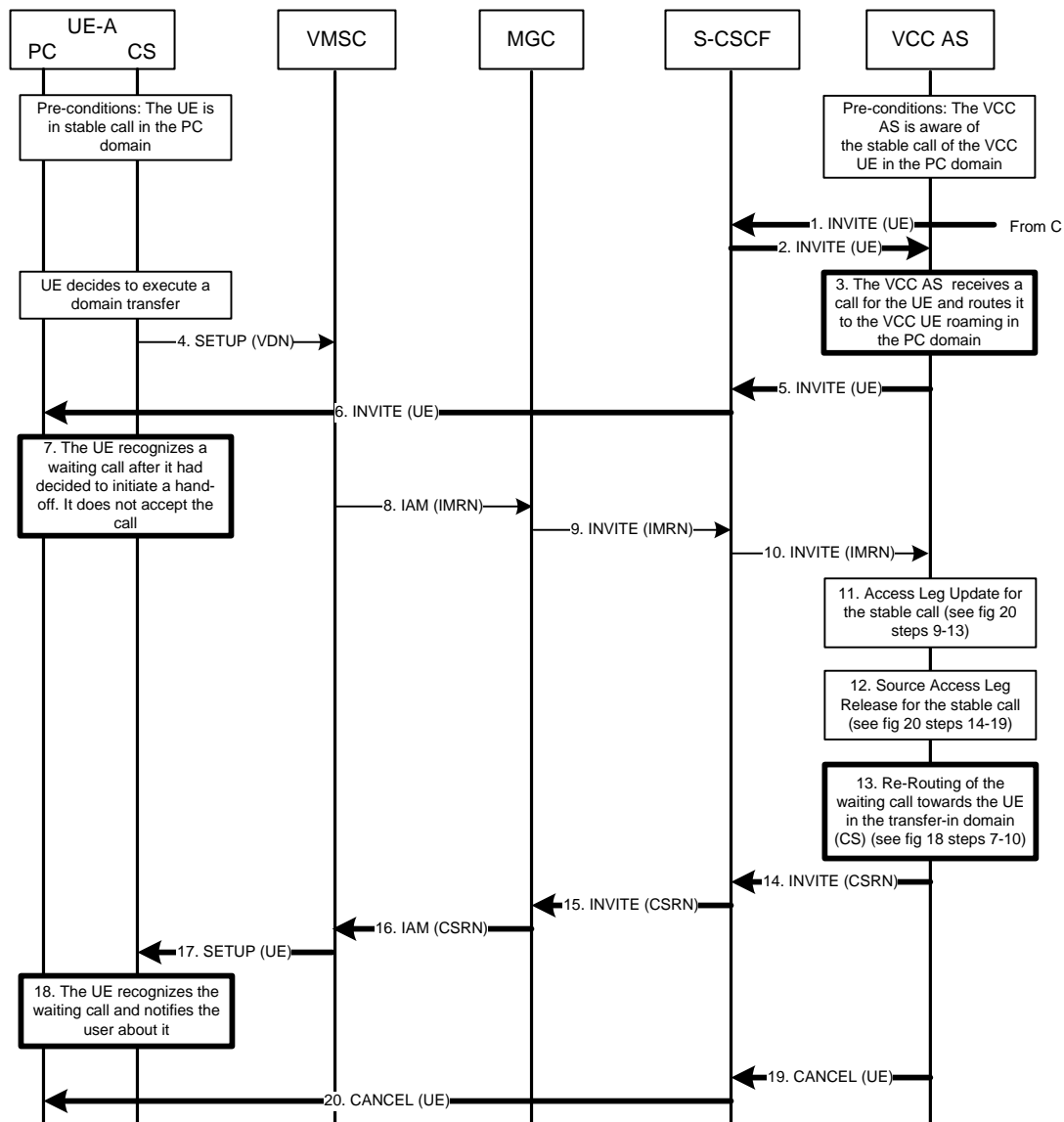

Note: Items in "BOLD" belong to the "Waiting" call

Figure 30 - Domain Transfer for a Call waiting: PC to CS domain

1. A new call directed to the VCC UE arrives at the user's S-CSCF.
2. The S-CSCF triggers the VCC AS (iFC).
3. The VCC AS that is aware of the active call(s) of the VCC UE in the PacketCable routes the session request towards the UE using the same domain that had been used for the currently active call(s).
4. If the user is not registered in the CS at the time when the UE determines a need for a Domain Transfer to the CS, the UE initiates CS domain registration (IMSI attach) as specified in section 6.1 "Registration" of [TS 23.206]. It subsequently originates a voice call in the CS domain according to "Information flow for an MO call" in [TS 23.018] using the VDN to establish an access leg via the CS domain and request Domain Transfer

of the oldest active IMS session to CS domain. Please refer to section 6.2 "Origination" of [TS 23.206] for details on the IMS origination procedure.

5. The VCC AS sends the INVITE back to the S-CSCF for routing to the VCC UE in the PacketCable.
6. The S-CSCF routes the call to the VCC UE roaming in the PacketCable.
7. The VCC UE recognizes a new call in the PacketCable. Since it has already initiated a domain transfer procedure towards the CS domain, it does not present the call as "call waiting" to the user.
8. The originating call is processed in the CS network according to CS origination procedures described in section 6.2 in "Origination" of [TS 23.206] for routing to PacketCable. The IMRN is resolved using the VFN at the CS network. The VMSC routes the call towards the user's home PacketCable network via an MGC in the home network.
9. The MGC initiates an INVITE towards the home PacketCable of the originating VCC user (I CSCF not shown). The PacketCable routes the INVITE to the VCC AS based on one of the following standard procedures specified in "PSI based Application Server termination - direct" and "PSI based Application Server termination - indirect" procedures in [TS 23.228].
10. The routing via S-CSCF is shown, although direct routing to the VCC AS is possible.
11. The VCC AS completes the establishment of the Access Leg via the CS domain. The VCC AS performs the Domain Transfer by updating the Remote Leg of the oldest active CS session with connection information of the newly established Access Leg using the Access Leg Update procedure as specified in section 6.4.1.3 "Access Leg Update toward the remote end" of [TS 23.206].
12. The source access leg which is the access leg previously established over IMS is subsequently released as specified in section 6.4.1.4 "Source Access Leg Release" of [TS 23.206].
13. After the domain transfer has been completed, the VCC AS decides to create a new leg for the call waiting towards the VCC UE in the "transfer-in" domain (the CS domain).
14. The VCC AS sends an INVITE using the CS domain routing number as request URI toward the S-CSCF as specified in section 6.3.2 "Terminated Call Directed to CS" of [TS 23.206]
15. The S-CSCF routes the INVITE toward the CS domain according [TS 23.228].
16. The MGC routes the call towards the VMSC of the VCC UE.
17. The VMSC presents the call waiting to the VCC UE.
18. The VCC UE indicates the call waiting to the user.
19. Finally, the VCC AS initiates the release of PacketCable resources in the "transfer-out" domain that had been originally allocated for the call waiting and sends a CANCEL to the S-CSCF.
20. The S-CSCF sends the CANCEL towards the UE (P-CSCF is not shown).

II.2.2.2 PacketCable to 3GPP2 CS

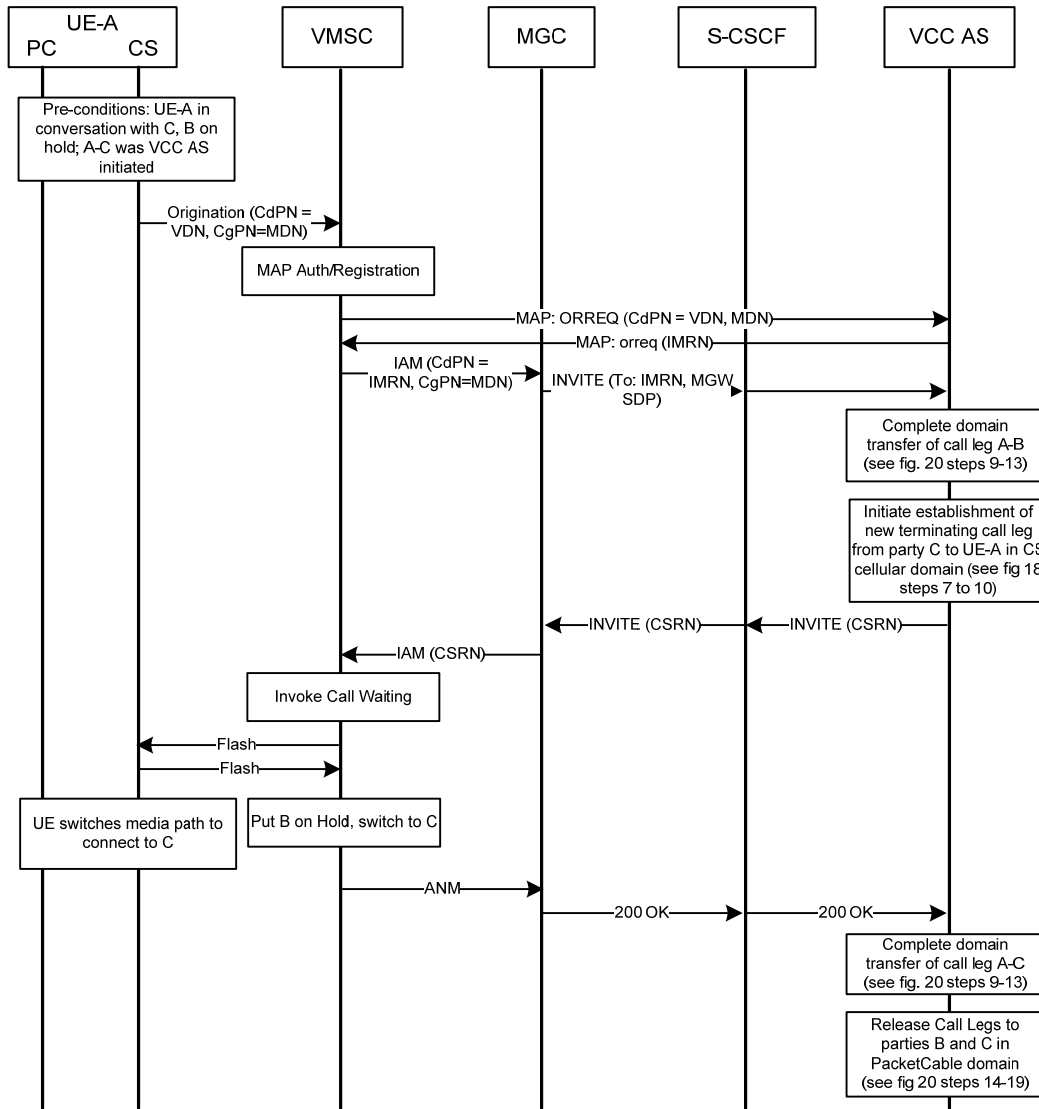

Figure 31 - PC to 3GPP2 CS Transfer of call waiting, A-B on Hold prior to Transfer, A-C was VCC AS Initiated

In Figure 31, it is expected that the Flash message from the UE is UE-initiated apart from user intervention.

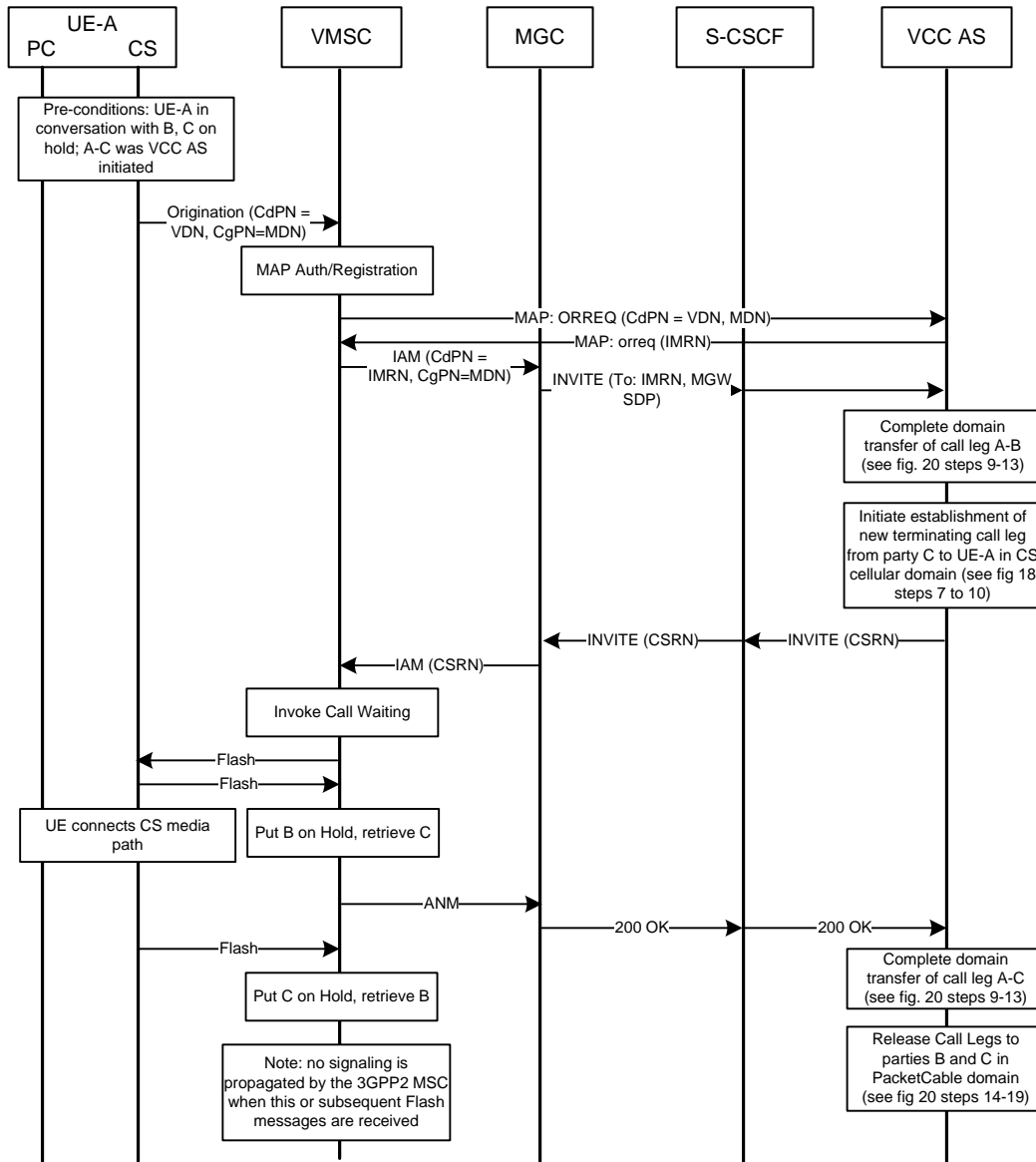

Figure 32 - PC to 3GPP2 CS Transfer of Call Waiting, A-B Active prior to Transfer, A-C was VCC AS Initiated

For the flow in Figure 32, when the VCC AS receives the 200 OK in reply to the INVITE for the A-C call, it releases the PacketCable hold condition. Subsequently, all hold and switch actions are controlled locally by the 3GPP2 MSC. The consequence of this model is that the user associated with C may perceive his or her session to be active when in fact it is held at the MSC.

II.3 N-way Call Domain Transfer Flows

Domain transfer of the controller of an N-way call features is generally not recommended since there is currently no standard way to domain transfer control of the conference. Therefore, the flow in this section is limited to the domain transfer of a call hold state prior to the formation of a 3GPP2 3WC conference.

II.3.1.1 PacketCable to 3GPP2 CS

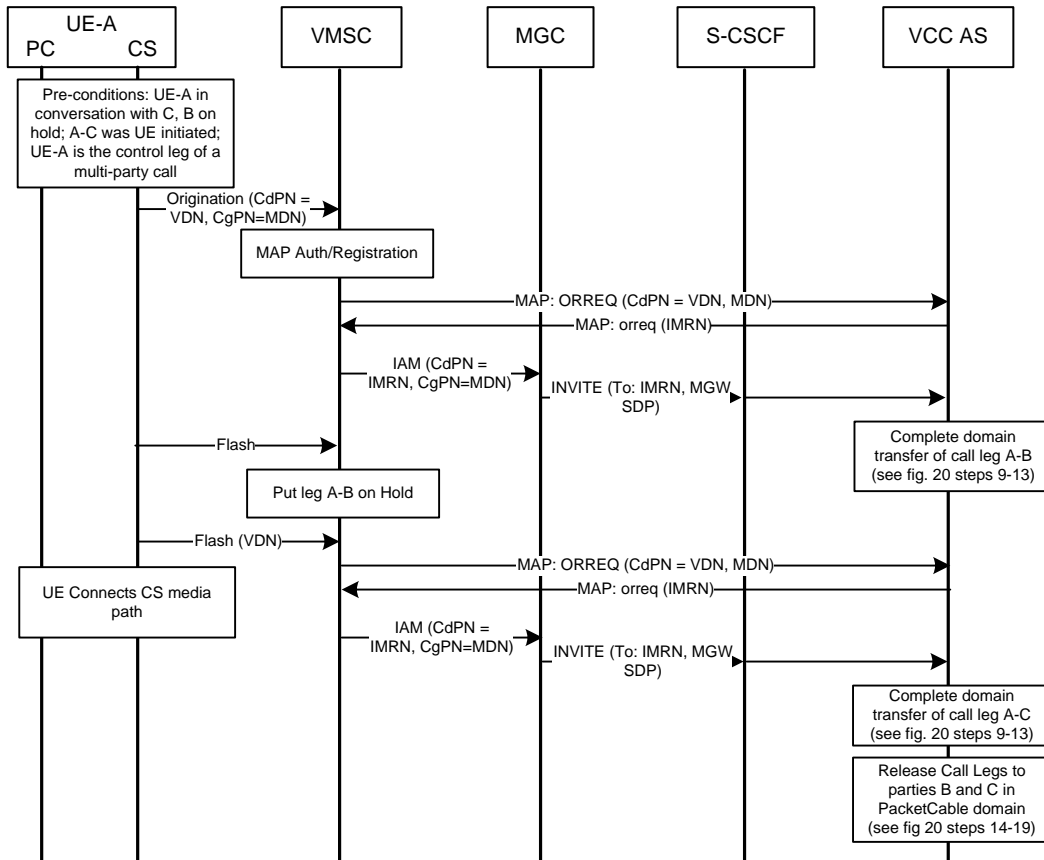

Figure 33 - PacketCable to 3GPP2 CS Transfer of Multi-Party Call, A-B on Hold prior to Transfer, A-C was UE Initiated

In Figure 33, it is expected that the 3GPP2 Flash message from the UE is UE-initiated apart from user intervention.

Appendix III 3GPP2 VCC References

The following table provides a summary of the 3GPP2 VCC section references as applicable to this document. The corresponding 3GPP2 VCC references are [X.P0042-001] (3GPP2 VCC Stage 2) and [X.P0042-002] (3GPP2 VCC Stage 3). In addition, this table summarizes some of the exclusions, modifications, clarifications, and extensions to the corresponding 3GPP2-VCC standards, as applicable for PacketCable VCC.

Table 11 - Summary of 3GPP2 VCC References

Function	Stage 2	Stage 3 - UE	Stage 3 VCC AS	PacketCable Exclusions, Modifications and Extensions
VCC AS Interfaces	4	-	-	Intervening WIN SCP not required VCC AS - HSS (Sh) interface not required
Registration in IMS domain	5.1	6.2	6.3	HRPD processing excluded (WLAN only) 3GPP2-UE not required to indicate its capabilities 3GPP2-UE not required to re-register when it detects IP-CAN capabilities are different
Registration in CS domain	5.2		-	PacketCable adds optional support for ANSI-41 Registration Notifications (WIN LBS standard)
Registration - other	5.3		6.3	Use of SMS (to report loss of IMS coverage) not required
Distinguish incoming SIP requests	-	-	7.4.1, 8.4.1, 9.3.1, 10.4.1	Use of configurable domain-transfer digits
IMS call origination	6.1	7.2	7.4.2	None
CS call origination	6.2		7.4.3 7.4.4	PacketCable suggests avoidance of extraneous SIP INVITE back to VCC AS Support for WIN based solution (Stage 2, Sec. 6.2.1) required / Support for pre-WIN based solution (Stage 2, Sec. 6.2.2) not required
Call termination– DN homed in IMS domain	7.1 7.2	8.2	8.4.2	None
Call termination - DN homed in CS domain	7.3 7.4		8.4.3 8.4.4	Out-of-scope for PacketCable
Domain transfer - IMS to CS	8 9	10.2	10.4.2 10.4.3	HRPD processing (Stage 2, Sec. 8) excluded (WLAN only) Use of configurable domain-transfer digits (i.e., VDN) Support for WIN based solution (Stage 2, Sec. 9.2) required / Support for non-trigger based solution (Stage 2, Sec. 9.1) not required
Domain transfer - CS to IMS	10	9.2	9.3.2	Use of configurable domain-transfer digits (i.e., VDI)
Supplementary Services	11	-	-	Superseded by PacketCable service requirements

Appendix IV Out of Scope Items

The following items are not defined and out of scope in the present release of the PacketCable cellular integration specification.

The gsmSCF is likely to be located in the mobile network, rather than integrated in the 3GPP VCC AS. The gsmSCF to 3GPP VCC AS interface is identified in 3GPP, but not standardized. So unless the 3GPP VCC AS can interface directly to the VMSC CAMEL interface as shown in this specification, the 3GPP VCC application server will include an undefined cellular interface.

Provisioning and configuration items are out of scope of this release,

Charging data for VCC is out of scope of this release.

Digit map aspects for non black phones, such as dual-mode handsets, are out scope of this release.

The Centralized Telephony Service Model is being standardized in 3GPP. This telephony execution model has advantages for the Cable Operator and should be considered for inclusion in this specification once available. The Centralized Telephony Service Model is out of scope of this release.

The cellular transport mechanism for user determined feature data from the UE in the CS domain to the PacketCable AS is out of scope of this release.

The cellular transport mechanism for MWI between the PacketCable AS and the UE in the CD domain is out of scope of this release.

Mandatory codec support for PacketCable via WiFi is not identified for this release.

The use of dynamic VDI/VDN assignments, considered an optimization for VCC implementation is out of scope for this release.

Voice call continuity for E911 calls is out of scope for this release.

Mandatory security mechanisms are not identified in this release.

A mechanism for the correct UE location determination and conveyance for E911 calls over WiFi in the presence of a home network NAT and Firewall is out of scope of this release.

A PacketCable application for operator services with the dual-mode handset is out of scope of this release. (Handsets are not expected to support the media mixing defined in RST operator services).

Appendix V Acknowledgements

We wish to thank the vendor participants and CableLabs staff contributing directly to this document:

Justin Aborn - Bridgeport Networks

Jay Bestermann - Arris

Tarun Chugh - Arris

Russ Coffin - Nortel

Rex Coldren - Alcatel-Lucent

Steffen Engmann - Siemens

Tom Hallin - Motorola

Nermeen Ishmail - Cisco

Gordon Li - Broadcom

Don Lukacs - Telcordia

Satish Kumar - TI

Mark Trayer - Samsung

Eric Turcotte - Ericsson

Lee Valerius - Nortel

David Walker - NewStep

Steve Dotson - CableLabs

Sumanth Channabasappa - CableLabs

Bernie McKibben and the PacketCable Architecture team, CableLabs
