

Superseded **by a later version of this document**

PacketCable™ 1.5 Specifications

Embedded MTA Analog Interface and Powering

PKT-SP-AIP1.5-I01-050128

ISSUED

Notice

This specification is a cooperative effort undertaken at the direction of Cable Television Laboratories, Inc. (CableLabs®) for the benefit of the cable industry. Neither CableLabs, nor any other entity participating in the creation of this document, is responsible for any liability of any nature whatsoever resulting from or arising out of use or reliance upon this document by any party. This document is furnished on an AS-IS basis and neither CableLabs, nor other participating entity, provides any representation or warranty, express or implied, regarding its accuracy, completeness, or fitness for a particular purpose.

© Copyright 2004-2005 Cable Television Laboratories, Inc.
All rights reserved.

Document Status Sheet

Document Control Number:	PKT-SP-AIP1.5-I01-050128			
Document Title:	Embedded MTA Analog Interface and Powering			
Revision History:	D01 – Released September 30, 2004			
	I01 – Issued January 28, 2005			
Date:	January 28, 2005			
Status:	Work in Progress	Draft	Issued	Closed
Distribution Restrictions:	Author Only	CL Member	CL Member/ Vendor	Public

Key to Document Status Codes:

- Work in Progress** An incomplete document, designed to guide discussion and generate feedback, that may include several alternative requirements for consideration.
- Draft** A document in specification format considered largely complete, but lacking review by Members and vendors. Drafts are susceptible to substantial change during the review process.
- Issued** A stable document, which has undergone rigorous member and vendor review and is suitable for product design and development, cross-vendor interoperability, and for certification testing.
- Closed** A static document, reviewed, tested, validated, and closed to further engineering change requests to the specification through CableLabs.

TRADE MARKS:

DOCSIS®, eDOCSIS™, PacketCable™, CableHome®, CableOffice™, OpenCable™, CableCARD™ and CableLabs® are trademarks of Cable Television Laboratories, Inc.

Contents

1	INTRODUCTION	1
1.1	Purpose	1
1.2	Scope.....	1
1.3	Motivation	1
1.4	Document Overview.....	2
1.5	Requirements Syntax.....	2
2	REFERENCES	3
2.1	Normative.....	3
2.2	Informative	3
2.3	Reference Acquisition	3
3	TERMS AND DEFINITIONS.....	4
4	ABBREVIATIONS AND ACRONYMS	4
5	INTRODUCTION	6
5.1	PacketCable Overview	6
5.2	Service Goals.....	6
5.3	PacketCable Reference Architecture	6
5.3.1	Multimedia Terminal Adapter (MTA).....	7
5.4	PacketCable Specifications.....	8
5.5	E-MTA Alarms.....	8
5.5.1	CM Failures	9
5.5.2	MTA Failures	9
5.6	E-MTA Telemetry	9
5.6.1	Telemetry Signals (External Interface)	9
5.6.2	OSS Event Reporting	10
6	E-MTA POWER REQUIREMENTS	11
6.1	Power Considerations	11
6.2	Typical E-MTA Traffic Model	11
6.3	Power Passing Tap Limitations	12
6.4	Average Power Calculations	12
6.5	Power Factor Considerations	12
6.6	E-MTA Average Power Requirements	13
6.7	Service Requirements Under AC Fail Conditions	13
6.8	Power Source Compatibility.....	13
6.9	Network Powering	13
6.9.1	Center Conductor Delivery	13

6.9.2	Composite Pair Delivery	13
6.9.3	Network Power Characteristics	14
6.10	Local Powering with Battery Backup	14
6.10.1	E-MTA to UPS Interface	14
7	MTA ANALOG PORT REQUIREMENTS	15
7.1	Loop Start Signaling	15
7.1.1	DC Supervisory Range	15
7.1.2	Idle State Voltage	16
7.1.3	Loop Closure Detection	16
7.1.4	Loop Open Detection.....	16
7.1.5	Off-Hook Delay	16
7.1.6	On-Hook Delay	17
7.1.7	Ringsplash.....	17
7.1.8	Distinctive Ringing	17
7.1.9	Transmission Path.....	17
7.2	General Supervision	17
7.2.1	Off-Hook Loop Current	17
7.2.2	Immunity to Line Crosses	17
7.2.3	System Generated Open Intervals	17
7.2.4	Open Switching Interval Distortion	18
7.2.5	Dial Pulsing.....	18
7.2.6	DTMF Signaling.....	18
7.2.7	Dialtone Removal	18
7.3	General Ringing.....	19
7.3.1	Alerting Signals.....	19
7.3.2	Ringling Delay	19
7.3.3	Ringling Source	19
7.3.4	Ringling Capability.....	19
7.3.5	Ringling Capacity	20
7.3.6	Ring Trip.....	20
7.3.7	Ring Trip Reporting Delay	20
7.3.8	Ring Trip Immunity	20
7.4	Voice Grade Analog Transmission.....	20
7.4.1	Input Impedance	21
7.4.2	Hybrid Balance	21
7.4.3	Longitudinal Balance	21
7.4.4	MTA Loss	21
7.4.5	MTA Loss Tolerance	21
7.4.6	Frequency Response	22
7.4.7	60 Hz Loss.....	22
7.4.8	Amplitude Tracking.....	22
7.4.9	Overload Compression.....	22
7.4.10	Idle Channel Noise	22
7.4.11	Signal to Distortion	23
7.4.12	Impulse Noise	23
7.4.13	Intermodulation Distortion.....	23
7.4.14	Single Frequency Distortion	23
7.4.15	Generated Tones.....	23

7.4.16 Peak-to-Average Ratio	23
7.4.17 Channel Crosstalk	24

List of Figures

Figure 1. Transparent IP Traffic Through the Data-Over-Cable System..... 6
Figure 2. PacketCable Reference Architecture..... 7
Figure 3. E-MTA..... 8

List of Tables

Table 1. E-MTA Traffic Model 11
Table 2. Input Voltage Ranges for E-MTAs without embedded UPS functionality..... 14

Superseded

1 INTRODUCTION
by a later version of this document

1.1 Purpose

This specification defines the embedded MTA (E-MTA) requirements for the analog interface and for powering of the E-MTA. An embedded MTA is a DOCSIS cable modem (CM) integrated with a PacketCable multimedia terminal adapter (MTA).

The purpose of this specification is to define a set of requirements that will enable a service that is sufficiently reliable to meet an assumed consumer expectation of essentially constant availability, including, specifically, availability during power failure at the customer's premises, and (assuming the service is used to connect to the PSTN), access to emergency services (911, etc.).

1.2 Scope

This document covers requirements for the E-MTA analog interface and for powering of the E-MTA. It is the intention of this document to address requirements only for the E-MTA. See section 5.3.1 for a complete description of the E-MTA.

To enable a service that meets the assumed customer expectations described in section 1.1, three E-MTA interfaces have been identified: (1) powering the E-MTA, (2) telemetry support, and (3) the analog POTS interface.

Powering the E-MTA is critical for the service to function during periods when utility power fails. Consequently, the power consumption characteristics of the E-MTA will enable service providers to offer alternate powering techniques.

Telemetry support enables the service provider to remotely monitor the status of the E-MTA. The first application of telemetry enables remote monitoring of the E-MTA power source.

The analog POTS interface requirements ensure that CPE that meets telephone industry interoperability requirements (normal telephones, answering machines, etc.) will also operate in the PacketCable environment. Note that the voice-grade analog transmission requirements are dependent on the compression algorithm utilized to transport the packetized voice signal in the PacketCable architecture. These requirements are derived from existing PSTN requirements that are based on a full 64 kbps voice channel. Therefore, the requirements specified are relevant only for the G.711 audio codec. Other audio codec compression algorithms specified by PacketCable [2] are not addressed in this specification.

Note also that the telemetry interface specified in this document is between the E-MTA and an external local un-interruptible power supply (UPS). The UPS itself is not within the scope of this document, so specific requirements for the UPS are not included here. Nonetheless, requirements for the E-MTA telemetry interface may have certain design implications on the UPS.

1.3 Motivation

PacketCable interface specifications define a system architecture to allow vendors to develop interoperable equipment capable of providing packet-based voice, video and other high-speed multimedia services over hybrid fiber coax (HFC) cable systems utilizing the DOCSIS protocol. IP-based voice telephony services are one possible service application.

From time to time this document refers to the voice communications capabilities of a PacketCable network in terms of “IP Telephony.” The legal/regulatory classification of IP-based voice communications provided over cable networks and otherwise, and the legal/regulatory obligations, if any, borne by providers of such voice communications, are not yet fully defined by appropriate legal and regulatory authorities. Nothing in this specification is addressed to, or intended to affect, those issues. In particular, while this document uses standard terms such as “call,” “call signaling,” “telephony,” etc., it should be recalled that, while a PacketCable network performs activities analogous to these PSTN functions, the manner by which it does so differs considerably from the manner in which they are performed in the PSTN by telecommunications carriers, and that these differences may be significant for legal/regulatory purposes. Moreover, while reference is made here to “IP Telephony,” it should be recognized that this term embraces a number of different technologies and network architecture, each with different potential associated legal/regulatory obligations. No particular legal/regulatory consequences are assumed or implied by the use of this term.

1.4 Document Overview

This specification is organized as follows:

Section 5 presents an overview of the PacketCable reference architecture.

Section 6 defines the powering requirements of the E-MTA.

Section 7 defines the analog port (POTS) requirements of the E-MTA.

1.5 Requirements Syntax

Throughout this document, the words that are used to define the significance of particular requirements are capitalized. These words are:

“MUST”	This word or the adjective “REQUIRED” means that the item is an absolute requirement of this specification.
“MUST NOT”	This phrase means that the item is an absolute prohibition of this specification.
“SHOULD”	This word or the adjective “RECOMMENDED” means that there may exist valid reasons in particular circumstances to ignore this item, but the full implications should be understood and the case carefully weighed before choosing a different course.
“SHOULD NOT”	This phrase means that there may exist valid reasons in particular circumstances when the listed behavior is acceptable or even useful, but the full implications should be understood and the case carefully weighed before implementing any behavior described with this label.
“MAY”	This word or the adjective “OPTIONAL” means that this item is truly optional. One vendor may choose to include the item because a particular marketplace requires it or because it enhances the product, for example; another vendor may omit the same item.

2 REFERENCES

2.1 Normative

- [1] PacketCable 1.5 Network-Based Call Signaling Protocol Specification, PKT-SP-NCS1.5-I01-050128, January 28, 2005
- [2] PacketCable 1.5 Audio/Video Codecs Specification, PKT-SP-CODEC1.5-I01-050128, January 28, 2005.
- [3] DOCSIS Radio Frequency Interface Specification, SP-RFIV1.1-I10-030730, July 30, 2003, Cable Television Laboratories, Inc.
- [4] DOCSIS Operations Support System Interface Specification, SP-OSSIV1.1-I07-030730, July 30, 2003, Cable Television Laboratories, Inc.
- [5] Telcordia (Bellcore) GR-499-CORE, Issue 2, December 1998, Transport Systems Generic Requirements (TSGR): Common Requirements.
- [6] Telcordia (Bellcore) TR-NWT-000303, Issue 2, December 1992, Integrated Digital Loop Carrier System Generic Requirements, Objectives, and Interface.
- [7] Telcordia (Bellcore) GR-1089-CORE, Issue 2, December 1997, update rev 01, February 1999, Generic Requirements for Electronic Equipment Cabinets, Electromagnetic Compatibility and Electrical Safety Generic Criteria for Network Telecommunications Equipment.
- [8] Telcordia (Bellcore) TA-NWT-000909, Issue 2, December 1993, Generic Requirements and Objectives for Fiber in the Loop (FITL) Systems.
- [9] Telcordia (Bellcore) GR-517-CORE, Issue 1, December 1998, LEC Traffic Environment Characteristics.
- [10] PacketCable 1.5 Management Event Mechanism, PKT-SP-MEM1.5-I01-050128, January 28, 2005.

2.2 Informative

- [11] PacketCable 1.5 Architecture Framework, PKT-TR-ARCH1.5-V01-050128, January 28, 2005
- [12] DOCSIS Cable Modem to Customer Premise Equipment Interface Specification, SP-CMCI-I09-030730, July 30, 2003, Cable Television Laboratories, Inc.
- [13] P. Key and D. Smith (editors). 1999. The Internet & The Public Switched Telephone Network – A Troubled Marriage. In *Teletraffic Engineering in a Competitive World*. Edinberg: Elsevier.

2.3 Reference Acquisition

- Cable Television Laboratories, Inc., 858 Coal Creek Circle, Louisville, CO 80027; Phone 303-661-9100; Fax 303-661-9199; Internet: www.packetcable.com/ or www.cablemodem.com.
- Telcordia Technologies, Inc., 8 Corporate Place, PYA 3A-184, Piscataway, NJ 08854-4156, 1.800.521.2673, +1.732.336.2559, <http://telecom-info.telcordia.com>

3 TERMS AND DEFINITIONS

This document uses the following terms:

- Bellcore (Telcordia)** PSTN research/standards organization.
Telcordia (Bellcore) PSTN research/standards organization.

4 ABBREVIATIONS AND ACRONYMS

This document uses the following abbreviations:

A/D	Analog to Digital converter.
CM	Cable Modem.
CMCI	Cable Modem Customer premise Interface.
CMS	Call Management Server.
CMTS-NSI	CMTS- Network Side Interface.
CPE	Customer Premise Equipment. Usage of CPE within this specification generically refers to the cable modem and MTA device that reside at the subscriber home, as well as any customer telephony equipment (telephones, answering machines, fax machines, etc.). Typically, CPE would refer to equipment that is beyond the service provider network interface, such as a telephone or personal computer. However, since the cable modem/MTA represent the service provider network interface device at the subscriber home, it is commonly referred to as CPE.
DOCSIS®	Data Over Cable System Interface Specification.
FITL	Fiber In The Loop. A PSTN architecture consisting of a fiber optic access network.
HDT	Host Digital Terminal. PSTN term for headend equipment providing access network distribution.
HFC	Hybrid Fiber Coax. Access network architecture consisting of fiber optic feeders from the headend to nodes, at which point coaxial cable is used for the final distribution to the subscribers.
IP	Internet Protocol. A network layer protocol.
LEC, ILEC, CLEC	Local Exchange Carrier. Incumbent LEC and Competitive LEC. A PSTN service provider.
MGC	Media Gateway Controller. The control element of a PSTN gateway.
MSO	Multi-System Operator, a cable company that operates many head-end locations in several cities.
MTA, MTA-1	Multimedia Terminal Adapter. An MTA-1 is a PacketCable client that can be attached to a CM (standalone) or integrated with a CM (embedded) that supports POTS.
NCS	Network Call Signaling. The PacketCable MGCP profile used for controlling calls.
NI, NID	Network Interface or Network Interface Device. A common PSTN term, also used by PacketCable, that refers to the subscriber's interface point to the

	network. In this document, the E-MTA is considered the NI or NID.
ONU	Optical Network Unit. Equivalent to a E-MTA in the FITL architecture.
OSS	Operations Support System.
POTS	Plain Old Telephone Service.
PSTN	Public Switched Telephone Network.
SNMP	Simple Network Management Protocol.
UPS	Uninterruptible Power Supply. A power supply including a battery for backup power when AC input power fails.

5 INTRODUCTION

5.1 PacketCable Overview

PacketCable is a project conducted by Cable Television Laboratories, Inc. (CableLabs®) and its member companies. The PacketCable project is aimed at defining interface specifications that can be used to develop interoperable equipment capable of providing packet-based voice, video and other high-speed multimedia services over hybrid fiber coax (HFC) cable systems utilizing the Data Over Cable Interface Specification (DOCSIS) [3].

5.2 Service Goals

One potential application of the PacketCable architecture is packet-based voice communications for cable system subscribers. The PacketCable architecture as a whole enables voice communications, video, and data services based on bi-directional transfer of Internet protocol (IP) traffic between the cable system headend and customer locations, over an all-coaxial or HFC cable network as shown in simplified form in Figure 1.

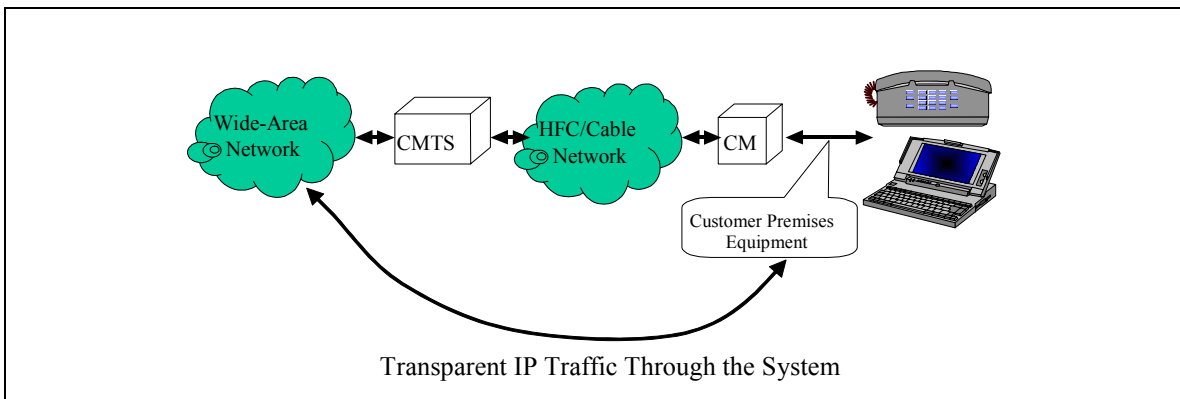

Figure 1. Transparent IP Traffic Through the Data-Over-Cable System

The transmission path over the cable system is realized at the headend by a cable modem termination system (CMTS), and at each customer location by a cable modem (CM). At customer locations, the interface is called the cable-modem-to-customer-premises-equipment interface (CMCI) and is specified in [12].

5.3 PacketCable Reference Architecture

The PacketCable architecture is composed of three distinct component networks: the “DOCSIS HFC Access Network”, the “Managed IP Network” and the PSTN. The Cable Modem Termination System (CMTS) provides connectivity between the “DOCSIS HFC Access Network” and the “Managed IP Network”. Both the Signaling Gateway (SG) and the Media Gateway (MG) provide connectivity between the “Managed IP Network” and the PSTN. The reference architecture for PacketCable is shown in Figure 2 and is further described in [11].

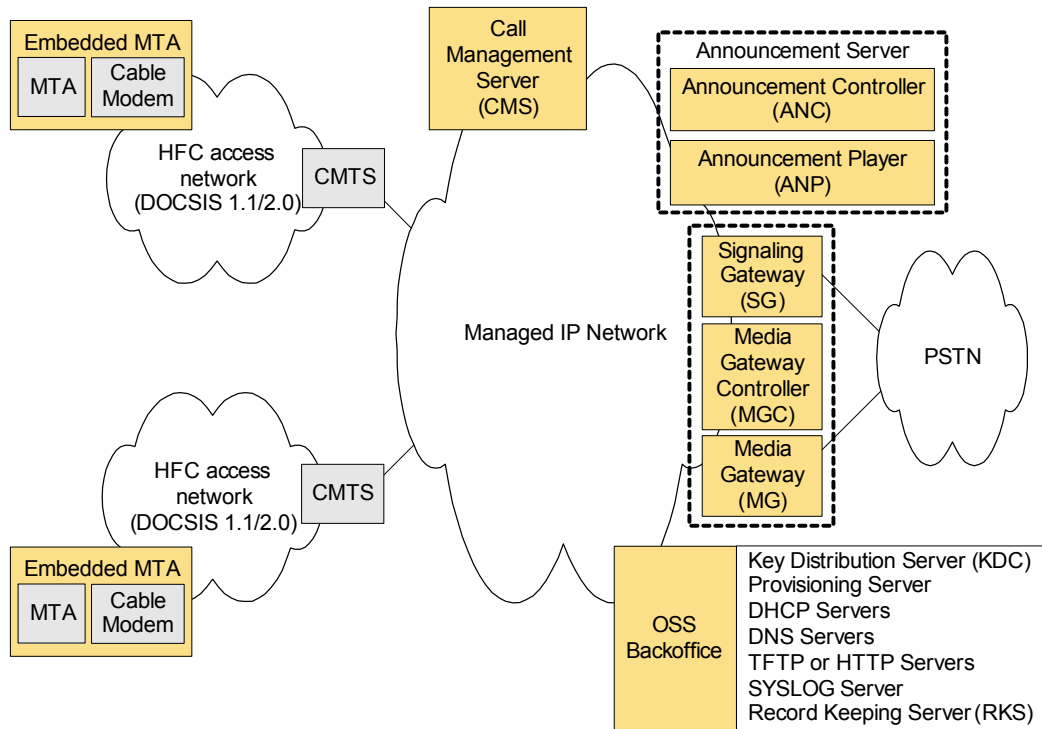

Figure 2. PacketCable Reference Architecture

The DOCSIS HFC access network provides high-speed, reliable, and secure transport between the customer premise and the cable headend. This access network provides all DOCSIS 1.1/2.0 capabilities including Quality of Service. The DOCSIS HFC access network includes the following functional components: the Cable Modem (CM), Multi-media Terminal Adapter (MTA), and the Cable Modem Termination System (CMTS).

The Managed IP network serves several functions. First, it provides interconnection between the basic PacketCable functional components responsible for signaling, media, provisioning, and quality of service establishment. In addition, the managed IP network provides long-haul IP connectivity between other Managed IP and DOCSIS HFC networks. The Managed IP network includes the following functional components: Call Management Server (CMS), Announcement Server (ANS), several Operational Support System (OSS) back-office servers, Signaling Gateway (SG), Media Gateway (MG), and Media Gateway Controller (MGC).

The public switched telephone network (PSTN) gateway provides access from the subscriber network into the PSTN network. The OSS back office provides support services such as billing, provisioning, fault determination, problem resolution, and other support services.

5.3.1 Multimedia Terminal Adapter (MTA)

An MTA is a PacketCable client device that contains a subscriber-side interface to the subscriber's CPE (e.g., telephone) and a network-side signaling interface to call control elements in the network (e.g., Call Management Server (CMS)). An MTA provides codecs and all signaling and encapsulation functions required for media transport and call signaling.

MTAs reside at the customer site and are connected to other PacketCable network elements via the HFC access network (DOCSIS). PacketCable MTAs are required to support the Network Call Signaling (NCS) protocol.

PacketCable only defines support for an embedded MTA (E-MTA). An E-MTA is a single hardware device that incorporates a DOCSIS 1.1 or 2.0 CM as well as a PacketCable MTA component. Figure 3 shows a representative functional diagram of an embedded MTA. Additional MTA functionality and requirements are further defined in [11]. For the purposes of this specification, MTA is interpreted to be identical to E-MTA.

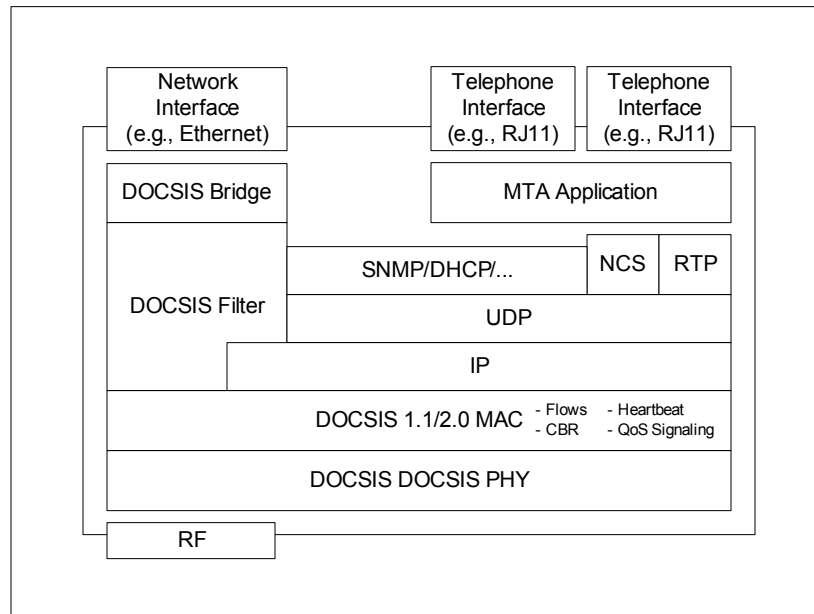

Figure 3. E-MTA

5.4 PacketCable Specifications

The PacketCable architecture is defined by a set of Specifications and Technical Reports. Refer to [11] for more information. E-MTA Monitoring Requirements

The E-MTA is a critical element in the PacketCable architecture. It provides the customer's interface to the service provider's network and is located outside the service provider's "headend". As such, it is critical that the operational status of the E-MTA be monitored in order to provide the quickest information to the service provider. This section details the critical monitoring requirements of the E-MTA.

5.5 E-MTA Alarms

The E-MTA functions as the customer premise network interface to the PacketCable network and thus enables service to the customer. If the E-MTA fails and is not capable of providing the intended service, the service provider will need to know about this condition quickly (and preferably before the customer).

The minimum goal of fault management should be to isolate failures to a field replaceable unit. This enables the service provider to confidently dispatch service personnel with the appropriate equipment necessary to repair the problem in the least amount of time (i.e., minimize Mean Time To Replacement, or MTTR). The E-MTA can be considered a field replaceable unit since it is embedded, or integrated, with the CM.

5.5.1 CM Failures

The CM provides the critical connection between the MTA and the PacketCable/DOCSIS network. A CM failure will affect the availability of the service.

PacketCable service will rely on the CM failure detection mechanisms defined by DOCSIS in [4]. DOCSIS specifies events that the CM must detect as well as events the CMTS must detect.

5.5.2 MTA Failures

The minimum MTA monitoring **MUST** utilize the CM failure detection mechanisms defined by DOCSIS [4] since the CM and MTA are integrated together.

Additional MTA monitoring mechanisms **MAY** be developed but are not defined in this document. For example, the E-MTA may include internal on-line diagnostics utilized to detect vendor specific events.

5.6 E-MTA Telemetry

The telemetry feature provides the ability for the E-MTA to transmit alarm information to the headend. The alarm information could reflect status of the E-MTA itself or of a supporting device connected to the E-MTA. Refer to [10] for information on the set of defined alarms.

One powering option of the E-MTA is local power with uninterruptible power supply (UPS) battery backup. Maintaining constant power at the E-MTA is important to providing reliable service. For example, an operator may want the service to continue to function when the commercial utility power fails at the subscriber home. Thus, an alternate power source is required to bridge the gaps when utility power is not available.

The telemetry feature specified in [10] and required here is initially intended for UPS battery alarms. However, the UPS powering option of the E-MTA may not always be used. As such, the design allows enough flexibility for the telemetry feature to be utilized for other purposes. This section will define the specific UPS battery alarm usage. Other usage of telemetry is not defined and is outside the scope of this document.

The UPS may be a separate, external device connected to the E-MTA or an internal device, integrated with the E-MTA. The physical telemetry interface defined in this document is for the external UPS device. An internal UPS is not required to support the same physical interface.

5.6.1 Telemetry Signals (External Interface)

The E-MTA alarm telemetry input signals **MUST** determine the input state by sensing the presence of a short circuit to ground (low) or an open circuit condition (float high) on the input connection (open drain compatible). The alarm active state is defined as the open circuit condition (float high). The alarm inactive state is defined as the short circuit to ground (low).

A telemetry common signal separate from the 48VDC return signal **MUST** be provided. Since the E-MTA power supply input is required to support AC network power, both of the power supply input pins will be floating with respect to ground. Therefore, a separate telemetry common signal is required to establish a common ground reference between the E-MTA and UPS.

Note that this interface forces the external device to “actively” control the signal states. In other words, the device must actively short the signal to ground to signal an inactive alarm state and must actively open the circuit to float high to signal an active alarm state. This provides a fail-safe mechanism such that if any or all of the signals become disconnected from the E-MTA, they will float high and thus indicate an active alarm condition. For example, it is not valid for all 4 UPS alarms to be active at the same time (cannot

operate off battery if a battery is not present). Therefore, if such a condition is detected, it is possible to deduce that the UPS has become disconnected from the E-MTA.

5.6.1.1 Telemetry Signal 1 – AC Fail

The active alarm state of this signal indicates an “AC Fail” condition, which means the UPS, has detected a failure of the utility AC power and is operating off its battery.

The inactive alarm state of this signal indicates an “AC Restored” condition which means the UPS has detected the presence of utility AC power and is no longer operating off its battery.

5.6.1.2 Telemetry Signal 2 – Replace Battery

The active alarm state of this signal indicates a “Replace Battery” condition which means the UPS, via internal test mechanisms outside the scope of this document, has determined that the battery can no longer maintain a charge sufficient enough to provide the designed amount of battery backup (e.g. 8 hours of battery backup) and thus is failing and should be replaced with a new battery.

The inactive alarm state of this signal indicates a “Battery Good” condition.

5.6.1.3 Telemetry Signal 3 – Battery Missing

The active alarm state of this signal indicates a “Battery Missing” condition, which means the UPS, has detected that a battery is not present and a battery should be installed in the UPS.

The inactive alarm state of this signal indicates a “Battery Present” condition.

5.6.1.4 Telemetry Signal – Battery Low

The active alarm state of this signal indicates a “Battery Low” condition which means the battery has sufficiently discharged (e.g., 75% discharged) to the point where a power source can only be maintained for a short while longer.

The inactive alarm state of this signal indicates a “Battery Not Low” condition which means the battery has charged above the “battery low” threshold (e.g. at least 25% charged).

5.6.2 OSS Event Reporting

The MTA MUST support the event and alarm reporting mechanism as defined in [10]. Furthermore, the MTA MUST support the Powering events as defined in [10].

6 E-MTA POWER REQUIREMENTS

This section defines the power requirements of the E-MTA. This includes power consumption and presents associated traffic models recommended for power consumption calculations.

6.1 Power Considerations

E-MTA powering is an important element in providing reliable telephone service through HFC cable networks. There are two basic methods to power the E-MTA: (1) local with battery backup and (2) network powering. Local power refers to utilizing the subscriber's home AC utility power as the supply for the E-MTA. A battery backup is utilized when the utility power fails. Network power refers to utilizing power supplied by the service provider via their HFC cable network.

A key consideration in HFC power system design is maintaining power to the E-MTA even when local AC power has failed. In general, the power system should provide a E-MTA with sufficient backup power (to accommodate typical power outages) for a typical E-MTA traffic model. This creates constraints on power consumption for locally powered systems that provide battery backup. A E-MTAs average power consumption directly affects the size and cost of the backup batteries.

Although network power centralizes backup power reserves, E-MTA power consumption nevertheless directly affects the cost and size of a power node. In addition, in network-powered systems, other conditions exist that limit the amount of power that can be delivered to an E-MTA (e.g., a coaxial power passing tap).

6.2 Typical E-MTA Traffic Model

A projected "typical" E-MTA traffic model has been developed based on [9] and [13] and input from member operators. As the PacketCable architecture is actually deployed in the field, and as consumer demand for services using that architecture continues to evolve, individual operators with actual PacketCable implementations may experience significantly different traffic characteristics. With this qualification, this model may be used to calculate long term average power.

Table 1. E-MTA Traffic Model

Line Number	MTA Line 1	MTA Line 2	MTA Line 3	MTA Line 4	Cable Modem Data
Assumed Use	Voice	Modem/ Voice	Voice/ Fax	Voice	High Speed Data
CCS	4	4	2	2	4
Line Penetration (Normalized by Penetration)	100%	80%	50%	25%	25%
Average Ringing Period	14 sec	14 sec	14 sec	14 sec	n/a
Average call length					
E-MTA w/o Data Service	5 min	26 min	5 min	5 min	n/a
E-MTA with Data Service	5 min	5 min	5 min	5 min	n/a
Average Data Rate to Subscriber*	n/a	n/a	n/a	n/a	100kb/s
Average Data Rate From Subscriber*	n/a	n/a	n/a	n/a	10kb/s

The average cable modem data rates shown in column 5 of Table 2 assume that when a user is active on the system (i.e., 4CCS), the user is interpreting or typing information during 90% of the active session, and no significant data is flowing through the data interface. Data interface rates of 1Mb/s to the subscriber and 100kb/s from the subscriber are assumed during the remaining 10% of the session. The averages are assumed to be long term and are considered over the entire domain of a power node (i.e., 100's of E-MTAs).

6.3 Power Passing Tap Limitations

Power passing taps typically have a maximum continuous current rating that specifies limits on the amount of current that can be supplied to a particular "drop" off of the network (the drop is the section of coax connecting the operator network to the subscriber's home). Power passing taps typically contain a self-resetting protection device that is rated at 350mA of continuous current. Also, the network power voltage can vary between 40VACrms and 90VACrms at the subscriber interface. Therefore, in the worst case at 40VAC, the maximum continuous power that can be supplied to a network device on the drop is about 14VArms (Volt-Amps = watts/power factor) before the self-resetting protection device of the power passing tap activates.

PacketCable network-powered E-MTAs SHOULD NOT exceed 14VArms power consumption in any continuous mode of operation. Furthermore, network-powered E-MTAs MUST limit input current to less than 350mA in any continuous mode of operation for input voltages in the range 0-90VACrms. Continuous mode of operation refers to any sustained mode that would draw more than 14 VArms and thus, potentially cause the power passing tap protection device to activate. For example, all lines off-hook with data traffic running at maximum average throughput for the device under consideration would be considered a sustained, continuous mode of operation while cadence ringing would not. In general, higher ringing currents can be tolerated due to the slow reacting nature of the self-resetting protection device.

6.4 Average Power Calculations

For network-powered systems, E-MTA power is also limited by the total power available from the power node and the required number of E-MTAs to be supported from each node. Because a common power source is being utilized to power a large number of E-MTAs, long term average E-MTA power can be utilized for power node calculations instead of maximum E-MTA power. Since E-MTAs will operate in various modes (on-hook, off-hook, ringing, etc.), a statistical traffic model (such as CCS numbers) can be used to characterize long term average E-MTA power and furthermore the number of E-MTAs that can be supported in a particular power node domain can be calculated.

For local powered systems with battery backup, long-term average E-MTA power can be utilized to determine the typical battery backup time for a particular E-MTA and UPS combination. By dividing the battery's effective watt-hour rating by the E-MTAs average power rating, and taking into account power conversion and wire I-R loss effects, the typical battery-backed operation time can be determined.

6.5 Power Factor Considerations

Since network power utilizes alternating current (AC), the power factor of a device also affects a node's power calculation. Power factor specifies the ratio of watts to volt-amperes.

The PacketCable power factor of an E-MTA device SHOULD be 0.85 or greater to ensure efficient utilization of the available network power.

To stress that power factor must be accounted for in E-MTAs, power figures MUST be specified in terms of Volt-Amp (VA) rather than Watts (W).

6.6 E-MTA Average Power Requirements

Since many different HFC power node domain architectures exist, it is not possible to calculate an E-MTA average power requirement that relates to all architectures. Nonetheless, several common power consumption objectives have been specified to enable efficient powering capabilities.

The average E-MTA power consumption SHOULD be less than or equal to 5 VA when applying the traffic model above. The average power consumption refers to the typical long-term average consumption of the device and is intended to provide a reference for designing the power node architecture.

6.7 Service Requirements Under AC Fail Conditions

For local power with battery backup, the E-MTA device is aware of AC power failure via the UPS telemetry inputs or via internal means with an embedded UPS. Since data traffic is not required for PacketCable service, data service MAY be de-activated immediately under local AC power fail conditions. However, all lines provided by an E-MTA MUST remain operational (operational means capable of originating calls, ringing, and terminating calls, if provisioned as in-service).

6.8 Power Source Compatibility

To provide flexibility to make powering decisions on a node-by-node basis and to allow local power to network power migration, outdoor E-MTAs MUST support both network power and local power with battery backup (as defined below). Since network powering is removed from the coax drop before entering the home, indoor E-MTAs MUST support local powering with battery backup and are not required to support network power.

6.9 Network Powering

Network power is supplied from a power node controlled by the service provider and is distributed through the HFC plant via the network cable. It is common practice for Network power to be delivered from the “tap” to the E-MTA either through center conductor powering (center coax conductor) or through composite pair (siamese pair) powering.

6.9.1 Center Conductor Delivery

Center conductor network power delivers power on the center conductor of the coaxial cable drop. Outdoor E-MTAs MUST be capable of extracting power from the center conductor of the coaxial cable. If an E-MTA provides a subscriber side coaxial drop, network power MUST be removed from the subscriber drop such that network power does not enter the customer premise. If an E-MTA provides a subscriber side coaxial drop, greater than 60 dB of Isolation MUST be provided at 60 Hz, 120 Hz, 180 Hz, and 240 Hz between the network side coaxial drop and the subscriber side coaxial drop. To prevent the introduction of “AC HUM” into the coexisting RF signals, for an E-MTA that provides a subscriber side coaxial drop, the E-MTA MUST NOT degrade Hum Modulation more than 3% toward the subscriber side drop.

In center conductor network power mode, the composite pair power terminals MUST NOT present a shock hazard.

6.9.2 Composite Pair Delivery

Composite pair network power delivers power on a separate pair of wires that are bundled with the coaxial cable drop (siamese) from the tap. E-MTAs MUST be capable of accepting power through a separate pair of input terminals. The power-input terminals MUST be compatible with 22, 24, and 26-gauge wire. The power-input terminals MAY also be compatible with any other gauge wire.

6.9.3 Network Power Characteristics

E-MTAs supporting network power **MUST** be compatible with and properly operate from quasi-square wave voltages over the range 40-90VAC at the input of the device.

6.10 Local Powering with Battery Backup

Local powering is accomplished utilizing a UPS that converts household 120V AC power to DC power for the E-MTA. The UPS also provides battery backup to bridge E-MTA operation through typical local power outages. In addition, telemetry signals provide remote monitoring capability for local AC power and battery conditions. Outdoor E-MTA devices will typically utilize a separate UPS such that batteries can be placed inside the customer's facility. The indoor climate controlled environment is typically desired for battery placement to maximize battery life. E-MTAs utilizing an external UPS will require metallic connections between the two units for transmission of power and telemetry information. E-MTAs **MAY** include an embedded UPS or utilize an external UPS.

6.10.1 E-MTA to UPS Interface

A standardized interface is defined between the E-MTA and an external UPS to allow vendor interoperability between the two devices. This interface is comprised of seven (7) conductors including two (2) for DC power, four (4) for telemetry signals, and one (1) for telemetry ground reference. The external E-MTA-UPS interface **MUST** be included on E-MTA implementations that do not provide embedded UPS functionality. For E-MTAs with embedded UPS functionality, there is no requirement to provide the physical E-MTA-UPS interface signals externally, however, the embedded telemetry information **MUST** still be made available to upstream network management systems as defined in Section 5.6.

6.10.1.1 Physical Connection

Since the interface cable between the E-MTA and UPS will typically be cut to length, the E-MTA **SHOULD** provide individual connections for each conductor but **MAY** utilize a standard multi-pin connector. The specific type of connection device will not be specified, however the connection device **MUST** support 22, 24, and 26-gauge wire. The connection device **MAY** also support any other gauge wire.

6.10.1.2 Power Signals (External UPS)

The power interface is designed to provide 20 watts of peak power to the E-MTA which provides ample power for E-MTA implementations supporting a high speed data link and up to 4 telephony lines with a total ringing load of 10 REN. To enable the use of 22-26-gauge wire for the interface, 48VDC nominal power is being required.

The E-MTA without embedded UPS functionality **MUST** support the following input voltage range:

Table 2. Input Voltage Ranges for E-MTAs without embedded UPS functionality

Signal	Value
Power	+48VDC nominal, +42VDC min, +51VDC max
Power return	48VDC Return

7 MTA ANALOG PORT REQUIREMENTS

The MTA analog port represents an interface between the PacketCable/DOCSIS/IP (internet protocol) network and devices designed to function when connected to the PSTN using standard PSTN interfaces. The subscriber side of this interface is an analog interface consistent with the PSTN and the network side of this interface is a digital interface to the IP-based PacketCable network, which rides on top of the DOCSIS transport. It is expected that many operators will choose to use the PacketCable architecture to offer service to customers in residential dwellings. In such applications, the MTA will reside at the subscriber premises, either inside or outside. The MTA will, in the context of the PacketCable network, be analogous to the NIU (network interface unit) or NID (network interface device) as those terms are used in connection with the PSTN. Finally, because the network side of the port interface is digital, and the device resides close to the subscriber, the analog subscriber side of the port interface will only be required to support relatively short metallic (copper twisted pair) drops (i.e., 500 feet).

This interface is similar to the Telcordia TA-909 POTS interface requirements for FITL (fiber in the loop). Therefore, the port requirements are based on TA-909 [8]. For basic PacketCable service, the requirements can be divided into four categories:

- Loop Start Signaling (section 4.1 of [8])
- General Supervision (section 4.4 of [8])
- General Ringing (section 4.5 of [8])
- Voice Grade Analog Transmission (section 5 of [8])

The MTA analog 2-wire interface requirements are listed in the following sections.

Terminology: For the purpose of this section, the subscriber twisted pair copper wiring (typically the wiring inside the subscriber's premises) that is connected to the E-MTA analog port will be referred to as the "loop". Note that this usage is different than the way these terms may be used in the context of the PSTN, in which the "loop" is defined as the transmission path between a telephone company central office and a customer's premises. The "loop" referred to in this section, in PSTN terms, would typically be referred to as "premises wire" or "inside wire." References here to "loops" and "transmission paths" should not be confused with links from customer premises to either a telephone company office or to an MSO's head-end.

7.1 Loop Start Signaling

7.1.1 DC Supervisory Range

The DC supervisory range MUST meet: $R_{DC} \geq 450$ ohms. R_{DC} is the DC supervisory range. The actual value of R_{DC} depends on the resistance of the loop wire from the E-MTA (the subscriber's inside wiring). That is, $R_{DC} = 430 + R_{loop}$. Note that this accommodates a drop of 500 feet of AWG 22-gauge wire at 65°C.

Reference: section 4.1.1 of [8].

7.1.2 Idle State Voltage

The idle state is when the loop is open or on-hook. In this state the idle voltage satisfies:

MUST be $21\text{Vdc} \leq V_{\text{IDLE}} \leq 80\text{V dc}$

SHOULD be $42.75\text{Vdc} \leq V_{\text{IDLE}} \leq 80\text{V dc}$

ring is negative with respect to tip

ring-to-ground and tip-to-ground voltages are < 0

meet class A2 continuous source electrical safety from section 14.6 of GR-499 [5]

Note: The V_{IDLE} minimum recommendation has been added for PacketCable. In some cases, 21 Vdc causes interoperability problems with certain CPE devices.

Reference: section 4.1.2 of [8]. Modified for PacketCable.

7.1.3 Loop Closure Detection

Loop closure is off-hook. Detection of loop closure MUST meet:

Resistance $\leq R_{\text{DC}}$ between tip and ring is loop closure

Resistance $\geq 10\text{k ohms}$ between tip and ring is not loop closure

When loop closure is detected, appropriate actions as defined by the CMS will be taken.

Reference: section 4.1.4 of [8].

7.1.4 Loop Open Detection

Loop open is on-hook. Detection of loop open MUST meet:

Resistance $\geq 10\text{k ohms}$ is loop open

Resistance $\leq R_{\text{DC}} + 380\text{ ohms}$ is not loop open

The MTA MUST be able to distinguish between a hit, dial pulse, flash, or disconnect and signal appropriately to the CMS as defined in [1].

Reference: section 4.1.5 of [8]

7.1.5 Off-Hook Delay

The MTA MUST be able to detect a subscriber origination request (off-hook) and attempt to transmit the notification to the CMS within 50 msec.

2-way voice signal transmission capability on the loop established within 50 msec of detecting the origination request (off-hook)

Reference: section 4.1.7 of [8]. Modified for PacketCable.

7.1.6 On-Hook Delay

The MTA MUST be able to detect a subscriber termination request (on-hook) and attempt to transmit the notification to the CMS within 50 msec.

7.1.7 Ringsplash

When the CMS indicates one 500 msec ringsplash, the MTA MUST apply one 500 +/- 50 msec ring burst to the line.

Reference: section 4.1.9 of [8]. Note that the ringsplash requirement stated here is within the bounds of the ringsplash requirement stated in [1]. Thus, by meeting this requirement, the NCS requirement is met also.

7.1.8 Distinctive Ringing

Defined ring cadences MUST be applied to the drop within +/-50 msec resolution.

The MTA shall be able to apply any of the distinctive alerting patterns described in [1] to the line when signaled by the CMS.

Reference: section 4.1.10 of [8]. Note that the ringing requirement stated here is within the bounds of the ringing requirement stated in [1]. Thus, by meeting this requirement, the NCS requirement is met also.

7.1.9 Transmission Path

The MTA MUST support part-time on-hook transmission capabilities: part-time = within 400 msec after a ringsplash. On-hook transmission provides the capability of transmitting a voiceband signal in both directions on the loop when the loop is open (on-hook).

Reference: section 4.1.15 of [8]. Modified for PacketCable.

7.2 General Supervision

7.2.1 Off-Hook Loop Current

The MTA MUST provide at least 20 mA of loop current in the off-hook state.

Loop voltage is such that the ring conductor is negative with respect to the tip conductor.

Reference: section 4.4.1 of [8]. Modified for PacketCable.

7.2.2 Immunity to Line Crosses

Shorts between tip-to-tip, tip-to-ring, or ring-to-ring involving 2 or more lines MUST NOT damage the MTA.

Shorts between tip-to-ground or ring-to-ground involving 1 or more lines MUST NOT damage the MTA.

Reference: section 4.4.3 of [8]

7.2.3 System Generated Open Intervals

When in the loop closure state (off-hook), interruptions to loop current feed MUST NOT exceed 100 msec unless instructed by the CMS.

Reference: section 4.4.5 of [8]

7.2.4 Open Switching Interval Distortion

When in the loop closure state and providing loop current feed, loop current feed open commands of duration T MUST have resolution to +/-25 msec for $50 \leq T \leq 1000$ msec.

When in the above state, the MTA MUST continue to maintain loop closure (towards the CMS) with no interruptions >1 msec.

Loop current feed open MUST NOT exceed 5 sec in duration.

Loop current feed open is an interruption of the loop current sourced on the drop.

TR30 (TR-NWT-000303, Issue 2, October 1992) [6] specifies this MUST be satisfied for both on-hook and off-hook.

Reference: section 4.4.6 of [8]

7.2.5 Dial Pulsing

Dial pulses MAY be collected at the MTA. Depending on CMS instructions, the digits can either be individually sent or gathered according to the digit map and all digits sent in a single message.

If the MTA supports dial pulsing, the MTA MUST support 8-12 pps with 58-64% break.

Note that PacketCable does not require support for pulse dialing. Therefore, this is an optional MTA requirement.

Reference: section 4.4.9 of [8]. Modified to be optional for PacketCable.

7.2.6 DTMF Signaling

DTMF signaling will be collected at the MTA. Depending on CMS instructions, the digits can either be individually sent or gathered according to the digit map and all digits sent in a single message.

The MTA MUST NOT amplitude overload at the maximum expected DTMF signal level. (ANSI T1.401-1988 describes the maximum DTMF signal level.) Amplitude overload is any output frequency between 0 – 12 kHz greater than -28 dBm0 when the input frequency is between 600 – 1500 Hz at a power level equal to the maximum expected DTMF signal level.

Reference: section 4.4.10 of [8]

7.2.7 Dialtone Removal

The MTA MUST remove dialtone within 250 msec of detecting the first dialed digit unless otherwise instructed by the CMS.

Note: The NCS protocol defined in [1] provides the ability to request the MTA to play signals (in this case dialtone) in response to events (in this case off-hook). The protocol also provides the ability to instruct the MTA to “keep the signals active” after an event has been detected (in this case keep dialtone active even if a digit has been detected). Thus, it is not the intention of this specification to override the NCS protocol specification and as such, the CMS has the ability to override this requirement.

7.3 General Ringing

7.3.1 Alerting Signals

The MTA MUST support unbalanced or balanced ringing.

The applied cadence MUST be within +/-50 msec of the defined cadence.

Nominal cadence has a 6-sec period with 1.7-2.1 sec ringing and 3.1-5.5 sec of silence.

For Unbalanced Ringing:

- Alerting cadence is applied to ring with tip grounded.
- The dc component during ringing is such that the ring conductor is negative with respect to tip.

For Balanced Ringing:

- Alerting cadence is applied to both tip and ring, typically 180° out of phase.
- With or without a dc component.

Reference: section 4.5.2 of [8]. Modified for PacketCable for optional balanced ringing.

7.3.2 Ringing Delay

Ringing MUST be applied within 200 msec of being signaled by the CMS. The cadence MAY be entered at any point (i.e., the cadence may start with the silent period).

Reference: section 4.5.3 of [8]. Modified for PacketCable.

7.3.3 Ringing Source

MUST meet the duration-limited source safety requirements of GR-1089 [7].

Ringing frequency MUST be 20+/-1 Hz.

The dc component (offset) MUST be ≤ 75 Vdc

MUST meet 1.2 \leq peak-to-rms voltage ratio ≤ 1.6

The bridged C-weighted noise ≤ 90 dBnC when referenced to 900 ohms during ringing (i.e., the 20 Hz component < 0 dBm) and the analog voiceband lead conducted emissions criteria of TR1089 [7] MUST be met.

Reference: section 4.5.4 of [8]

7.3.4 Ringing Capability

The minimum ringing voltage MUST meet 40 Vrms across a 5 REN load on a drop with resistance $\leq R_{DC} - 400$ ohms.

Reference: section 4.5.5 of [8].

7.3.5 Ringing Capacity

The MTA MUST support 5 REN per line.

The MTA MUST support at least 10 REN per device for MTAs that support 2 or more lines.

Note: It is anticipated that many MTAs will support more than 2 lines (i.e., 4 POTS lines) but it is also unreasonable to require the MTA with more than 2 lines to support 5 REN for each line for power consumption reasons. Therefore, the minimum REN requirement of 10 REN per device, across all lines, is established.

7.3.6 Ring Trip

Ringing MUST be removed within 200 msec of detecting loop closure.

Reference: section 4.5.7 of [8].

7.3.7 Ring Trip Reporting Delay

The MTA MUST be able to detect a ring trip and attempt to transmit the notification to the CMS within 300 msec.

Reference: section 4.5.8 of [8].

7.3.8 Ring Trip Immunity

Ringing MUST NOT be tripped when a termination of 10k ohm in parallel with 6 uF is applied to tip and ring.

Ringing MUST NOT be tripped when a termination of 200 ohm is applied to tip and ring for \leq 12 msec.

Reference: section 4.5.9 of [8]

7.4 Voice Grade Analog Transmission

The PacketCable system utilizes digital transmission of voice signals to and from the MTA. The MTA converts between the digital voice signal on the IP network and the analog voice signal on the tip and ring loop. System impairments in the digital network, such as packet loss, can affect the voice signal but are outside the control of the MTA. Therefore, this section defines the analog voiceband requirements of the MTA and assumes an error-free digital network.

These requirements are derived from the PSTN which, in some cases, utilizes analog transmission from a headend central office switch to a customer. Typically, the reference point by which these requirements are measured is the middle of the switch (digital to analog). This reference point is referred to as the 0 Transmission Level Point (TLP) and could be thought of as any point in the digital portion of the network. Note that these are not end-to-end analog requirements since they apply to a single digital to analog conversion point (a typical voice call will be analog at each end with a digital network connecting the two ends).

The 0 TLP of the PacketCable system is any point in the digital IP network. The digital IP network, for voice signal transmission purposes, extends all the way to the MTA where the digital to analog conversion occurs.

These requirements only apply to the G.711 audio codec as specified in [2]. Transmission requirements for the other compression algorithms specified in [2] are not yet defined.

General: All these requirements MUST be satisfied for both on-hook and off-hook.

7.4.1 Input Impedance

600 ohms nominal

ERL (echo return loss) > 26 dB (29 dB objective).

SRL (singing return loss) > 21 dB (24 dB objective).

Reference: section 5.3.1 of [8].

7.4.2 Hybrid Balance

ERL > 21 dB (26 dB objective).

SRL > 16 dB (21 dB objective).

$ERL = 15 + L_{T1} + L_{R1}$.

$SRL = 10 + L_{T1} + L_{R1}$.

Where L_{T1} is transmit loss and L_{R1} is receive loss at 1004 Hz.

Reference: section 5.4 of [8].

7.4.3 Longitudinal Balance

200 Hz: min > 45 dB, ave > 50 dB (ave > 61 dB objective).

500 Hz: min > 45 dB, ave > 50 dB (ave > 58 dB objective).

1000 Hz: min > 45 dB, ave > 50 dB (ave > 52 dB objective).

3000 Hz: min > 40 dB, ave > 45 dB.

Reference: section 5.5 of [8].

7.4.4 MTA Loss

4 dB in the D/A direction (towards the subscriber).

2 dB in the A/D direction (from the subscriber).

This is the loss within the MTA.

Reference: section 5.8 of [8].

7.4.5 MTA Loss Tolerance

Within +/-1 dB of the MTA loss.

Reference: section 5.9 of [8].

7.4.6 Frequency Response

Off-hook transmission loss between 400-2800 Hz MUST be within -0.5 to $+1$ dB of the loss at 1004 Hz using a 0 dBm0 signal.

On-hook transmission loss between 400-2800 Hz MUST be within -1 to $+2$ dB of the loss at 1004 Hz using a 0 dBm0 signal.

(+ means more loss, - means less loss).

Reference: section 5.11 of [8].

7.4.7 60 Hz Loss

The transmission path loss at 60 Hz MUST be at least 20 dB greater than the off-hook transmission path loss at 1004 Hz. The intention is to limit the encoding of 60 Hz induction in the A/D direction.

Reference: section 5.12 of [8].

7.4.8 Amplitude Tracking

The deviation of a 1004 Hz off-hook transmission path loss relative to the loss of a 0 dBm0 input signal.

-37 to -3 -dBm0 input: ± 0.5 dB max (± 0.25 dB ave).

-50 to -37 -dBm0 input: ± 1.0 dB max (± 0.5 dB ave).

-55 to -50 -dBm0 input: ± 3.0 dB max (± 1.5 dB ave).

The deviation of a 1004 Hz on-hook transmission path loss relative to the loss of a 0 dBm0 input signal.

-37 to 0 dBm0: ± 0.5 dB max.

Reference: section 5.13 of [8].

7.4.9 Overload Compression

The increase in the off-hook transmission path loss at 1004 Hz relative to the loss of a 0 dBm0 input signal.

+3 dBm0 input: ≤ 0.5 dB increased loss.

+6 dBm0 input: ≤ 1.8 dB increased loss.

+9 dBm0 input: ≤ 4.5 dB increased loss.

This is to ensure the receiver off-hook signal can be transmitted.

Reference: section 5.18 of [8].

7.4.10 Idle Channel Noise

Not to exceed 20 dBmC at the output of the MTA (18 dBmC objective).

Reference: section 5.14 of [8].

7.4.11 Signal to Distortion

The ratio of the output signal to output C-notched noise with a 1004 Hz input signal while providing an on-hook and off-hook transmission path.

0 to -30-dBm0 input: >33-dB ratio.

-30 to -40-dBm0 input: >27-dB ratio.

-40 to -45-dBm0 input: >22-dB ratio.

Reference: section 5.15 of [8].

7.4.12 Impulse Noise

≤ 15 impulses in 15 minutes with no holding tone applied at a threshold of 47 dBmC0.

≤ 15 impulses in 15 minutes with a -13 dBm0 tone at 1004 Hz at a threshold of 65 dBmC0.

These SHOULD be met for both the on-hook and off-hook transmission path. For a line under test, other lines on the MTA SHOULD be active (off-hook, dialing, ringing, etc.).

Reference: section 5.16 of [8].

7.4.13 Intermodulation Distortion

$R_2 > 43$ dB using a -13 dBm0 input signal.

$R_3 > 44$ dB using a -13 dBm0 input signal.

R_2 and R_3 are the 2nd and 3rd order intermodulation products measured using the IEEE 743-1984 4-tone method.

Reference: section 5.17 of [8].

7.4.14 Single Frequency Distortion

Using a 0 dBm0 input signal between 0-12 kHz, the output between 0-12 kHz < -28 dBm0.

Using a 0 dBm0 input signal between 1004-1020 Hz, the output between 0-4 kHz < -40 dBm0.

Reference: section 5.19 of [8].

7.4.15 Generated Tones

< -50 dBm0 between 0-16 kHz.

Reference: section 5.20 of [8].

7.4.16 Peak-to-Average Ratio

P/AR > 90 with a -13 dBm0 input level. On-hook and off-hook transmission paths.

Reference: section 5.21 of [8].

7.4.17 Channel Crosstalk

With a 0-dBm0 signal between 200-3400 Hz applied to a line, other lines on the MTA < -65 dBm0 C message weighted output between 200-3400 Hz.

Reference: section 5.22 of [8].