

Superseded by a Subsequent Version of Document

OpenCable™ Host Device 2.0 Core Functional Requirements

OC-SP-HOST2.0-CFR-I08-060413

ISSUED

Notice

This OpenCable document is the result of a cooperative effort undertaken at the direction of Cable Television Laboratories, Inc. for the benefit of the cable industry and its customers. This document may contain references to other documents not owned or controlled by CableLabs. Use and understanding of this document may require access to such other documents. Designing, manufacturing, distributing, using, selling, or servicing products, or providing services, based on this document may require intellectual property licenses for technology referenced in the document.

Neither CableLabs nor any member company is responsible to any party for any liability of any nature whatsoever resulting from or arising out of use or reliance upon this document, or any document referenced herein. This document is furnished on an "AS IS" basis and neither CableLabs nor its members provides any representation or warranty, express or implied, regarding the accuracy, completeness, or fitness for a particular purpose of this document, or any document referenced herein.

© Copyright 2004 - 2006 Cable Television Laboratories, Inc.
All rights reserved.

Document Status Sheet

Document Control Number:	OC-SP-HOST2.0-CFR-I08-060413		
Document Title:	OpenCable™ Host Device 2.0 Core Functional Requirements		
Revision History:	D01 - OC-SP-HOST2.0-CFR-D01-040630 I01 - OC-SP-HOST2.0-CFR-I01-040831 I02 - OC-SP-HOST2.0-CFR-I02-041119 I03 - OC-SP-HOST2.0-CFR-I03-050121 I04 - OC-SP-HOST2.0-CFR-I04-050415 I05 - OC-SP-HOST2.0-CFR-I05-050503 I06 - OC-SP-HOST2.0-CFR-I06-050708 I07 - OC-SP-HOST2.0-CFR-I07-060126 I08 - OC-SP-HOST2.0-CFR-I08-060413		
Date:	April 13, 2006		
Responsible Author:	Joel Michon		
Status:	Work in Progress	Draft	Issued
Distribution Restrictions:	author only	CL/Member	CL/Member/Vendor
			Public

Key to Document Status Codes:

- Work in Progress** An incomplete document, designed to guide discussion and generate feedback which may include several alternative requirements for consideration.

- Draft** A document in specification format considered largely complete, but lacking review by Members and vendors. Drafts are susceptible to substantial change during the review process.

- Issued** A stable document, which has undergone rigorous member and vendor review and is suitable for product design and development, cross-vendor interoperability, and for certification testing.

- Closed** A static document, reviewed, tested, validated, and closed to further engineering change requests to the specification through CableLabs.

TRADEMARKS:

DOCSIS®, eDOCSIS™, M-CMTS™, PacketCable™, CableHome®, CableOffice™, OpenCable™, CableCARD™, OCAP™, DCAS™, and CableLabs® are trademarks of Cable Television Laboratories, Inc.

Table of Contents

1	INTRODUCTION (INFORMATIVE)	1
1.1	OpenCable Overview	1
1.2	OpenCable Host Device 2 Overview.....	1
1.3	Compliance Notation	2
1.4	Glossary of Terms.....	3
1.5	Abbreviations and acronyms.....	4
1.6	List of Requirements Applied to Each Hardware Profile.....	5
2	REFERENCES	13
2.1	Normative References	13
2.2	Informative References	15
2.3	Reference Acquisition	15
3	OVERVIEW OF CORE SERVICES AND FUNCTIONALITIES	17
3.1	OpenCable Host Device 2 components	17
3.1.1	Core Services (Informative).....	18
3.1.2	Core Functions and Features (Informative).....	18
3.2	General Compliance (Normative)	19
4	SECURITY	20
4.1	Conditional Access.....	20
4.2	Partitioning of Memory	20
4.3	Certificate Storage and Management.....	20
4.4	Analog Program Copy Protection.....	20
4.5	Digital Program Copy Protection.....	20
4.6	HD Copy Control	21
5	BI-DIRECTIONAL PHYSICAL LAYER CHARACTERISTICS	22
5.1	RF Interface	22
5.1.1	Maximum Individual Carrier Amplitude.....	22
5.2	Communication Channels.....	22
5.2.1	Forward Application Transport (FAT) Channel.....	23
5.2.2	NTSC Analog Channels	23
5.2.3	Out-Of-Band Signaling	23
5.3	Physical Layer Specifications.....	24
5.3.1	In-Band Downstream Channel, FDC Characteristics and RF Performance.....	24
5.3.2	Upstream Transmission Characteristics.....	29
6	CABLECARD INTERFACE	31
6.1	OpenCable Host Device 2 Functionality without a CableCARD Device.....	32

6.2 Man Machine Interface (MMI) Support	32
6.3 Software	33
6.3.1 Middleware	33
6.3.2 Software Download	33
6.3.3 Specific Application Support Resource	33
6.4 Extended Channel Support	33
7 MULTI-MEDIA INTERFACES	35
7.1 OpenCable Host Device 2 Outputs	35
7.2 OpenCable Host Input Devices	36
7.3 RF Output Requirements (Channel ¾ RF Output)	38
8 VIDEO	39
8.1 Analog Video	39
8.1.1 Analog Tuning	39
8.2 Digital Video	39
8.2.1 MPEG-2 Transport	39
8.2.2 Digital Video Decoding	39
8.2.3 Digital Television (DTV) In-Band Service/System Information	40
8.2.4 Digital Television (DTV) Out-of-Band Service/System Information	40
8.2.5 Digital Television (DTV) Closed Captioning	40
8.2.6 Digital Television (DTV) Content Advisory Information	41
8.2.7 Digital Television (DTV) Emergency Alert Service (EAS).....	42
8.3 Video Performance Specifications	42
8.4 HD Physical Interfaces	44
8.4.1 HD Analog Component Video Interface	44
8.4.2 Uncompressed Digital Video Interface	45
8.4.3 IEEE-1394 Digital Interface	45
8.5 Signal Formats	47
8.5.1 Scanning Formats for the HD Analog Component Video Interface	47
8.5.2 Colorimetry for the HD Analog Component Video Interface	47
8.5.3 Scanning Formats for the DVI Interface	47
8.5.4 Video Transmission Format for the DVI Interface	47
8.5.5 Colorimetry for the DVI Interface	48
8.5.6 Simultaneous Outputs	48
9 AUDIO	49
9.1 Audio Performance Specifications	49
9.2 Music Channel Services	49
10 OPENCABLE HOST DEVICE 2 POWERING STATES	52
10.1 CableCARD Background Mode Power Management	52
11 OPENCABLE HOST DEVICE 2 DIAGNOSTICS	53
11.1 Diagnostic Parameters	53
11.1.1 Memory Allocation	53

11.1.2 Software Version Number 54

11.1.3 Firmware Version 54

11.1.4 MAC Addresses 54

11.1.5 Network Addresses 54

11.1.6 Status of FDC 54

11.1.7 Status of FAT 54

11.1.8 Status of RDC 55

11.1.9 Current Channel Status 55

11.1.10 IEEE-1394 Port Status 55

11.1.11 DVI / HDMI Port Status 56

11.1.12 Status of DOCSIS transport channels 56

11.1.13 Home Network Status 57

12 MECHANICAL 58

13 DSG MODE OPERATION 61

13.1 DSG mode selection 62

13.2 DSG Advanced Mode Initialization 63

13.3 DSG Advanced Mode Operation 63

13.4 DSG Basic Mode Operation 64

13.5 Application tunnels 64

13.6 Internet Protocol Flows 64

13.6.1 eSTB DHCP Requirements 66

13.6.2 CARD DHCP Requirements 69

13.6.3 IP Address Lease Renewal 71

13.6.4 IP packet Forwarding 72

14 MANAGEMENT REQUIREMENTS 74

14.1 SNMP Protocol requirements 74

14.2 Requirements for OC-STB-HOST-MIB 74

14.3 Other Requirements 74

ANNEX A MIB OBJECTS REQUIREMENTS 76

ANNEX B OC-STB-HOST-MIB (NORMATIVE) 81

APPENDIX I REVISION HISTORY (INFORMATIVE) 111

List of Figures

Figure 1.2–1 - OpenCable Host Device 2 Types	1
Figure 3.1–1 - Block Diagram of the OpenCable Set-top 2 (Informative)	17
Figure 6–1 - Block Diagram of the OpenCable CableCARD Interface (Informative)	31
Figure 13–1 - Host 2.0 DSG architecture.....	61

List of Tables

Table 5.3-1- Analog and FAT Channel: RF Performance Parameters (0° - 40° C)	24
Table 5.3-2 - FDC Channel: RF Performance Parameters (0° - 40° C)	26
Table 5.3-3 - Adjacent Channel Characteristics	28
Table 5.3-4 - Reverse Data Channel RF & Modulation Performance Parameters (0° - 40° C)	29
Table 7.2-1 – Function Key Shapes and Colors	36
Table 7.2-2 – Key Event Labels.....	36
Table 7.3-1 - Channel ¾ RF Output Performance Parameters (0° - 40° C)	38
Table 8.3-1 - Composite Analog Video Output Performance Parameters (0° - 40° C) ...	43
Table 8.3-2 - Analog Video Output Performance when processing a digital video program source (0°- 40° C)	44
Table 8.4-1 - Connector Color Code Assignment	44
Table 9.2-1 - RF Output Audio Performance	50
Table 9.2-2 - Baseband Audio Output when a Digital Service is Selected	50
Table 9.2-3 - Baseband Audio Output with Analog Service*	51
Table 12–1 - Environmental / Mechanical Requirements	58
Table 13.6-1 - Embedded OpenCable Host 2.0 Device DHCP Request	73
Table 14.3-1 - [RFC3418] sysDescr Format	75

1 INTRODUCTION (Informative)

1.1 OpenCable Overview

The goal of the OpenCable specifications is to help the cable industry deploy interactive services in North America. Information is presented in this document that defines the range of minimum capabilities to be supported by Bidirectional digital set-top boxes (OCS2) and integrated terminal devices (OCT2). OpenCable Project information including Unidirectional specifications and other OpenCable Project information is available on the OpenCable website <http://www.opencable.com/>.

The OpenCable specifications:

1. Provide integrated environments for broadcast services (analog and digital) and real-time interactive multimedia services.
2. Require standards and interoperability. OpenCable takes advantage of standard computing and network architectures, wherever possible, to minimize costs and maximize inclusion of emerging technologies. Standards may include international standards, North American standards, or published *de facto* industry standards. In all cases, the acquisition of the necessary software, hardware, and intellectual properties will be achievable at fair and reasonable costs. All standard interfaces will be in the public domain or will be available for license at a fair and reasonable cost. Closed proprietary systems are to be avoided.
3. Require portability. FCC regulations adopted under the "retail availability" provisions of the Communications Act provide for retail cable navigation devices to operate with CableCARD™ modules. The OpenCable system permits "point-of-deployment decisions" for network, security and operator-programmed user interfaces to enable the anticipated variety of retail devices and promotes the portability of such devices.
4. Define a renewable and replaceable core encryption system called the CableCARD device.
5. Provide cable Multiple System Operators (MSOs) the ability to inform the navigation device (Host) of the offered services and the Host device with the tools to display the cable services as intended by the MSO.
6. Co-exist with the embedded base of existing set-top devices.

1.2 OpenCable Host Device 2 Overview

This document describes the requirements for the OpenCable Host Device 2. These devices include OpenCable Set-top 2 (OCS2) and OpenCable Terminal 2 (OCT2) devices.

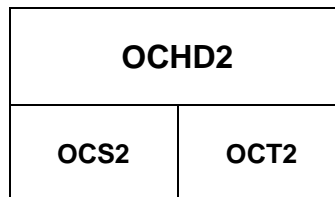

Figure 1.2–1 - OpenCable Host Device 2 Types

The goals and objectives of the OpenCable Host Device 2.0 are:

- To support non-scrambled analog services as well as new scrambled or in-the-clear digital services.
- To receive digital premium (scrambled) cable services via an interface with a CableLabs Qualified CableCARD Device.

- To support interactive and two-way services through standardized OOB and DOCSIS® data channels and direct connection to the cable plant.

Information on the OpenCable Project can be obtained from the OpenCable website at <http://www.opencable.com/>, and information on the DOCSIS specifications (including DSG) can be found at the DOCSIS web site at <http://www.cablemodem.com/>.

Below is more detail on the basic functionality of the OpenCable Host Device 2 types.

OpenCable Set-top 2 (OCS2)

- Two-way connectivity support via both ANSI/SCTE 55-1,-2 OOB and DOCSIS with DSG functionality;
- OpenCable Application Platform (OCAP) 1.0 support;
- MPEG2 Main Profile @ Main Level (MP@ML) Standard Definition and Main Profile @ High Level (MP@HL) High-Definition decoding;
- Digital Visual Interface (DVI) or High-Definition Multimedia Interface (HDMI) output (source) with HDCP encryption;
- IEEE-1394 output (source) with DTCP encryption;
- Optional MPEG encoding of received analog channels for transport on the IEEE-1394 output;
- Multi-Stream or Single-Stream CableCARD interface support.

OpenCable Terminal 2 (OCT2)

- Two-way connectivity support via both ANSI/SCTE 55-1,-2 OOB and DOCSIS with DSG functionality;
- OpenCable Application Platform (OCAP) 1.0 support;
- MPEG2 Main Profile @ Main Level (MP@ML) Standard Definition and Main Profile @ High Level (MP@HL) High-Definition decoding and display;
- Digital Visual Interface (DVI) or High-Definition Multimedia Interface (HDMI) input (sink) with HDCP encryption; DVI or HDMI output (source) optional;
- IEEE-1394 input (sink) with DTCP encryption including the capability to switch between analog and digital inputs as in [CEA-775-B];
- Multi-Stream or Single-Stream CableCARD interface support.

1.3 Compliance Notation

Throughout this document, the words used to provide normative statements are capitalized as shown below:

MUST / SHALL	These words or the adjective "REQUIRED" means that the item is an absolute requirement of this specification.
MUST NOT / SHALL NOT	These phrases mean that the item is an absolute prohibition of this specification.
SHOULD	This word or the adjective "RECOMMENDED" means that there may exist valid reasons in particular circumstances to ignore this item, but the full implications should be understood and the case carefully weighed before choosing a different course.

SHOULD NOT This phrase means that there may exist valid reasons in particular circumstances when the listed behavior is acceptable or even useful, but the full implications should be understood and the case carefully weighed before implementing any behavior described with this label.

MAY This word or the adjective "OPTIONAL" means that this item is truly optional. One vendor may choose to include the item because a particular marketplace requires it or because it enhances the product, for example; another vendor may omit the same item.

1.4 Glossary of Terms

This document uses the following terms:

OpenCable Host Device 2	<ul style="list-style-type: none"> • A cable receiver that is compliant with one of the hardware profiles defined by this specification. The OCHD2 profiles include: • OpenCable Set-top 2 (OCS2) • OpenCable Terminal 2 (OCT2)
OpenCable Set-top 2	A cable receiver that has no integrated display and is compliant with the OCS2 profile defined by this specification.
OpenCable Terminal 2	A cable receiver that includes an integrated display and is compliant with the OCT2 profile defined by this specification.
Embedded Cable Modem (eCM)	A Cable Modem that is integrated into an OCHD2 for Out-Of-Band signaling, implemented according to the DOCSIS 2.0 spec [RFIV2.0], [eDOCSIS] and supports [DSG].
Network Controller	This is the computer system responsible for managing the CableCARD devices within a cable system. It manages CableCARD devices through control and information messages sent via a dedicated Out-Of-Band channel or DSG channel.
Out-Of-Band Messaging	The control and information messages sent from the Network Controller via the Host to the CableCARD requiring a dedicated QPSK channel or DSG channel that may contain the following types of messages: <ul style="list-style-type: none"> • Conditional Access (CA) messages including entitlements • System Information (SI) messages • Electronic Program Guide (EPG) messages • Emergency Alert System (EAS) messages • Other generic messages
Controlled Content	Content that has been transmitted from the CableCARD Device with the encryption mode indicator (EMI) bits set to a value other than zero [0].
CableCARD™	A CableCARD device is a detachable device distributed by cable providers that connects to the Host Device. The interface between the CableCARD device and the Host Device is specified by the OpenCable CableCARD Interface 2.0 Specification or OpenCable CableCARD Interface Specification [CCIF2.0]. CableCARD functionality includes copy protection and private CA functions beyond the scope of this specification.

1.5 Abbreviations and acronyms

CA	Conditional Access
CM	Cable Modem
CMTS	Cable Modem Termination System
CVCT	Cable Virtual Channel Table
DOCSIS®	Data-Over-Cable Service Interface Specifications
DSG	DOCSIS Set-top Gateway
DSGCC	DOCSIS Set-top Gateway Client Controller
DTCP	Digital Transmission Content Protection
DTLA	Digital Transmission Licensing Administrator
DVI	Digital Video Interface
DVS	Digital Video Subcommittee
EAS	Emergency Alert System
eCM	Embedded Cable Modem
EPG	Electronic Program Guide
FAT Channel	Forward Application Transport Channel
FDC	Forward Data Channel
HD	High Definition
HDCP	High-Bandwidth Digital Content Protection
HDMI	High-Definition Multimedia Interface
HDTV	High Definition Television
HFC	Hybrid Fiber/Coax
IP	Internet Protocol
MAC	Media Access Control
MIB	Management Information Base
MMI	Man Machine Interface

MPEG	Moving Picture Experts Group
MSO	Multiple System Operator
MTA	Media Terminal Adaptor
OCAP	OpenCable Application Platform
OCHD2	OpenCable Host Device 2 (includes OCS2 and OCT2 profiles)
OCS2	OpenCable Set-top 2
OCT2	OpenCable Terminal 2
OOB	Out-Of-Band
OSD	On-screen Display
POD Module	Point Of Deployment Module (also known as CableCARD Device)
RDC	Reverse Data Channel
SCTE	Society of Cable Telecommunications Engineers
SD	Standard Definition
SI	System Information
SNMP	Simple Network Management Protocol
SPTS	Single Program Transport Stream
TCP	Transmission Control Protocol
TVCT	Terrestrial Virtual Channel Table
UDP	User Datagram Protocol

1.6 List of Requirements Applied to Each Hardware Profile

Requirement	OCS2			OCT2		
	Required	Required if present	Optional	Required	Required if present	Optional
OCHD2-1	•			•		
OCHD2-2	•			•		
OCHD2-3	•			•		
OCHD2-4	•					
OCHD2-5	•			•		
OCHD2-6	•			•		
OCHD2-7	•			•		

Requirement	OCS2			OCT2		
	Required	Required if present	Optional	Required	Required if present	Optional
OCHD2-8	•					
OCHD2-9					•	
OCHD2-10	•			•		
OCHD2-11	•			•		
OCHD2-12	•			•		
OCHD2-13	•			•		
OCHD2-14	•			•		
OCHD2-15a	•			•		
OCHD2-15b	•			•		
OCHD2-16		•			•	
OCHD2-17		•			•	
OCHD2-18	•			•		
OCHD2-19	•			•		
OCHD2-20	•			•		
OCHD2-21	•			•		
OCHD2-22	•			•		
OCHD2-23	•			•		
OCHD2-24	•			•		
OCHD2-25	•			•		
OCHD2-26	•			•		
OCHD2-27	•			•		
OCHD2-28	•					
OCHD2-28a					•	
OCHD2-29	•			•		
OCHD2-30	•			•		
OCHD2-31	•			•		
OCHD2-32	•			•		
OCHD2-33	•			•		
OCHD2-34	•			•		
OCHD2-35	•			•		
OCHD2-36	•			•		
OCHD2-37	•			•		
OCHD2-38	•			•		
OCHD2-39	•			•		
OCHD2-40	•			•		
OCHD2-41	•			•		
OCHD2-42	•			•		
OCHD2-43	•			•		
OCHD2-44	•			•		
OCHD2-45	•			•		
OCHD2-46	•			•		
OCHD2-47a	•			•		
OCHD2-47b			•			•
OCHD2-48	•			•		
OCHD2-49	•			•		
OCHD2-50	•			•		
OCHD2-51	•					

Requirement	OCS2			OCT2		
	Required	Required if present	Optional	Required	Required if present	Optional
OCHD2-52				•		
OCHD2-53	•					
OCHD2-54				•		
OCHD2-55a	•			•		
OCHD2-55b	•			•		
OCHD2-56	•			•		
OCHD2-57	•			•		
OCHD2-58	•			•		
OCHD2-59	•			•		
OCHD2-60	•			•		
OCHD2-61	•			•		
OCHD2-62	•			•		
OCHD2-63	•			•		
OCHD2-64	•			•		
OCHD2-65	•			•		
OCHD2-66	•			•		
OCHD2-67	•			•		
OCHD2-68	•			•		
OCHD2-69	•			•		
OCHD2-70	•			•		
OCHD2-71	•			•		
OCHD2-72	•			•		
OCHD2-73	•			•		
OCHD2-74a	•					
OCHD2-74b	•					
OCHD2-75a					•	
OCHD2-75b					•	
OCHD2-76	•					
OCHD2-77					•	
OCHD2-78	•				•	
OCHD2-79	•					
OCHD2-80					•	
OCHD2-81	•					
OCHD2-82					•	
OCHD2-83	•					
OCHD2-84					•	
OCHD2-85	•					
OCHD2-86					•	
OCHD2-87	•				•	
OCHD2-88	•					
OCHD2-89					•	
OCHD2-90a	•				•	
OCHD2-90b	•				•	
OCHD2-91a	•				•	
OCHD2-91b	•				•	
OCHD2-92	•					
OCHD2-93					•	

Requirement	OCS2			OCT2		
	Required	Required if present	Optional	Required	Required if present	Optional
OCHD2-94	•				•	
OCHD2-95	•					
OCHD2-96				•		
OCHD2-97	•			•		
OCHD2-97b	•			•		
OCHD2-98	•			•		
OCHD2-99	•			•		
OCHD2-100	•			•		
OCHD2-101	•			•		
OCHD2-102	•			•		
OCHD2-103	•			•		
OCHD2-104	•			•		
OCHD2-105	•			•		
OCHD2-106	•			•		
OCHD2-107	•					
OCHD2-108				•		
OCHD2-109	•					
OCHD2-110				•		
OCHD2-111	•			•		
OCHD2-112	•			•		
OCHD2-113	•			•		
OCHD2-114	•			•		
OCHD2-115	•			•		
OCHD2-116	•					
OCHD2-117					•	
OCHD2-118		•				
OCHD2-119					•	
OCHD2-120	•			•		
OCHD2-121	•				•	
OCHD2-122			•			•
OCHD2-123	•			•		
OCHD2-124	•					
OCHD2-125					•	
OCHD2-126			•			•
OCHD2-127	•					
OCHD2-128					•	
OCHD2-129	•					
OCHD2-130					•	
OCHD2-131		•			•	
OCHD2-132	•			•		
OCHD2-133	•			•		
OCHD2-134	•			•		
OCHD2-135	•				•	
OCHD2-136		•			•	
OCHD2-137		•			•	
OCHD2-138	•					
OCHD2-139				•		

Requirement	OCS2			OCT2		
	Required	Required if present	Optional	Required	Required if present	Optional
OCHD2-140						•
OCHD2-141		•				
OCHD2-142					•	
OCHD2-143		•				
OCHD2-144					•	
OCHD2-145					•	
OCHD2-146	•			•		
OCHD2-147	•			•		
OCHD2-148	•			•		
OCHD2-149a	•					
OCHD2-149b				•		
OCHD2-150a	•				•	
OCHD2-150b		•			•	
OCHD2-150c		•			•	
OCHD2-150d		•			•	
OCHD2-151	•			•		
OCHD2-152	•					
OCHD2-153	•					
OCHD2-154	•					
OCHD2-155		•			•	
OCHD2-156		•			•	
OCHD2-157		•			•	
OCHD2-158		•			•	
OCHD2-159	•					
OCHD2-160				•		
OCHD2-161	•					
OCHD2-162	•					
OCHD2-163	•			•		
OCHD2-163a	•			•		
OCHD2-163b	•			•		
OCHD2-164	•			•		
OCHD2-165			•			
OCHD2-166	•				•	
OCHD2-167	•				•	
OCHD2-168	•			•		
OCHD2-169	•					
OCHD2-170					•	
OCHD2-171	•					
OCHD2-172					•	
OCHD2-173	•				•	
OCHD2-174	•				•	
OCHD2-175	•				•	
OCHD2-176	•			•		
OCHD2-177	•					
OCHD2-178	•			•		
OCHD2-179	•			•		
OCHD2-180	•			•		

Requirement	OCS2			OCT2		
	Required	Required if present	Optional	Required	Required if present	Optional
OCHD2-181	•			•		
OCHD2-182	•			•		
OCHD2-183	•			•		
OCHD2-184	•			•		
OCHD2-185	•			•		
OCHD2-186	•			•		
OCHD2-187	•			•		
OCHD2-188	•			•		
OCHD2-189	•			•		
OCHD2-190	•			•		
OCHD2-191	•			•		
OCHD2-192	•			•		
OCHD2-192a		•			•	
OCHD2-193	•			•		
OCHD2-194	•			•		
OCHD2-195	•			•		
OCHD2-196	•			•		
OCHD2-197	•			•		
OCHD2-198	•			•		
OCHD2-199a	•			•		
OCHD2-199b	•			•		
OCHD2-200	•			•		
OCHD2-201	•			•		
OCHD2-202	•			•		
OCHD2-203	•			•		
OCHD2-204	•			•		
OCHD2-205	•			•		
OCHD2-206	•			•		
OCHD2-207	•			•		
OCHD2-208	•			•		
OCHD2-209	•			•		
OCHD2-210	•			•		
OCHD2-210a	•			•		
OCHD2-210b	•			•		
OCHD2-210c	•			•		
OCHD2-210d	•			•		
OCHD2-210e	•			•		
OCHD2-210f	•			•		
OCHD2-210g	•			•		
OCHD2-211a	•			•		
OCHD2-211b	•			•		
OCHD2-211c	•			•		
OCHD2-211d			•			•
OCHD2-211e		•			•	
OCHD2-211f	•			•		
OCHD2-211g	•			•		
OCHD2-211h	•			•		

Requirement	OCS2			OCT2		
	Required	Required if present	Optional	Required	Required if present	Optional
OCHD2-211i	•			•		
OCHD2-211j	•			•		
OCHD2-211k	•			•		
OCHD2-211l	•			•		
OCHD2-211m	•			•		
OCHD2-211n			•			•
OCHD2-211o	•			•		
OCHD2-211p	•			•		
OCHD2-211q	•			•		
OCHD2-211r	•			•		
OCHD2-211s	•			•		
OCHD2-211t	•			•		
OCHD2-211u	•			•		
OCHD2-211v	•			•		
OCHD2-211w	•			•		
OCHD2-211x	•			•		
OCHD2-211y	•			•		
OCHD2-212a	•			•		
OCHD2-212b	•			•		
OCHD2-212c	•			•		
OCHD2-212d	•			•		
OCHD2-212e	•			•		
OCHD2-212f	•			•		
OCHD2-212g	•			•		
OCHD2-212h	•			•		
OCHD2-212i	•			•		
OCHD2-212j	•			•		
OCHD2-212k	•			•		
OCHD2-212l	•			•		
OCHD2-212m	•			•		
OCHD2-212n	•			•		
OCHD2-212o	•			•		
OCHD2-212p	•			•		
OCHD2-212q	•			•		
OCHD2-212r	•			•		
OCHD2-212s	•			•		
OCHD2-212t	•			•		
OCHD2-212u	•			•		
OCHD2-212v	•			•		
OCHD2-213a	•			•		
OCHD2-213b	•			•		
OCHD2-213c			•			•
OCHD2-213d	•			•		
OCHD2-213e	•			•		
OCHD2-213f	•			•		
OCHD2-213g	•			•		
OCHD2-213h	•			•		

Requirement	OCS2			OCT2		
	Required	Required if present	Optional	Required	Required if present	Optional
OCHD2-213i	•			•		
OCHD2-213j	•			•		
OCHD2-213k	•			•		
OCHD2-213l	•			•		
OCHD2-213m	•			•		
OCHD2-213n	•			•		
OCHD2-213o	•			•		
OCHD2-216			•			•
OCHD2-217	•			•		
OCHD2-218	•			•		
OCHD2-219	•			•		
OCHD2-220	•			•		
OCHD2-221	•			•		

2 REFERENCES

2.1 Normative References

In order to claim compliance with this specification, it is necessary to conform to the following standards and other works as indicated, in addition to the other requirements of this specification. Notwithstanding, intellectual property rights may be required to use or implement such normative references.

All references are subject to revision, and parties to agreement based on this specification are encouraged to investigate the possibility of applying the most recent editions of the documents listed below.

- [A/52A] ATSC A/52A: Digital Audio Compression Standard
- [A/53C] ATSC A/53C with Amendment 1: ATSC Digital Television Standard
- [A/65B] ATSC A/65B: Program and System Information Protocol for Terrestrial Broadcast and Cable (Revision B)
- [CEA-542-B] EIA/CEA-542-B: Cable Television Channel Identification Plan
- [CEA-608-B] CEA-608-B: Recommended Practice for Line 21 Data Service
- [EIA 708B] EIA 708B: Digital Television (DTV) Closed Captioning
- [47CFR15] 47CFR15: Radio Frequency Devices, Class B, FCC
- [47CFR76] 47CFR76: Cable Television Service, FCC
- [IEEE-1394] IEEE-1394, 1995: Standard for a High Performance Serial Bus
- [CCIF2.0] OC-SP-CCIF2.0-I05-060413: OpenCable CableCARD Interface 2.0 Specification, April 13, 2006, Cable Television Laboratories, Inc.
- [CCCP2.0] OC-SP-CCCP2.0-I02-050708: OpenCable CableCARD Copy Protection 2.0 Specification, July 8, 2005, Cable Television Laboratories, Inc.
- [ISO 13818-1] ISO/IEC 13818-1, 200: Information technology—Generic coding of moving pictures and associated audio (MPEG): Systems
- [ISO 13818-2] ISO/IEC 13818-2, 2000: Information technology—Generic coding of moving pictures and associated audio (MPEG): Video
- [SCTE 01] ANSI/SCTE 01, 1996: (formerly IPS-SP-400): Recommended "F" Port (Female) Specification
- [SCTE 07] ANSI/SCTE 07, 2000: Digital Video Transmission Standard for Cable Television
- [EIA-679-B] EIA-679-B (Part B): National Renewable Security Standard, March 2000
- [SCTE 20] ANSI/SCTE 20, 2001: Standard Methods for Carriage of Closed Captions and Non-Real Time Sampled Video. Note: Non-Real Time Sampled Video support is "optional" for Host Devices.
- [SCTE 55-2] ANSI/SCTE 55-2, 2002: March 10, 2002, Digital Broadband Delivery System: Out-of-Band Transport Part 2: Mode B
- [SCTE 55-1] ANSI/SCTE 55-1, 2002: February 25, 2002, Digital Broadband Delivery System: Out-of-Band Transport Part 1: Mode A
- [SCTE 26] ANSI/SCTE 26, 2004: Home Digital Network Interface Specification with Copy Protection
- [SCTE 18] SCTE 18, 2002 (ANSI-J-STD-042-2002): Emergency Alert Message for Cable

- [SCTE 65] ANSI/SCTE 65, 2002: Service Information Delivered Out-of-Band for Digital Cable Television
- [SCTE 54] ANSI/SCTE 54, 2004: Digital Video Service Multiplex and Transport System Standard for Cable Television
- [SCTE 40] ANSI/SCTE 40, 2004: Digital Cable Network Interface Standard
- [CEA-775-B] CEA-775-B, 2004: DTV 1394 Interface Specification
- [DTCP] 5C Digital Transmission Content Protection Specification and License
- [OCAP] OC-SP-OCAP1.0-I16-050803: OpenCable Application Platform Specification (OCAP) 1.0, August 3, 2005, Cable Television Laboratories, Inc.
- [OC-CD] OC-SP-CD-IF-I08-040831: OpenCable Common Download Specification, August 31, 2004, Cable Television Laboratories, Inc.
- [OC-SEC] OC-SP-SEC-I06-060413: OpenCable System Security Specification, April 13, 2006, Cable Television Laboratories, Inc.
- [ISO 13818-6] ISO/IEC 13818-6, 1998: Information technology—Generic coding of moving pictures and associated audio information—Part 6: Extensions for Digital Storage Media—Command and Control (DSM-CC)
- [RFIV2.0] CM-SP-RFIV2.0-I10-051209: Data-Over-Cable Service Interface Specifications, Radio Frequency Interface Specification, December 9, 2005, Cable Television Laboratories, Inc.
- [OSSIV2.0] SP-OSSIV2.0-I09-050812: Data-Over-Cable Service Interface Specifications, Operations Support System Interface Specification, August 12, 2005, Cable Television Laboratories, Inc.
- [BPI+] CM-SP-BPI+-I12-050812: Data-Over-Cable Service Interface Specifications, Baseline Privacy Plus Interface Specification, August 12, 2005, Cable Television Laboratories, Inc.
- [DSG] CM-SP-DSG-I07-060407: DOCSIS Set-top Gateway (DSG) Interface Specification, April 7, 2006, Cable Television Laboratories, Inc.
- [CEA-770.3-C] CEA-770.3-C: High Definition TV Analog Component Video Interface
- [CEA-861-B] CEA-861-B: A DTV Profile for Uncompressed High Speed Digital Interfaces
- [SCTE 43] ANSI/SCTE 43, 2003: Digital Video Systems Characteristics Standard for Cable Television
- [DVI] Digital Visual Interface, Digital Display Working Group, Revision 1.0, April 2, 1999
- [ITU-R-BT.709-2] ITU-R-BT.709-2: Parameter Values for the HDTV Standard for Production and International Program Exchange
- [IEC 61937] IEC 61937 (2000-04): Digital audio - Interface for non-linear PCM encoded audio bitstreams applying IEC 60958
- [SCTE 28] ANSI/SCTE 28, 2004: HOST-POD Interface Standard
- [HDCP] High-bandwidth Digital Content Protection System, Digital Content Protection LLC, Revision 1.1, 9 June, 2003
- [HDMI] High-Definition Multimedia Interface, Specification Version 1.0, December 9, 2002
- [SCTE 21] ANSI/SCTE 21, 2001 (formerly DVS 053): Standard for Carriage of NTSC VBI Data in Cable Digital Transport Streams
- [CEA-23] CEA-23: RF Interface Specification for Television Receiving and Cable Television Systems
- [eDOCSIS] CM-SP-eDOCSIS-I08-060407: Data-Over-Cable Service Interface Specifications, eDOCSIS Specification, April 7, 2006, Cable Television Laboratories, Inc.

- [AV/C] AV/C: Digital Interface Command Set General Specification, Version 4.0
- [CEA-931-B] CEA-931-B: Remote Control Command Pass-through Standard for Home Networking
- [Macrovision] Specifications of the Macrovision Copy Protection Process for STB/IRD Products Revision 7.1.S1, (October 1,1999)
- [CEA-766-A] CEA-766-A: U.S. Regional Rating Table (RRT) and Content Advisory Descriptor for Transport of Content Advisory Information Using ATSC A/65 Program and System Information Protocol (PSIP)
- [CHILA] CableLabs CableCARD-Host Interface License Agreement
- [RFC1902] Structure of Management Information for Version 2 of the Simple Network Management Protocol (SNMPv2)
- [RFC 2131] Dynamic Host Configuration Protocol
- [RFC 2132] DHCP Options and BOOTP Vendor Extensions
- [RFC 3396] Encoding Long Options in the Dynamic Host Configuration Protocol (DHCPv4)
- [RFC3411] An Architecture for Describing Simple Network Management Protocol (SNMP) Management Frameworks
- [RFC3412] Message Processing and Dispatching for the Simple Network Management Protocol (SNMP)
- [RFC3413] Simple Network Management Protocol (SNMP) Applications
- [RFC3414] User-based Security Model (USM) for version 3 of the Simple Network Management Protocol (SNMPv3)
- [RFC3415] View-based Access Control Model (VACM) for the Simple Network Management Protocol (SNMP)
- [RFC3418] Management Information Base (MIB) for the Simple Network Management Protocol (SNMP)
- [RFC3584] Coexistence between Version 1, Version 2, and Version 3 of the Internet-standard Network Management Framework

2.2 Informative References

- [TIA-250-C] EIA/TIA-250-C: Electrical Performance Standards for Television Relay Facilities
- [MIL-C-39012] MIL-C-39012: General Specifications for Connectors, Coaxial, Radio Frequency

2.3 Reference Acquisition

CableLabs Specifications:

Cable Television Laboratories, Inc., 858 Coal Creek Circle, Louisville, CO 80027;
Phone: 303-661-9100; Fax 303-661-9199; <http://www.cablelabs.com/>

SCTE/DVS Standards:

SCTE - Society of Cable Telecommunications Engineers Inc., 140 Philips Road, Exton, PA 19341
Phone: 610-363-6888 / 800-542-5040; Fax: 610-363-5898; <http://www.scte.org/>

ISO/IEC Standards:

ISO Central Secretariat: International Organization for Standardization (ISO), 1, rue de Varembé, Case postale 56, CH-1211 Geneva 20, Switzerland; Internet: <http://www.iso.ch/>

HDCP Specifications and License

Digital Content Protection, LLC, C/O Intel Corporation, Stephen Balogh, JF2-55, 2111 NE 25th Ave Hillsboro, OR 97124; <http://www.digital-cp.com/>

HDMI Specifications

HDMI Licensing, LLC, 1060 E. Arques Avenue, Suite 100, Sunnyvale, CA 94085, USA; <http://www.hdmi.org/>

DTCP Specifications and License

Digital Transmission Licensing Administrator, LLC, 225 B Cochrane Circle, Morgan Hill, California 95037 USA; <http://www.dtcp.com/>

DDWG Specifications:

Digital Display Working Group (DDWG), M/S JF3-361; 2111 NE 25th Avenue, Hillsboro, OR 97124-5961, USA. Fax +1-503-264-5959; Email: ddwg.if@intel.com; Internet: www.ddwg.org

3 OVERVIEW OF CORE SERVICES AND FUNCTIONALITIES

3.1 OpenCable Host Device 2 components

This section describes the core services that OCHD2s MUST support as well as the core functions required to implement those services. A block diagram of the OpenCable Set-top Device components is shown below.

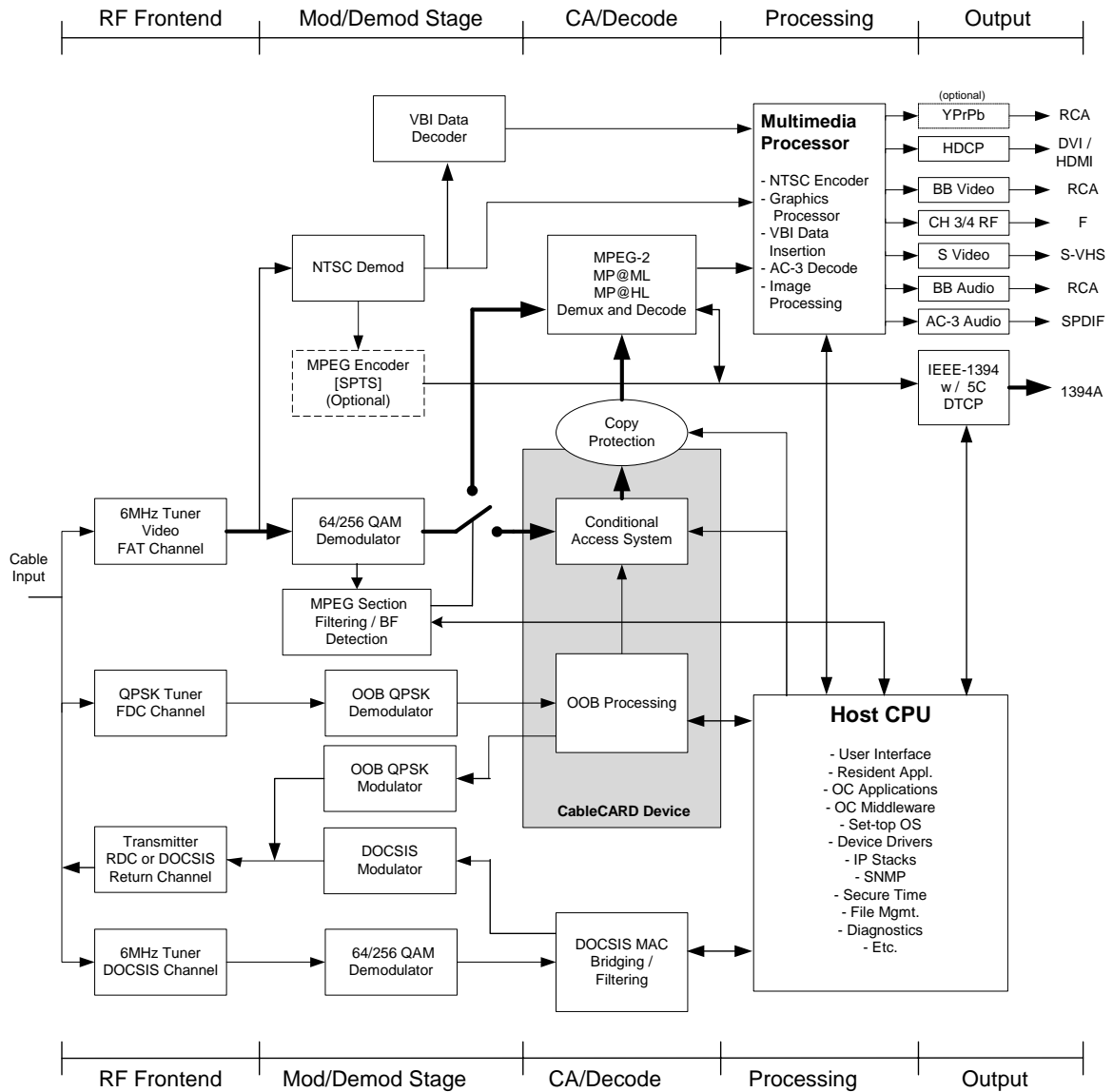

Figure 3.1-1 - Block Diagram of the OpenCable Set-top 2 (Informative)

The OCHD2 receives multimedia information by tuning to one of many 6 MHz input channels available via a bi-directional or uni-directional cable connection. When the input channel is an analog channel, the signal is processed via the NTSC decoder and the VBI data decoder. When the input channel is a digital channel, it is processed via the QAM demodulator and then passed to the CableCARD Device where secure and scrambled information is processed. Unscrambled information is passed through the CableCARD Device to the MPEG-2 Transport Demultiplexer. When the CableCARD Device is not inserted, the output of the QAM demodulator is

routed directly to the MPEG-2 Transport Demultiplexer. The multi-media processor handles the synchronization and display of audio-visual material.

Based on the network configuration, the OCHD2 receives control information and other data by either tuning to an Out-Of-Band (OOB) Forward Data Channel (FDC) channel or via the DSG channel. The Out-Of-Band mode is communicated by the CableCARD Device to the Host via the CableCARD Interface [CCIF2.0]. The transport of the OOB (FDC / RDC) messaging is detailed in [SCTE 55-2] and [SCTE 55-1]. The transport of the DSG messaging is detailed in [DSG]. The Host cannot assume which mode is supported on the network; therefore both modes must be available within the Host.

3.1.1 Core Services (Informative)

The following services are provided by the Core Requirements for OCHD2s:

- Analog NTSC audio-visual programming: (unscrambled).
- Digital audio-visual programming utilizing MPEG-2 main profile @ main level and main profile @ high level video and Dolby AC-3 audio including broadcast (unscrambled), subscription-based (scrambled), music channels, Impulse Pay-Per-View (scrambled), VOD and Subscription VOD (scrambled), Switched digital broadcast and other interactive services.
- Support of digital high definition audio-visual programming by full decoding.
- [OCAP] based interactive applications.

3.1.2 Core Functions and Features (Informative)

The following features and functions are necessary to support the core services:

- Input range of 54-864 MHz or greater, analog and digital (64/256 QAM) tuning and demodulation
- Closed Caption pass-through (line 21, fields 1 and 2) output for analog video input (OCS2)
- Closed Caption reinsertion into the VBI of reconstructed analog video output when input is digital video
- Copy protection on analog and digital outputs including the ability to disable outputs under OCAP control
- Emergency Alert System signaling (compliant with [SCTE 18])
- QPSK Out-Of-Band receiver compliant with [SCTE 55-2] and [SCTE 55-1]
- QPSK Out-Of-Band transmitter compliant with [SCTE 55-2] and [SCTE 55-1]
- Analog NTSC RF Channel $\frac{3}{4}$ output (OCS2)
- Baseband Video output (OCS2)
- L&R Baseband Audio outputs (OCS2)
- SP/DIF Digital Audio output (OCS2)
- High speed IEEE-1394 digital interface (see [SCTE 26]) with [DTCP]
- CableCARD digital interface (see OpenCable CableCARD™ Interface 2.0 Specification or OpenCable CableCARD Interface Specification [CCIF2.0])
- OpenCable CableCARD Copy Protection 2.0 Specification [CCCP2.0]
- Out-Of-Band messaging via [DSG]
- An embedded cable modem with DSG functionality compliant with [RFIV2.0]
- Optional High-definition analog output ([CEA-770.3-C] Analog Component Video specification)
- Digital Visual Interface (DVI) or High-Definition Multimedia Interface (HDMI) for uncompressed digital video with [HDCP]
- Implementation of [OCAP] middleware including processing of interactive services

3.2 General Compliance (Normative)

Any features of an OCHD2 mandated by law or FCC regulation (e.g., Emergency Alert System, V-Chip) SHALL be supported in the Core Requirements for all OCHD2s.

- OCHD2-1: The OCHD2 manufacturer SHALL confirm compliance with all applicable FCC rules and regulations.
- OCHD2-2: The OCHD2 manufacturer SHALL confirm compliance with all applicable UL rules and regulations.
- OCHD2-3: The OCHD2 SHALL comply with the specifications described in: Table 5.3-1, Table 5.3-2, Table 5.3-3, Table 5.3-4, Table 8.3-1, Table 8.3-2, Table 9.2-2, Table 9.2-3, and Table 12-1.
- OCHD2-4: The OCS2 SHALL comply with OCHD2-3 and the specifications described in Table 7.3-1 and Table 9.2-1.

4 SECURITY

This section describes requirements for copy protection of video programs, security of video streams, conditional access to video streams, and security of transmitted data.

4.1 Conditional Access

OCHD2-5: The OCHD2 SHALL utilize the CableCARD Device to perform the following Conditional Access functions as defined in [EIA-679-B]: CA decryption, authorization, entitlement and Copy Protection encryption. These functions SHALL be implemented in the CableCARD Device and not in the OCHD2. If conditional access functionality is present in the OCHD2, it SHALL be disabled under all circumstances, including the absence of a CableCARD Device.

4.2 Partitioning of Memory

OCHD2-6: Memory in the OCHD2 SHALL be partitioned such that separate partitions are maintained solely for the operation of CableLabs certified software and SHALL NOT be overwritten by any mechanism other than those specified in the [OC-CD] OpenCable Common Download Specification and the [OC-SEC] OpenCable System Security Specification. The CableLabs certified software in these partitions SHALL have sole access to the Out of Band channels.

4.3 Certificate Storage and Management

OCHD2-7: The OCHD2 SHALL store the various certificates and any associated private/public keys as defined in sections 5.8, 6.12, 6.1.3 and 6.1.6 of the OpenCable System Security Specification [OC-SEC].

4.4 Analog Program Copy Protection

OCHD2-8: The OCS2 SHALL be capable of adding analog copy protection to NTSC video outputs derived from digital programs in accordance with the [Macrovision] standard. The control of Macrovision mode SHALL be dictated by the APS bits of the CCI byte as defined in [CCCP2.0].

OCHD2-9: If the OCT2 includes analog video outputs, it SHALL be capable of adding analog copy protection to NTSC video outputs derived from digital programs in accordance with the [Macrovision] standard. The control of Macrovision mode is dictated by the APS bits of the CCI byte as defined in [CCCP2.0].

4.5 Digital Program Copy Protection

OCHD2-10: The [IEEE-1394] digital interface on the OCHD2 SHALL support both Full Authentication and Restricted Authentication copy protection requirements as defined by [DTCP].

OCHD2-11: The OCHD2 SHALL implement S-Mode or M-Mode copy protection as defined in the OpenCable CableCARD Copy Protection 2.0 Specification [CCCP2.0] in accordance with the conditions and dates specified in OCHD2-47a and OCHD2-47b.

OCHD2-12: The OCHD2 SHALL NOT change the CCI value used to control content output except as follows: 1) to Default CCI Value when a channel change occurs, 2) to a new authenticated CCI value received from the CableCARD Device, or 3) from Default CCI Value to Error CCI Value in the manner specified in [CCCP2.0].

OCHD2-13: The OCHD2 SHALL ignore any OCAP commands that would change the effect of CCI received from the CableCARD Device.

4.6 HD Copy Control

The following describe the requirements of the OCHD2 to ensure protection of HD content when required.

Control of copy control mechanisms on HD outputs is determined by the status of CCI bits. The cable operator determines the control policy through agreements between the operator and the content provider and asserts that policy with the CCI bits.

OCHD2-14: OCHD2s SHALL provide output control for Controlled Content on all outputs in accordance with specific instructions provided by the Monitor Application as defined in section 20 of [OCAP].

OCHD2-15a: OCHD2s SHALL have the functionality to allow the Monitor Application the ability to disable the outputs listed in [OCAP] as requiring control. That is, when the OCHD2 contains any of the following output ports,

- IEEE 1394
- Analog Component Video (Y,Pb,Pr)
- DVI
- HDMI
- any other outputs defined by OCAP specifications,

then the OCHD2 SHALL provide a means to enable and disable the program content stream out of these ports under OCAP software control.

OCHD2-15b: When an output port is disabled under software control, the OCHD2 SHALL provide a method to display a user message over this same port at the time the port is disabled for program content. The format and content of this message is unspecified.

NOTE 1: If the disabled port is the IEEE1394 output, then the OCHD2 MUST display the user message over all analog outputs and signal to the connected device via the External Jack Selection, as defined in [SCTE 26], that the analog port should be utilized. If the connected device does not support External Jack Selection, then the OCHD2 MUST display the user message on all analog output ports and NOT utilize External Jack Selection.

NOTE 2: The user message MUST be displayed for a period that shall not exceed 30 seconds.

OCHD2-16: If analog component video outputs are present, the OCHD2 SHALL provide a "Constrained Image" when the Constrained Image Trigger (CIT) bit in the CCI byte has a value equal to "1".

A Constrained Image as defined by the [CHILA] license agreement SHALL have the visual equivalent of not more than 520,000 pixels per frame; for example, an image of 960 (h) by 540 (v) pixels for a 16x9 aspect ratio.

OCHD2-17: When a Constrained Image is created by the OCHD2, it SHALL be sent to the analog component video interface with one of the scanning formats described in Table 1 of [CEA-770.3-C].

NOTE: This may require up-converting the Constrained Image via interpolation or line doubling in order to match one of the output scanning formats.

OCHD2-18: OCHD2s SHALL provide a method for software running on the Host Device, in particular the OCAP Monitor Application, to determine the status of copy control mechanisms on digital output ports. This includes the [DTCP] status of the IEEE-1394 port and the [HDCP] status of the DVI or HDMI port.

5 BI-DIRECTIONAL PHYSICAL LAYER CHARACTERISTICS

5.1 RF Interface

OCHD2-19: The mechanical and electrical interface between the cable plant and the OCHD2 SHALL be as defined in section 3 of [CEA-23] with the additional requirements specified in the remainder of this document.

5.1.1 Maximum Individual Carrier Amplitude

OCHD2-20: The OCHD2 SHALL be capable of meeting the FAT and FDC channel performance requirements in the presence of interfering signals where the maximum rms value of any individual interfering signal SHALL NOT exceed the following limits (measured across 75 Ω):

0.5 MHz to 42 MHz	+42 dBmV
42 MHz to 52 MHz	0 dBmV
52 MHz to 54 MHz	-17 dBmV

The maximum rms value of any individual signal whose frequency exceeds 54 MHz is less than +20 dBmV across a 75 ohm terminating impedance measured at the input to the Host Device.

5.2 Communication Channels

OCHD2-21: The OCHD2 SHALL have the following communication channels:

- Forward Application Transport (FAT) channels which carry MPEG-2 Program Streams or NTSC analog signals which may contain closed caption data in the Vertical Blanking Interval
- Forward Data Channel (OOB FDC)
- Reverse Data Channel (OOB RDC)
- DOCSIS downstream and upstream channels
- DSG tunnels using DOCSIS downstream channels

OCHD2-22: Frequency range for each downstream tuner or upstream transmitter SHALL be:

- 54 to 864 MHz (FAT channel and DOCSIS DSG downstream)
- 70 to 130 MHz (OOB FDC channel)
- 5 to 42 MHz (OOB RDC channel and DOCSIS upstream).

5.2.1 Forward Application Transport (FAT) Channel

The forward application transport channel is a 64 or 256 Quadrature Amplitude Modulation (QAM) channel according to [SCTE 07], that transports approximately 27 or 39 megabits/second, respectively. The OCHD2 is instructed to tune to a particular FAT channel when a subscriber requests a service that requires transport on a FAT channel. FAT channels that are present on the cable plant will adhere to the STD, HRC or IRC frequency plans of [CEA-542-B] and can be located anywhere in the 54 to 864 MHz range.

- OCHD2-23: The OCHD2 SHALL be capable of receiving and demodulating a Forward Application Transport channel with either 64 or 256QAM modulation.
- OCHD2-24: The OCHD2 SHALL be compliant with [SCTE 07] for the transmission physical layer modulation, coding, synchronization, and Forward Error Correction.
- OCHD2-25: The OCHD2 SHALL decode the Forward Application Transport channel over the range of input parameters as defined in Table 5.3-1.
- OCHD2-26: The Forward Application Transport tuner SHALL have a frequency range of 54 to 864 MHz or greater.

5.2.2 NTSC Analog Channels

- OCHD2-27: The OCHD2 SHALL receive all existing unscrambled analog channels that are NTSC RF AM-VSB modulated in accordance with applicable FCC rules.

NTSC analog channels will adhere to the STD, HRC or IRC frequency plans of [CEA-542-B] and can be located anywhere in the 54 to 864 MHz range.

5.2.2.1 Vertical Blanking Interval

The Vertical Blanking Interval (VBI) contains data on line 21 of an NTSC analog television signal. During this period, the headend can insert VBI data signals on line 21 for closed captioning. VBI data can be inserted within field 1, field 2 or both, on any analog channel operating in the 54 to 864 MHz range.

- OCHD2-28: The OCS2 SHALL include the capability to pass through to all NTSC analog video outputs closed caption information, text mode data services and extended data services data present on line 21 (field 1 and 2) of the VBI of received analog signals. The format of this data is defined in [47CFR15] and [CEA-608-B].
- OCHD2-28a: If such outputs are present, the OCT2 SHALL include the capability to pass through to all NTSC analog video outputs closed caption information, text mode data services and extended data services data present on line 21 (field 1 and 2) of the VBI of received analog signals. The format of this data is defined in [47CFR15] and [CEA-608-B].

5.2.3 Out-Of-Band Signaling

5.2.3.1 OOB-FDC and OOB-RDC

The RF front end provides the generic QPSK physical layer common to the OpenCable choices. These have the following characteristics:

Forward receiver:	1.544/3.088 Mbps and 2.048 Mbps
Reverse transmitter:	1.544/3.088 Mbps and 256 Kbps

Based on the network configuration, the Out-Of-Band Messaging for the OpenCable Host Device is implemented over the OOB-FDC / OOB-RDC communication channels or the DSG communication channel. The Out-Of-Band mode is communicated by the CableCARD Device to the Host via the CableCARD Interface.

- OCHD2-29: The OCHD2 SHALL be capable of receiving an Out-Of-Band Forward Data channel with parameters defined in OCHD2-30 and passing the demodulated signal to the CableCARD Device per [CCIF2.0].
- OCHD2-30: The OCHD2 SHALL be compliant with [SCTE 55-2] and [SCTE 55-1] for the OOB FDC and OOB RDC transmission physical layer modulation, coding, synchronization and Forward Error Correction.
- OCHD2-31: The OCHD2 SHALL demodulate the Out-Of-Band Forward Data Channel over the range of input levels as defined in Table 5.3-2.
- OCHD2-32: The Forward Data Channel tuner SHALL have a frequency range of 70 to 130 MHz and be able to tune any nominal carrier frequency defined in item 4 of Table 5.3-2, as directed by the CableCARD Device.
- OCHD2-33: The OCHD2 SHALL have an Out-Of-Band Reverse Data Channel QPSK transmitter used only under control of the CableCARD Device as specified in [SCTE 28].
- OCHD2-34: The OCHD2 SHALL transmit the Out-Of-Band Reverse Data Channel over the range of output levels as defined in Table 5.3-4.
- OCHD2-35: The Reverse Data Channel transmitter SHALL have a frequency range of 5 to 42 MHz.

5.2.3.2 DSG OOB Messaging

- OCHD2-36: Out-Of-Band Messaging for the OCHD2 using the DSG channel SHALL be implemented in accordance with [DSG] and [RFIv2.0].

NOTE: All Host 2.0 devices submitted after March 1, 2006, are required to support DOCSIS version 2.0.

5.3 Physical Layer Specifications

5.3.1 In-Band Downstream Channel, FDC Characteristics and RF Performance

- OCHD2-37: The OCHD2 SHALL meet all performance requirements specified in Table 5.3-1 and Table 5.3-2 while operating with the downstream transmission characteristics defined by [SCTE 40].
- OCHD2-38: The OCHD2 SHALL use a female "F" connector meeting [SCTE 01] for the RF input.
- OCHD2-39: The "F" connector for RF input on the OCHD2 SHALL be labeled "Cable In."

Table 5.3-1- Analog and FAT Channel: RF Performance Parameters (0° - 40° C)

	Parameter	Requirement
1.	RF Input Channel Bandwidth	6 MHz
2.	RF Input Tuning Range	54 MHz to 864 MHz IRC/HRC/STD Channel Plans
3.	RF Input Return Loss	6 dB minimum over full tuning range
4.	RF Input Impedance	75 ohm unbalanced
5.	RF Input Level Range	Analog visual carrier© from 0 dBmV minimum to +15 dBmV maximum; Analog aural carrier from -10 to -17 dBc; Digital QAM 64 signal from -15 dBmV to +15 dBmV; Digital QAM 256 signal from -12 dBmV to +15 dBmV
6.	AGC Range	NTSC baseband video output level variation of not more than ±1 dB with the analog visual carrier or digital QAM signal input level ranges stated above. (See Note 1)

	Parameter	Requirement
7.	AFC Range	Better than ± 125 kHz or nominal tuning resolution of 62.5 kHz
8.	LO Leakage (Input EMC)	-37 dBmV over 54 MHz to 864 MHz
9.	Conversion Isolation: RF Input to Converted RF Output	65 dB minimum; where isolation is defined here as the ratio between the converted signal and the unconverted signal present at the channel $\frac{3}{4}$ RF output. This parameter SHALL be met with the output measured on the same frequency as the input of the converter, and applies to all assigned input carrier frequencies over the input level range defined in 5 above. (See Note 2)
10.	RF Bypass Isolation	60 dB minimum over the input tuning range (54-864 MHz) when internal RF bypass option is installed. (See Note 2)
11.	CTB	Not worse than -63 dBc Channel loading assumptions: At least 110 AM-VSB channels at input level of +15 dBmV, at least 20 QAM channels at RF input level of +5 dBmV. (See Note 2)
12.	X-Mod.	Not worse than -57 dBc Channel loading assumptions: At least 110 AM-VSB channels at input level of +15 dBmV, at least 20 QAM channels at RF input level of +5 dBmV. (See Note 2)
13.	CSO	Not worse than -60 dBc Channel loading assumptions: At least 110 AM-VSB channels at input level of +15 dBmV, at least 20 QAM channels at RF input level of +5 dBmV. (See Note 2)
14.	Spurious Emissions within the output channel (channel $\frac{3}{4}$) bandwidth	Not worse than -60 dBc Channel loading assumptions: At least 110 AM-VSB channels at input level of +15 dBmV, at least 20 QAM channels at RF input level of +5 dBmV. (See Note 2)
15.	Spurious Emissions outside the output channel (other than channel $\frac{3}{4}$)	Not worse than -10 dBc (See Note 2)
16.	Signal Leakage/RFI	Per [47CFR15]
17.	AM Hum Modulation	Not greater than 3% p-p (See Note 2)
18.	Adjacent Channel Rejection	60 dB min (See Note 2)
19.	Group Delay Variation Tolerance	≤ 0.25 μ sec/MHz across the 6-MHz channel
20.	Phase Noise Tolerance	≤ -88 dB/Hz @ 10 kHz offset (relative to the center of QAM signal spectrum)
21.	Amplitude Ripple Tolerance	
	Digital channels	≤ 5 dB p-p within the 6 MHz channel
	Analog channels	≤ 4 dB p-p within the 6 MHz channel

	Parameter	Requirement
22.	Microreflection Tolerance (assumes one dominant echo with max. specified amplitude in dB relative to the primary QAM signal)	-10 dB at < 0.5 μ sec -15 dB at < 1 μ sec -20 dB at < 1.5 μ sec -30 dB at < 4.5 μ sec Echoes > 4.5 μ sec (see Note 3)
23.	Burst Noise Tolerance	Not longer than 25 μ sec at 10 Hz repetition rate
24.	Image Rejection (See Note 2)	Image response less than 60 dBc at final IF or baseband video output, 54 to 714 MHz Image response less than 50 dBc at final IF or baseband video output, 714 to 860 MHz 60dB standard to apply at 714 MHz Two equal power CW signals, +15 dBmV $F_{\text{image}} = F_{\text{desired}} + 90 \text{ MHz}$
25.	Spurious Emissions, 5 – 864 MHz	< -37 dBmV
<p><i>Table Notes:</i></p> <ol style="list-style-type: none"> 1. Applicable only when analog video outputs are provided. 2. Applicable only when converted RF outputs are provided. 3. Micro-reflection longer than 4.5 microseconds rarely occur in conventional cable television systems. Moreover, very low-level micro-reflections (e.g., -40dB) longer than 4.5 microseconds cannot be measured reliably with readily available instruments. Studies on the subject of long Micro-reflections are continuing, which may result in quantifying this parameter at a future date. 		

Table 5.3-2 - FDC Channel: RF Performance Parameters (0° - 40° C)

	Parameter	Requirement
1.	Transmission Rate	1.544/3.088 Mbps [SCTE 55-2] 2.048 Mbps [SCTE 55-1]
2.	RF Input Channel Spacing	1.0/2.0 MHz [SCTE 55-2] 1.8 MHz [SCTE 55-1]
3.	RF Input Tuning Range	70 MHz to 130 MHz
4.	Nominal carrier frequency	Any integer multiple of 250 kHz between the minimum and maximum carrier frequencies, inclusive and the specific fixed frequency of 104.200 MHz.
5.	Frequency acquisition range	+/- 50 ppm
6.	RF Input level range	-15 to +15 dBmV rms (75 ohms) (See Note 1)

	Parameter	Requirement
7.	Differential Encoding	The differential encoder SHALL accept bits (A, B) in sequence and generate phase changes as follows: A B Phase Change default alternative 0 0 none none 0 1 +90 deg -90 deg 1 0 -90 deg +90 deg 1 1 180 deg 180 deg
8.	Group Delay variation tolerance	200 ns max in channel, measured over Nyquist bandwidth
9.	Channel Tune / Carrier acquisition time	< 500ms
<i>Table Notes:</i> 1. See Section 5.3.1.1 for the variation in level between adjacent channels		

5.3.1.1 DOCSIS Downstream Channel

The downstream RF performance parameters for the eCM of the OpenCable Host Device are detailed in [RFIV2.0].

5.3.1.2 RF Signal Levels and Adjacent Channel Characteristics

5.3.1.2.1 RF Signal Levels

OCHD2-40: The OCHD2 SHALL be capable of receiving an analog signal with a visual signal level that is within ± 3 dB of the visual signal level of any adjacent analog channel (within a 6 MHz nominal frequency separation as specified in [47CFR76].

To determine the adjacent channel characteristics between digital and analog signals, the following information is provided. The nominal relative carrier power levels for analog and digital signals are given by:

- Analog channel: 0 dBc (reference level)
- 256 QAM FAT: -5 ± 2 dBc
- QPSK FDC: -8 ± 5 dBc
- 64 QAM FAT: -10 ± 2 dBc

OCHD2-41: The OCHD2 SHALL be capable of receiving a digital signal with an average RMS signal power that is within ± 6 dB of its nominal level with respect to the nominal level of the adjacent channel digital or analog signal.

It is noted that the nominal carrier power levels provided above fall within the absolute power range for digital signals, -15 dBmV to +15 dBmV. The nominal analog signal power is measured as the peak envelope power (PEP), which is the average of all the analog RMS carrier power levels measured during horizontal sync level. The nominal digital signal power is measured as the average of all the digital RMS signal power levels.

5.3.1.2.2 Adjacent Channel Characteristics

OCHD2-42: The OCHD2 SHALL be capable of receiving digital and analog signals with "Worst Case" Adjacent Channel performance as characterized in Table 5.3-3.

Table 5.3-3 - Adjacent Channel Characteristics

	Desired (D) Channel Modulation	Undesired (U) Adjacent Channel Modulation	Worst Case D/U Ratio*
1.	Analog NTSC	64-QAM	-1 dB
2.	Analog NTSC	256-QAM	-6 dB
3.	Analog NTSC	QPSK FDC	-6 dB
4.	64-QAM	Analog NTSC	-21 dB
5.	64-QAM	256-QAM	-21 dB
6.	64-QAM	QPSK FDC	-21 dB
7.	256-QAM	Analog NTSC	-16 dB
8.	256-QAM	64-QAM	-11 dB
9.	256-QAM	QPSK FDC	-16 dB
10.	QPSK FDC	Analog NTSC	-22 dB
11.	QPSK FDC	64-QAM	-17 dB
12.	QPSK FDC	256-QAM	-22 dB

* Independent of the D/U ratios, the C/(N+I) and the absolute signal levels range shall meet the requirements for those parameters as described elsewhere in the specification.

5.3.1.2.3 Ranges for Digital Signals

OCHD2-43: Independently of meeting the requirements specified in Sections 5.3.1.2.1 and 5.3.1.2.2 above, the OCHD2 SHALL tune and receive digital signals that fall within the ranges specified in Table 5.3-1 (QAM signals) and Table 5.3-2 (QPSK FDC signals).

OCHD2-44: Independently of meeting the requirements listed in 5.3.1.2.1 and 5.3.1.2.2 the OCHD2 SHALL be capable of receiving digital 64QAM with characteristics:

- 1) Level = -10 dBmV on channel 82
- 2) Interleaver depth of greater than or equal to I=64 (J=2)
- 3) 33 dB C/N
- 4) -18 dB ghost at 0.5 us
- 5) 25 us burst noise not greater than -15 dBmV at 10 Hz rep rate

OCHD2-45: Independently of meeting the requirements listed in 5.3.1.2.1 and 5.3.1.2.2, the OCHD2 SHALL be capable of receiving digital 256QAM with characteristics:

- 1) Level = -7 dBmV on channel 82
- 2) Interleaver depth of greater than or equal to I=64 (J=2)
- 3) 36 dB C/N
- 4) -18 dB ghost at 0.5 us
- 5) 16 us burst noise not greater than -12 dBmV at 10 Hz rep rate

	Parameter	Values for OOB-RDC
17.	Level absolute accuracy	< +/- 2 dB
18.	Level flatness, 5 - 42MHz	< 2 dB
19.	Spurious outputs, 5 - 42 MHz	< -45 dBc
20.	Harmonic outputs, 10 - 42MHz	< -45 dBc
21.	Out-of-band spurious and harmonics, 54 – 864 MHz	< -37 dBmV
22.	Noise Power Density, as measured +/- $f_w/2$ from center channel frequency, where f_w is the channel spacing. Carrier level > 35 dBmV	> 113 dBc in 1 Hz
23.	Noise Power Density, 5 to 42 MHz when transmitter is idle	< - 105 dBmV (1 Hz) 75 ohms
24.	Return Loss, 75 ohms, 5 to 14 MHz 14 to 26 MHz 26 to 42MHz	> 9 dB > 11 dB > 6 dB

6 CABLECARD INTERFACE

The OCHD2 provides an interface to the CableCARD Device to facilitate the processing of digital information received over the forward application transport (FAT) channel and the OOB forward data channel (FDC) or the OOB channel using the DOCSIS Set-top Gateway DSG tunnels [DSG]. The interface between the OCHD2 and the CableCARD Device are described in [CCIF2.0].

- OCHD2-47a: Effective 3/23/2006 (Certification Wave 43), all Host 2.0 device submissions SHALL only implement the Host side of the Multi-Stream CableCARD Interface according to [CCIF2.0], except for those COMPANIES which have a product certified prior to CW 43, in which case the Single-Stream Interface is permitted on models through Certification Wave 47.
- OCHD2-47b: Effective Certification Wave 49 (2007) all Host 2.0 device submissions SHALL only implement the Host side of the Multi-Stream CableCARD Interface according to [CCIF2.0].
- OCHD2-48: The OCHD2 SHALL be required to support transport stream interface data rates of 26.97035 Mb/s and 38.81070 Mb/s averaged over the period between the sync bytes of successive transport packets with allowable jitter of ± 1 MCLKI clock period.
- OCHD2-49: The OCHD2 SHALL implement all aspects of the Host operation specified in section 8.13 of [SCTE 28].
- OCHD2-50: The OCHD2 SHALL report a Low_Speed_Communication Resource Identifier of 0x00608043 for a Host with an OOB RDC Channel and a DOCSIS return channel.

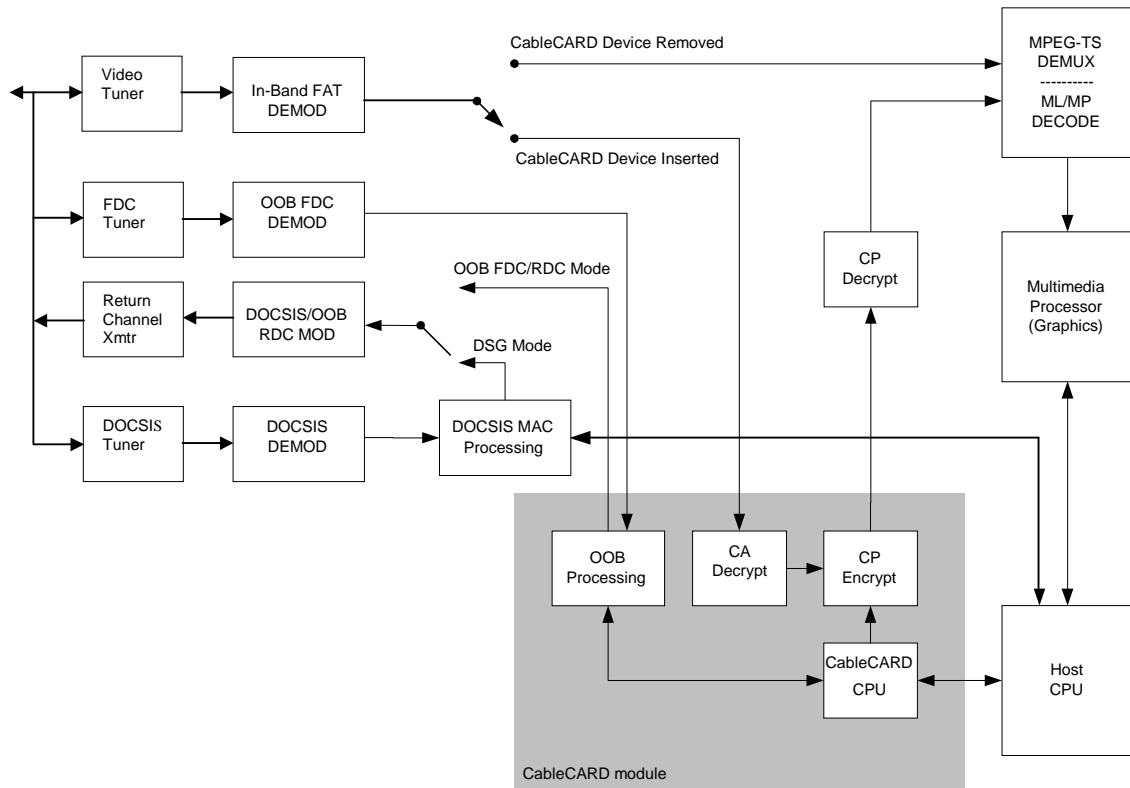

Figure 6–1 - Block Diagram of the OpenCable CableCARD Interface (Informative)

6.1 OpenCable Host Device 2 Functionality without a CableCARD Device

The OCHD2 will function without a CableCARD Device and process the analog or digital signals received via the FAT channels directly. The Host will have the following minimum functional characteristics without the CableCARD Device:

- OCHD2-51: The OCS2 SHALL demodulate and output unscrambled analog NTSC audio-visual programming transported according to STD, HRC or IRC frequency plans as specified in [CEA-542-B].
- OCHD2-52: The OCT2 SHALL demodulate and display unscrambled analog NTSC audio-visual programming transported according to STD, HRC or IRC frequency plans as specified in [CEA-542-B].
- OCHD2-53: The OCS2 SHALL discover, decode and output unscrambled digital standard definition and high definition audio-visual programming conforming to MPEG-2 Main Profile @ Main Level or Main Profile @ High Level and Dolby AC-3 audio as specified in Table 3 of [SCTE 43] and transported in adherence to STD, HRC or IRC frequency plans as specified in [CEA-542-B].
- OCHD2-54: The OCT2 SHALL discover, decode and display unscrambled digital standard definition and high definition audio-visual programming conforming to MPEG-2 Main Profile @ Main Level or Main Profile @ High Level and Dolby AC-3 audio as specified in Table 3 of [SCTE 43] and transported in adherence to STD, HRC or IRC frequency plans as specified in [CEA-542-B].
- OCHD2-55a: When the OCHD2 is operating without a CableCARD Device and is tuned to a digital transport stream containing multiple programs, each program SHALL be identified by the one-part channel number identified in the CVCT delivered in the in-band PSIP [A/65B] stream, if present.
- OCHD2-55b: Each program SHALL be identified by the two-part channel number if the one-part channel number is not present in the CVCT.
- OCHD2-56: When the OCHD2 is operating without a CableCARD Device and is tuned to a digital transport stream containing multiple programs each program SHALL be identified by the two-part channel number identified in the TVCT in the absence of the CVCT delivered in the in-band PSIP [A/65B] stream, if present.
- OCHD2-57: When the OCHD2 is operating without a CableCARD Device, any channel map created from OOB data while previously operating with a CableCARD Device SHALL not be used.
- OCHD2-58: When the OCHD2 is operating without a CableCARD Device, the OCHD2 SHALL disable the Reverse Data Channel (RDC) transmit function.

6.2 Man Machine Interface (MMI) Support

The OCHD2 will be capable of operating in a unidirectional system and will support copy protection in this operational case. As defined in the OpenCable Copy Protection 2.0 Specification [CCCP2.0] for a unidirectional system, the copy protection system performs authorization utilizing the MMI resource.

- OCHD2-59: The OCHD2 SHALL support the MMI resource defined in [CCIF2.0].
- OCHD2-60: The OCHD2 SHALL support a navigation method to allow user navigation with the MMI resource defined in [CCIF2.0].

6.3 Software

6.3.1 Middleware

OCHD2-61: The OCHD2 SHALL contain a certified implementation of [OCAP].

6.3.2 Software Download

OCHD2-62: The OCHD2 SHALL support the download of software based on the transfer protocols and security systems of DOCSIS and OpenCable as specified in [BPI+] and [OC-CD].

OCHD2-63: The OCHD2 SHALL support upgrade of the following code images:

- embedded Cable Modem (eCM) code including DSG functionality
- OCAP implementation including any underlying Operating System (OS)
- Persistent applications such as the Navigation system

by mechanisms specified in [OC-CD] in a manner that does not compromise the integrity of the separate functional components. For example, an upgrade to DSG functionality must not effect the behavior of the OCAP environment or persistent applications.

Note: This may involve upgrading both DSG and other functional components together in one download or separating the functions in a manner that protects one component from the effects of upgrading the other components.

OCHD2-64: The OCHD2 SHALL support the following code upgrade options:

- independent upgrade of each image
- upgrade of some or all images via a single monolithic code image

OCHD2-65: The OCHD2 SHALL have the capability to verify digital signatures on individual code images when each is independently signed by different co-signers.

6.3.3 Specific Application Support Resource

OCHD2-66: The OCHD2 SHALL support the Specific Application Support Resource defined in [CCIF2.0].

6.4 Extended Channel Support

In order for OCAP enabled devices to support IP Unicast, the OCHD2 is required to have a unique MAC address specifically assigned to support IP Unicast over the CableCARD Interface. The MAC address will be utilized by the headend as a means to associate a requested IP address with the OCHD2.

OCHD2-67: The OCHD2 SHALL have a unique 48-bit MAC address specifically assigned to support IP Unicast over the CableCARD Interface.

OCHD2-68: The first 24 bits of the MAC address SHALL consist of an Organizationally Unique Identifier (OUI) assigned to an OCHD2 vendor by the IEEE.

OCHD2-69: The remaining 24 bits of the MAC address SHALL consist of a unique 24-bit value that is generated by the OCHD2 vendor.

OCHD2-70: The OCHD2 SHALL not utilize the MAC address of the IEEE-1394 interface for the MAC address used for IP Unicast support.

OCHD2-71: The OCHD2 SHALL support at least six concurrent MPEG_section Service_type flows.

OCHD2-72: The OCHD2 SHALL support at least one IP_U Service_type flow.

OCHD2-73: The OCHD2 SHALL support one DSG Service_type flow.

7 MULTI-MEDIA INTERFACES

7.1 OpenCable Host Device 2 Outputs

The required outputs from the OCS2 are shown schematically in Figure 3.1–1 and detailed below. Some of the outputs shown Figure 3.1–1 are optional for the OCT2. Copy protection will be applied as applicable to any of optional interfaces as defined in OCHD2-8 through OCHD2-18 above. Copy protection signaling is described in the OpenCable CableCARD Copy Protection 2.0 Specification [CCCP2.0].

- OCHD2-74a: The OCS2 SHALL have a RF-modulated output compliant with Table 7.3-1, Table 8.3-1, Table 8.3-2 and Table 9.2-1 which may be subscriber configurable to analog NTSC channel 3 or 4 if allowed by the parameters in the Generic Feature resource defined in [CCIF2.0].
- OCHD2-74b: The default channel setting for the RF-modulated output SHALL be configurable by the cable operator using the Generic Feature resource defined in [CCIF2.0].
- OCHD2-75a: If the OCT2 includes a RF-modulated output, it SHALL be compliant with Table 7.3-1, Table 8.3-1, Table 8.3-2 and Table 9.2-1 which may be subscriber configurable to analog NTSC channel 3 or 4 if allowed by the parameters in the Generic Feature resource defined in [CCIF2.0].
- OCHD2-75b: The default channel setting for the RF-modulated output, if present, SHALL be configurable by the cable operator using the Generic Feature resource defined in [CCIF2.0].
- OCHD2-76: The OCS2 SHALL use a female "F" connector in compliance with [SCTE 01] for the RF-modulated output.
- OCHD2-77: If the OCT2 includes a RF-modulated output, it SHALL use a female "F" connector in compliance with [SCTE 01].
- OCHD2-78: The "F" connector for a RF-modulated output SHALL be labeled "To TV / VCR".
- OCHD2-79: The OCS2 SHALL provide composite baseband video as defined by Table 8.3-1 and Table 8.3-2 and L&R baseband audio outputs as defined by Table 9.2-2 and Table 9.2-3.
- OCHD2-80: If the OCT2 includes outputs, the Device SHALL provide composite baseband video as defined by Table 8.3-1 and Table 8.3-2 and L&R baseband audio outputs as defined by Table 9.2-2 and Table 9.2-3.
- OCHD2-81: The OCS2 SHALL use a female RCA phono connector for composite baseband video output.
- OCHD2-82: If the OCT2 includes a composite baseband video output, it SHALL use a female RCA phono connector.
- OCHD2-83: The RCA phono connector for composite baseband video output on the OCS2 SHALL have a yellow dielectric. This connector SHALL be labeled "Video" or "Video Out".
- OCHD2-84: If the OCT2 includes a composite baseband video output, the RCA phono connector SHALL have a yellow dielectric. This connector SHALL be labeled "Video" or "Video Out".
- OCHD2-85: The OCS2 SHALL include a S-Video output that uses a female 4-pin Mini DIN connector.
- OCHD2-86: If the OCT2 includes a S-Video output, it SHALL use a female 4-pin Mini DIN connector.
- OCHD2-87: The 4-pin Mini DIN connector for S-Video output SHALL be labeled "S-Video".
- OCHD2-88: The OCS2 SHALL use female RCA phono connectors for left and right audio outputs.
- OCHD2-89: If the OCT2 includes audio outputs, it SHALL use female RCA phono connectors for left and right audio outputs.
- OCHD2-90a: The RCA phono connector for the right audio output SHALL have a red dielectric.

- OCHD2-90b: This connector SHALL be labeled to indicate the function of right audio output, for example: "R", "Right" or "Right Audio".
- OCHD2-91a: The RCA phono connector for the left audio output SHALL have a white dielectric.
- OCHD2-91b: This connector SHALL be labeled to indicate the function of left audio output, for example: "L", "Left" or "Left Audio".
- OCHD2-92: The OCS2 SHALL use a female RCA phono connector, [IEC 61937] optical connector or both, for the S/P DIF audio output.
- OCHD2-93: If the OCT2 includes a S/P DIF audio output, it SHALL use a female RCA phono connector, an [IEC 61937] optical connector or both.
- OCHD2-94: The connector for the S/P DIF audio output SHALL be labeled to indicate the function; for example "Digital Audio Output".
- OCHD2-95: In order to support connections to multiple devices via the IEEE-1394 bus, the OCS2 SHALL provide at least two 4-pin or 6-pin standard 1394 connectors operated as a source device. Both connectors SHALL have the same number of pins.
- OCHD2-96: In order to support connections to multiple devices via the IEEE-1394 bus, the OCT2 SHALL provide at least two 4-pin or 6-pin standard IEEE-1394 connectors operated as a sink device. Both connectors SHALL have the same number of pins.

7.2 OpenCable Host Input Devices

- OCHD2-97: The OCHD2 SHALL be accompanied by one or more input devices. At least one input device SHALL support all of the required keys identified in [OCAP] Table 25-2. The four function keys SHALL be identified as shown in Table 7.2-1. The keys corresponding to certain KeyEvents SHALL be labeled as shown in Table 7.2-2. The physical layout and placement of any particular key is not specified and can be determined by the manufacturer.

Table 7.2-1 – Function Key Shapes and Colors

Function Key	Shape	Color
Function Key 0	Circle	Red: Pantone 200
Function Key 1	Star or diamond	Green: Pantone 355
Function Key 2	Square	Blue: Pantone 300
Function Key 3	Triangle	Yellow: Pantone 803

Table 7.2-2 – Key Event Labels

KeyEvent	Key Label
VK_ENTER	Select
VK_GUIDE	Guide
VK_MENU	Menu
VK_INFO	Info
VK_EXIT	Exit
VK_LAST	Last
VK_NEXT_FAVORITE_CHANNEL	Favorite
VK_ON_DEMAND	On Demand

- OCHD2-97b: The OCHD2 SHALL include any one of the following three methods to provide support for a wireless keyboard to be used as an input device.
- Supply a keyboard that supports all of the keys identified in Table 25-3 of [OCAP].
 - Do not supply a keyboard and provide details on either (a) the exact codes and protocol that are used by the wireless receiver in the Host device, with a release that allows 3rd party vendors to build a compatible keyboard or (b) identify the licensable wireless protocol that 3rd party vendors can implement (with or without disclosing the details of the codes and protocols). Support for all keys identified in Table 25-3 of [OCAP] SHALL be required.
 - Do not supply a keyboard and implement an IR receiver that is compatible with an IR protocol that CableLabs specifies. The exact codes and protocols are to be determined.

7.3 RF Output Requirements (Channel $\frac{3}{4}$ RF Output)

Table 7.3-1 - Channel $\frac{3}{4}$ RF Output Performance Parameters (0° - 40° C)

	Parameter	Requirement
1.	RF Output Carrier Frequencies	Channels 3 & 4 STD
2.	RF Output Impedance	75 ohm, unbalanced
3.	RF Output Return Loss	Ch $\frac{3}{4}$ RF output: 10 dB minimum for either channel
4.	Ch $\frac{3}{4}$ RF Output Level	+4.5 dBmV to +15 dBmV
5.	Ch $\frac{3}{4}$ RF Output Level Stability	Not vary more than ± 1.5 dB
6.	Output Visual Carrier Frequency Accuracy	Within ± 80 kHz or better
7.	Output Video Frequency Response for RF Output (worst case for analog NTSC or digital MPEG input signals)	-2 to +2 dB, -500 kHz to 3.75 MHz
8.	Terminal Contribution to Output Frequency Response for RF Output (worst case for analog NTSC or digital MPEG input signals)	-1 to +1 dB, -500 kHz to 3.75 MHz
9.	Output Visual/Aural Carrier Level Difference	Aural carrier is -10 to -17 dB relative to visual carrier level
10.	Output Visual/Aural Carrier Frequency Separation	4.5 MHz, ± 5 kHz
11.	Output Depth of Modulation	85%, with variation not more than +5% to -2.5%
12.	Modulation Variation with APL	Not more than $\pm 5\%$, relative to 50% APL over 10 % to 90% APL range
13.	Conversion Isolation: RF Input to Converted RF Output	65 dB minimum; where isolation is defined here as the ratio between the converted signal and the unconverted signal present at the channel $\frac{3}{4}$ RF output. This parameter SHALL be met with the output measured on the same frequency as the input of the converter, and applies to all assigned input carrier frequencies over the input level range defined in 5 above.
14.	RF Bypass Isolation	60 dB minimum over the input tuning range (54-864 MHz) when internal RF bypass option is installed
15.	Spurious Emissions within the output channel (channel $\frac{3}{4}$) bandwidth	Not worse than -60 dBc Channel loading assumptions: At least 110 AM-VSB channels at input level of +15 dBmV, at least 20 QAM channels at RF input level of +5 dBmV.
16.	Spurious Emissions outside the output channel (other than channel $\frac{3}{4}$)	Not worse than -10 dBc
17.	AM Hum Modulation	Not greater than 3% p-p

8 VIDEO

8.1 Analog Video

The OCHD2 will be introduced into an environment containing many existing analog set-top devices. The OCHD2 will be able to receive analog services that are unscrambled. Analog video and audio will be NTSC-decoded in accordance with current cable-system practice and applicable FCC rules.

8.1.1 Analog Tuning

OCHD2-98: The OCHD2 SHALL have the capability to tune and demodulate NTSC-encoded channels from 54 to 864 MHz according to the STD, IRC, and HRC channel plans as defined in [CEA-542-B].

8.2 Digital Video

The OCHD2 is required to handle digital transport streams according to the following requirements:

8.2.1 MPEG-2 Transport

- OCHD2-99: The OCHD2 SHALL be able to process MPEG-2 compliant Transport Streams in accordance with [SCTE 54].
- OCHD2-100: The OCHD2 SHALL support System Information tables provided in [SCTE 65] for the navigation function.
- OCHD2-101: The OCHD2 SHALL be capable of acquiring and displaying a Digital Service contained within the same multiplex within 1.5 seconds, worst case. The nominal acquisition and display target time SHALL be within 1.0 seconds. Network conditions in which these values are valid are defined in the OpenCable Host Device Acceptance Test Plan. The nominal and worst-case acquisition and display times of the OCHD2 will be certified using a vendor-provided navigation tool.
- OCHD2-102: The OCHD2 SHALL be capable of acquiring and displaying a Digital Service contained within a different multiplex within 2.0 seconds, worst case. The nominal acquisition and display time SHALL be within 1.0 seconds. Network conditions in which these values are valid are defined in the OpenCable Host Device Acceptance Test Plan. The nominal and worst-case acquisition and display times of the OCHD2 will be certified using a vendor-provided navigation tool.
- OCHD2-103: The System Information tables (e.g., NTT, NIT and VCT) required to build the video channel map used for program navigation SHALL be stored in non-volatile memory in the OCHD2.

8.2.2 Digital Video Decoding

- OCHD2-104: The MPEG-2 decoder within the OCHD2 SHALL be able to decode all MPEG-2 formats in Table 3 of [SCTE 43].
- OCHD2-105: The OCHD2 SHALL be able to convert the decoded picture to the selected resolution of any supported output interface.
- OCHD2-106: The OCHD2 SHALL decode MPEG-2 Main Profile @ Main Level and Main Profile @ High Level per [ISO 13818-2] with the constraints and extensions that apply to video as specified in [A/53C].
- OCHD2-107: The OCS2 SHALL decode MPEG-2 video with resolutions shown in Table 3 of [SCTE 43].

OCHD2-108: The OCT2 SHALL decode MPEG-2 video with resolutions shown in Table 3 of [SCTE 43] with the following condition:

The resolution of the displayed image will be at the option of the OCT2 manufacturer.

OCHD2-109: The OCS2 SHALL decode MPEG-2 video with aspect ratios listed in Table 3 of [SCTE 43].

OCHD2-110: The OCT2 SHALL decode MPEG-2 video with aspect ratios as shown in Table 3 of [SCTE 43] with the following conditions:

- The aspect ratio of the displayed image will be at the option of the OCT2 manufacturer.
- As a minimum, user options to select letterbox and cropping of pictures that do not match the aspect ratio of the display device SHALL be provided.

OCHD2-111: The OCHD2 MPEG-2 decoder SHALL support decoding of an MPEG-2 Main Profile @ High Level Single Program Transport Stream encoded at a constant bit rate (CBR) of 38.81070Mbps or variable bit rate (VBR), with peak rates up to 38.81070Mbps, the maximum payload rate for a 256QAM channel.

OCHD2-112: The OCHD2 MPEG-2 decoder SHALL support error concealment to minimize macroblock and stream synchronization errors.

NOTE: Standard test streams with known errors will be used to evaluate error concealment implementations.

8.2.3 Digital Television (DTV) In-Band Service/System Information

OCHD2-113: When the OCHD2 is operating without a CableCARD Device the OCHD2 SHALL process in-band System and Service Information for programs that are transported unscrambled in accordance with section 5.5 of [SCTE 54].

8.2.4 Digital Television (DTV) Out-of-Band Service/System Information

OCHD2-114: The OCHD2 SHALL process out-of-band System and Service Information that is sent across the CableCARD interface in Extended Channel data flows, using Service_type = MPEG_section, as defined in [CCIF2.0] and [SCTE 65].

The set of MPEG-2 tables required to support the navigation function in the OCHD2 conforms to one or more of the profiles specified in [SCTE 65].

OCHD2-115: The OCHD2 SHALL be able to extract the channel map used for program navigation from all profiles specified in [SCTE 65].

8.2.5 Digital Television (DTV) Closed Captioning

OCHD2-116: The OCS2 SHALL extract NTSC closed captioning information when present in the MPEG-2 Picture Level user_data as specified in section 4 of [EIA 708B] or as specified in [CEA-608-B] and transported according to [SCTE 21] or [SCTE 20]. This will include all data of *cc_type* 00 and 01, as defined in [47CFR15] and [CEA-608-B]. The OCS2 SHALL reconstruct line 21 VBI (both field 1 and field 2) according to [CEA-608-B] on all NTSC analog video outputs.

NOTE: Other closed captioning and extended data structures may be present in the MPEG-2 Picture Level user_data.

- OCHD2-117: If the OCT2 includes NTSC analog video outputs, it SHALL extract NTSC closed captioning information, when present in the MPEG-2 Picture Level user_data, as specified in section 4 of [EIA 708B] or as specified [CEA-608-B] and transported according to [SCTE 21] or [SCTE 20]. This will include all data of *cc_type* 00 and 01, as defined in [47CFR15] and [CEA-608-B]. The OCT2 SHALL reconstruct line 21 VBI (both field 1 and field 2) according to [CEA-608-B] on all NTSC analog video outputs.
- OCHD2-118: If the OCS2 provides analog component or uncompressed digital video outputs, decoding of the NTSC caption data SHALL be provided according to [47CFR15].
- OCHD2-119: If the OCT2 provides analog component or uncompressed digital video outputs, decoding and display of the NTSC caption data SHALL be provided according to [47CFR15].
- OCHD2-120: The OCS2 SHALL extract the Digital Television closed captioning (DTVCC) information when present in the MPEG-2 Picture Level user_data, as specified in section 9 of [EIA 708B] and delivered according to [A/53C] (with *cc_type* set to '10' or '11'). This caption data SHALL be passed through to a DTV display via the IEEE-1394 interface.
- OCHD2-121: If the OCHD2 provides an NTSC analog video output, and the network stream dual carries [CEA-608-B] caption data transported according to [SCTE 21] or [SCTE 20], then the OCHD2 SHALL reconstruct line 21 VBI in the NTSC analog video output as required by [47CFR15].
- OCHD2-122: In the case where an MPEG Picture Level user_data field includes data formatted and transported according to [SCTE 21] or [SCTE 20], the OCHD2 MAY use closed captioning data recovered from either method.
- OCHD2-123: The OCHD2 SHALL process the *caption_service_descriptor*, when present, as defined in [A/65B] and carried in either the PMT of the in-band MPEG-2 transport stream or passed across the CableCARD Extended Data Channel according to [CCIF2.0].

8.2.6 Digital Television (DTV) Content Advisory Information

To support the interoperable availability of content advisory information for Host Devices and/or CableCARD Devices, OpenCable specifies the use of MPEG-2 Picture Level user_data found in [SCTE 21], the *content_advisory_descriptor* passed across the CableCARD Extended Data Channel, or the *content_advisory_descriptor* found in section 6.7.4 of [A/65B]. The syntax follows Table 6.18 in that reference. This descriptor is placed in the Program Map Table (PMT) as permitted in Table 6.16 of [A/65B] in accordance with the standard descriptor mapping for the *TS_program_map_section()* found in [ISO 13818-1].

The only rating region currently defined for OpenCable use is Region One (value 0x01 for the *rating_region* field). Semantics for the coding of the fields found in the PSIP Content Advisory Descriptor follow the rules given in section 6.74 of [A/65B].

- OCHD2-124: The OCS2 SHALL extract content advisory information as specified in [CEA-608-B] when such information is transported according to [SCTE 21] or [SCTE 20].
- OCHD2-125: If the OCT2 includes NTSC analog video outputs, it SHALL extract content advisory information as specified in [CEA-608-B] when such information is transported according to [SCTE 21] or [SCTE 20].
- OCHD2-126: The OCHD2 MAY extract content advisory information from the *content_advisory_descriptor* as defined in [A/65B] and [CEA-766-A] when such information is transported in the PMT of the in-band MPEG-2 transport stream or passed across the CableCARD Extended Data Channel according to [CCIF2.0].
- OCHD2-127: Digital video streams transmitted from a OCS2 to a DTV receiver via the IEEE-1394 interface SHALL contain content advisory information, when such information is present in the received signal.

- OCHD2-128: If the OCT2 includes an IEEE-1394 interface operated as a source device, digital video streams transmitted out of this interface SHALL contain content advisory information, when such information is present in the received signal.
- OCHD2-129: The OCS2 SHALL reconstruct line 21 of the NTSC analog video output using the content advisory information as specified in [CEA-608-B], when such information is present in the received signal.
- OCHD2-130: If the OCT2 includes NTSC analog video outputs, it SHALL reconstruct line 21 of the NTSC analog video output using the content advisory information as specified in [CEA-608-B], when such information is present in the received signal.
- OCHD2-131: If the OCHD2 includes analog component or uncompressed digital video outputs it SHALL decode content advisory information as defined in [CEA-608-B] and required by [47CFR15].
- OCHD2-132: The OCHD2 SHALL have *a priori* knowledge of the U.S. RRT (Region Rating Table for Region One) that is defined in [CEA-766-A] (i.e., the table is stored in the OCHD2).
- OCHD2-133: The U.S. RRT SHALL be the default RRT for all OCHD2s. It is noted that this approach is consistent with that specified in Annex C.1 of [SCTE 65].

8.2.7 Digital Television (DTV) Emergency Alert Service (EAS)

The OCHD2 processes emergency messages that utilize the EAS message syntax, which is compatible with MPEG-2 transport and is defined in [SCTE 18]. For in-band transmission, it appears in the transport packet with the same PID as those used for Service/System Information (SI). The table ID for the EAS message is 0xD8 as defined in [SCTE 18]. For out-of-band (OOB) transmission, the EAS message is transmitted according to [SCTE 18].

- OCHD2-134: The OCHD2 SHALL process EAS messages, when received, as defined in [SCTE 18].

8.3 Video Performance Specifications

- OCHD2-135: The OCHD2 SHALL meet all performance requirements specified in Table 8.3-1 and Table 8.3-2.

NOTE: Each line item parameter in Table 8.3-1 applies to both baseband and RF-modulated output video unless otherwise stated.

Table 8.3-1 - Composite Analog Video Output Performance Parameters (0 °- 40° C)

	Parameter	Requirement
1.	Video Standard	NTSC composite, EIA-563
2.	Signal Level (composite video)	1.0 volt peak-to-peak, sync tip (-40 IRE) to reference white (100 IRE) $\pm 10\%$
3.	Long Time Distortion (Bounce)	$\pm 1\%$, settle in less than 1 second
4.	Field Time Distortion	$\pm 4\%$
5.	Line Time Distortion	Baseband: $\pm 2\%$, RF Modulated: ± 3
6.	Short Time Distortion	$\pm 6\%$ (Rising and/or Falling)
7.	Chroma to Luminance Gain Inequality	Not more than $\pm 10\%$ (+30% to -50% for OCT2s)
8.	Chroma to Luminance Delay for Baseband Video Output (box only, not including headend and plant)	≤ 100 nsec (AM-VSB analog)
9.	Frequency Response for Baseband Video Output (worst case for analog NTSC or digital MPEG input signals)	-2 to +2 dB, 0 kHz to 3.75 MHz (+2 to -6 dB for OCT2s).
10.	Terminal Contribution to Output Frequency Response for RF Output (worst case for analog NTSC or digital MPEG input signals)	-1 to +1 dB, 0 kHz to 3.75 MHz
11.	Luminance Non-Linearity	5% p-p maximum
12.	Chroma Non-Linear Phase Distortion	$\pm 5^\circ$
13.	Chroma Non-Linear Gain Distortion	$\pm 5\%$
14.	Chroma/Luma Intermod	$\pm 3\%$
15.	Differential Gain (over 10% to 90% APL range)	10% peak to peak max. for RF modulated output; 5% peak to peak max. for baseband video output
16.	Differential Phase (over 10% to 90% APL range)	10° peak to peak max. for RF modulated output; 5° peak to peak max. for baseband video output
17.	920 kHz Beat	-52 dBc
18.	Video Signal-to-Noise Ratio (over the full input tuning range)	For RF Modulated Output: 53 dB with a digital input signal and 48 dB with an analog input signal at 0 dBmV (51 dB and 44 dB, respectively, for Terminal Devices). (Note 1) For Baseband Video Output: 57 dB with a digital input signal and 49 dB with an analog input signal at 0 dBmV (55 dB and 45 dB, respectively, for Terminal Devices). (Note 1)
19.	Baseband Video Output Impedance	75 ohm $\pm 10\%$
20.	Baseband Video Output Return Loss	16 dB minimum across video bandwidth
<i>Table Notes:</i>		
1. Video SNR measured with Unified Weighting filter.		

Table 8.3-2 - Analog Video Output Performance when processing a digital video program source (0°- 40° C)

	Parameter	Requirement
1.	Bar Level (rel. Back Porch)	100 IRE nominal
2.	Sync Polarity	Negative (normal)
3.	Sync Level (rel. Back Porch)	40 IRE \pm 4
4.	Color Burst Amplitude	40 IRE \pm 4
5.	Color Burst Duration	2.5 microseconds = 9 cycles \pm 1 (EIA RS-170)
6.	Front Porch Duration	1.4 microseconds minimum (+4 IRE to -20 IRE)
7.	Sync to Setup Duration	8.5 microseconds minimum (-20 IRE to +4 IRE)
8.	Horizontal Blanking Duration	10.9 microseconds, \pm 0.3 microseconds (+4 IRE to -4 IRE)
9.	Sync Pulse Duration	4.7 microseconds, \pm 0.2 microsecond (50% width)
10.	Sync Pulse Rise Time	140 nsec \pm 30 nsec (10% to 90% amplitude)
11.	Equalization Pulse	2.3 microseconds \pm 0.2 (50% width)
12.	Vertical Pulse	(H/2 - 4.7 microsecond) \pm 0.2 (50% width)
13.	Breezeway Duration	0.6 microseconds
14.	Setup	7.5 IRE

8.4 HD Physical Interfaces

In addition to the analog audio and video interfaces defined in Section 7, the OCHD2 has the output interface requirements defined in this section.

8.4.1 HD Analog Component Video Interface

OCHD2-136: If analog component video outputs are present, the OCHD2 SHALL comply with [CEA-770.3-C] and employ three RCA Phono jack connectors as designated in section 10 of [CEA-770.3-C] and labeled as in Table 8.4-1.

Table 8.4-1 - Connector Color Code Assignment

Signal Assignment (Label)	Color Code
Y	Green
Pb	Blue
Pr	Red

OCHD2-137: If analog component video outputs are present on the OCHD2, a user controlled selection switch (hardware or software) SHALL be provided to allow the user to match the HD output format with the chosen display.

8.4.2 Uncompressed Digital Video Interface

- OCHD2-138: The OCS2 SHALL provide support for an uncompressed digital video interface (output) using either Digital Visual Interface [DVI] or High-Definition Multimedia Interface [HDMI].
- OCHD2-139: The OCT2 SHALL provide support for an uncompressed digital video interface (input) using either Digital Visual Interface [DVI] or High-Definition Multimedia Interface [HDMI].
- OCHD2-140: The OCT2 MAY provide support for an uncompressed digital video interface (output) using either Digital Visual Interface [DVI] or High-Definition Multimedia Interface [HDMI].
- OCHD2-141: If the OCS2 includes a DVI output, it SHALL use a female DVI-D connector, which at a minimum supports the Single Link Transmission Minimized Differential Signaling as defined in [DVI].
- OCHD2-142: If the OCT2 includes a DVI input and/or output, it SHALL use a female DVI-D connector, which at a minimum supports the Single Link Transmission Minimized Differential Signaling as defined in [DVI].
- OCHD2-143: If the OCS2 includes an HDMI output, it SHALL use a female HDMI connector, which at a minimum supports the Single Link Transmission Minimized Differential Signaling as defined in [HDMI].
- OCHD2-144: If the OCT2 includes an HDMI input and/or output, it SHALL use a female HDMI connector, which at a minimum supports the Single Link Transmission Minimized Differential Signaling as defined in [HDMI].
- OCHD2-145: If the OCT2 includes both an input and an output DVI and/or HDMI connector, then each connector SHALL be labeled to indicate whether it is a input or output.
- OCHD2-146: The DVI or HDMI interface on the OCHD2 SHALL employ the HDCP encryption system as defined in [HDCP].
- OCHD2-147: The OCHD2 SHALL enable HDCP encryption at all times when video is transmitted over the DVI or HDMI link.
- OCHD2-148: If HDCP authentication fails, then the OCHD2 SHALL not transmit video over the DVI or HDMI link, excluding any alerts generated by the OCHD2 informing the user of the condition.
- Note: Continued transmission of a blank video field over the DVI or HDMI link for the purpose of muting video in this case is acceptable.

8.4.3 IEEE-1394 Digital Interface

- OCHD2-149a: The IEEE-1394 interface on the OCS2 SHALL include:
- copy protection as defined in OCHD2-10
 - compliance with section 4.1, Initialization and Configuration, and section 4.2, AV/C Discovery Process, of [SCTE 26]
 - Analog / Digital source selection function as defined in sections 4.11 and 6.1 of [CEA-775-B] unless the Host Device supports requirement OCHD2-150b
 - support for [CEA-931-B] PASS THROUGH control commands: tune function, mute function, and restore volume function
 - support for the POWER control commands (power on, power off, and status inquiry) defined in [AV/C]
- OCHD2-149b: The IEEE-1394 interface on the OCT2 SHALL include:
- copy protection as defined in OCHD2-10

- compliance with section 4.1, Initialization and Configuration, and section 4.2, AV/C Discovery Process, of [SCTE 26]
- bit-mapped graphics support (profile 0b) as defined in Section 4.3.5 of [SCTE 26]
- all normative elements of [CEA-775-B]
- Analog / Digital source selection function as defined in Sections 4.11 and 6.1 of [CEA-775-B]

OCHD2-150a: Any OCS2 or OCT2 that supports 1394 source functionality that does not support OCHD2-150c SHALL do a verification of the External Jack Selection function, as defined in [SCTE 26], on any device connected to an isochronous output plug of the OCHD2 device.

If a connected sink device does not support the External Jack Selection function and the OCHD2 determines that the sink device is a TV (i.e., display/monitor) AND the OCHD2 does not support OCHD2-150c AND either the OCHD2 or the connected monitor does not support On-Screen Display (OSD) over 1394, then the OCHD2 SHALL disconnect the isochronous output plug and NOT offer isochronous MPEG2 streams to that sink device and refuse any further connections to that device and update the status of the IEEE-1394 Port Status - A/D Source Selection status as defined in OCHD2-190.

Note 1: This requirement regarding digital output to display devices places no restriction on the functionality of the 1394 port for digital output to non-display devices that may be on the same 1394 bus such as a digital VCR.

Note 2: Support for OSD over 1394 is optional. In the event that the source device does support OSD and the source device determines that the sink device also supports OSD, then the use of the External Jack Selection function is not required.

OCHD2-150b: If an OCS2 or an OCT2 that supports 1394 source functionality includes an MPEG-2 encoder, then it SHALL be designed to encode analog services for delivery over the 1394 interface as a single program transport stream.

OCHD2-150c: If an OCS2 or an OCT2 that supports 1394 source functionality includes an MPEG-2 encoder AND the encoder is designed such that it has the ability to encode graphics, then the device SHALL encode any graphics or user interface messaging for delivery over the IEEE-1394 interface as a single program transport stream, where interface messages includes, at a minimum, Diagnostic Screens, MMI and EAS alerts.

OCHD2-150d: If the OCS2 or an OCT2 that supports 1394 source functionality does not support OCHD2-150c AND either the OCHD2 or the connected monitor does not support On-Screen Display (OSD) over 1394 AND a connected monitor supports External Jack Selection, then the device SHALL utilize the External Jack Selection function to switch a connected TV (i.e., display/monitor) to an analog input port when the device needs to deliver user interface messages to the connected TV, where user interface messages include, at a minimum, Diagnostic Screens, MMI and EAS alerts.

OCHD2-151: The IEEE-1394 interface (source or sink) on the OCHD2 SHALL support the transfer of MPEG-2 single program transport streams (SPTS) via the Isochronous Data Channel (IDC) as specified in sections 4.1 – 4.3, 4.5 – 4.8 and 8.1 – 8.2 of [CEA-775-B].

OCHD2-152: The OCS2 SHALL support simultaneous local decode and pass-through of compressed standard definition MPEG-2 A/V programming.

OCHD2-153: The OCS2 SHALL have the capability to function as the Isochronous Resource Manager (IRM) functionality as defined in section 8 of [IEEE-1394].

OCHD2-154: The OCS2 SHALL have the capability to function as the Cycle Master functionality as defined in section 8 of [IEEE-1394].

8.5 Signal Formats

This subsection lists the requirements on an OCHD2 with respect to the scanning formats and colorimetry of the HD interfaces.

8.5.1 Scanning Formats for the HD Analog Component Video Interface

- OCHD2-155: If analog component video outputs are present on the OCHD2, each of the MPEG formats described in Table 3 of [SCTE 43] SHALL be converted to the selected HD output format on the interface.
- OCHD2-156: If analog component video outputs are present on the OCHD2, it SHALL employ the Y', P_{B'}, P_{R'} component format according to section 8 of [CEA-770.3-C].

8.5.2 Colorimetry for the HD Analog Component Video Interface

- OCHD2-157: If analog component video outputs are present on the OCHD2, the colorimetry SHALL correspond to the requirements in [ITU-R-BT.709-2] and section 5 of [CEA-770.3-C].
- OCHD2-158: If analog component video outputs are present on the OCHD2, the MPEG sequence display extension SHALL be observed when present in the transport stream to determine when color matrix conversion is necessary. For any standard definition MPEG format listed in Table 3 of [SCTE 43] that does not include the sequence display extension, the colorimetry SHALL be converted from SMPTE-170M to [ITU-R-BT.709-2] in the OCS2. User selectable colorimetry conversion MAY be available to override default settings.

8.5.3 Scanning Formats for the DVI Interface

- OCHD2-159: The scanning systems supported on the DVI or HDMI output of the OCS2 SHALL include all of those identified as mandatory for a source device in [CEA-861-B], except for the 640x480p format, which is optional. Other formats listed in [CEA-861-B] as optional MAY also be provided.
- OCHD2-160: The DVI or HDMI input of a OCT2 SHALL support the mandatory parts of [CEA-861-B] for a sink device. Other formats listed in [CEA-861-B] as optional MAY also be supported.
- OCHD2-161: Each of the MPEG formats described in Table 3 of [SCTE 43] SHALL be converted to the user selected or preferred format and aspect ratio of the display device connected to the DVI or HDMI output of the OCS2, as discovered via the Enhanced Extended Display Identification Data (E-EDID) Detailed Timing Descriptions or the CEA Timing Extensions structures communicated from the display to the host via the DVI or HDMI interface, and as constrained by [CEA-861-B].
- OCHD2-162: In the event that the E-EDID data structure or CEA EDID timing extension does not contain a supported timing format or cannot be read, then the DVI or HDMI output SHALL use 640x480p mode, if available. If 640x480p mode is not supported by the OCS2 then 720x480p mode MAY be utilized, if available. If neither mode is available, then the DVI or HDMI output shall be disabled.

8.5.4 Video Transmission Format for the DVI Interface

- OCHD2-163: If the OCHD2 implements a DVI interface, then the OCHD2 SHALL employ the RGB component format according to section 5 of [CEA-861-B].
- OCHD2-163a: If the OCHD2 implements an HDMI interface, then the OCHD2 SHALL employ the RGB component format according to [HDMI].

OCHD2-163b If the OCHD2 implements an HDMI interface and analog component interfaces, then the OCHD2 SHALL also support the YCbCr format according to [HDMI].

8.5.5 Colorimetry for the DVI Interface

OCHD2-164: The DVI or HDMI interface on the OCHD2 SHALL employ the colorimetry requirements according to section 5 of [CEA-861-B]. When present in the transport stream, the MPEG sequence display extension SHALL be observed to determine when color matrix conversion is necessary. User selectable colorimetry conversion MAY be available to override default settings.

8.5.6 Simultaneous Outputs

OCHD2-165: All video and graphics of the OCS2 (including on-screen displays and set-up menus) MAY be output simultaneously to the composite baseband video output, the HD analog component video output (if present), and the DVI or HDMI digital output, subject to copy control restrictions. Note that this may require simultaneous output to interfaces that use different color spaces (RGB for DVI and YPrPb for NTSC and HD analog). The video format of the HD analog component video output MAY match that of the DVI or HDMI output.

OCHD2-166: Incoming Standard Definition video content, received either as an analog or digital signal, SHALL be up-converted to support output to the active High Definition output(s).

OCHD2-167: Selected and authorized video signals on the OCHD2 SHALL be present simultaneously on the composite baseband video output, S-video output and the modulated RF output.

9 AUDIO

- OCHD2-168: The OCHD2 SHALL decode Dolby AC-3 digital audio in accordance with [A/52A] as constrained per [A/53C], with additional data rates up to 448 kbps.
- OCHD2-169: The audio component of selected and authorized digital signals on the OCHD2 SHALL be present simultaneously on the baseband left and right outputs, the modulated RF output, and the digital outputs for all video compression formats listed in Table 3 of [SCTE 43].
- OCHD2-170: If the OCT2 includes audio outputs, the audio component of selected and authorized digital signals on OCS2s SHALL be present simultaneously on the baseband left and right outputs, the modulated RF output, and the digital outputs for all video compression formats listed in Table 3 of [SCTE 43].
- OCHD2-171: For analog services on the OCS2, the selected and authorized audio signals SHALL be present on the baseband left and right outputs and the modulated RF output, and MAY be present on the digital outputs.
- OCHD2-172: If the OCT2 includes audio outputs, the selected and authorized analog signals SHALL be present simultaneously on all such outputs, including when present, the baseband left and right outputs and the modulated RF output, and MAY be present on the digital outputs.
- OCHD2-173: The OCHD2 SHALL use the ISO 639 Language Descriptor, if present, as defined in [ISO 13818-1] and constrained by [SCTE 54], to identify the language associated with audio tracks.
- OCHD2-174: The OCHD2 SHALL be certified by Dolby Laboratories Inc. for Dolby Digital™ decoding.

9.1 Audio Performance Specifications

All audio performance requirements are valid over the operational environmental parameters defined in Table 9.2-1, Table 9.2-2, and Table 9.2-3. These parameters apply to all OCHD2s with audio outputs.

9.2 Music Channel Services

Some music channel services provide both an audio elementary stream and a low frame-rate video elementary stream, typically at one frame every six seconds and a data rate of 50kbps. These low frame-rate video streams have the **low_delay** flag set to "1". The low_delay flag is contained in the sequence_extension(), following the sequence_header() of the video_sequence(). The following is from the MPEG-2 Video standard [ISO 13818-2] concerning the use of the **low_delay** flag.

"low_delay - This flag, when set to "1", indicates that the sequence does not contain any B-pictures, that the frame reordering delay is not present in the VBV description and that the bitstream may contain 'big pictures' ".

'Big pictures' are images that may reside in the VBV buffer for longer than two fields. The VBV buffer will be examined periodically before removing the coded picture to prevent buffer underflow. See section C.7 of [ISO 13818-2] for details

- OCHD2-175: The OCHD2 SHALL use an MPEG-2 decoder that is capable of decoding video streams with the low_delay flag enabled.

Table 9.2-1 - RF Output Audio Performance

	Parameter	Requirement
1.	Modulated Audio Mode	Monophonic or BTSC encoded
2.	Modulation Note: For set-tops with volume control, this spec applies when commanded to "unity" or "nominal" gain	50 kHz peak deviation ± 7 kHz for a digital audio signal of 400Hz at 0dBFS. For analog inputs, the RF output MUST reproduce the original carrier deviation, + or - 10%.
3.	Audio Mute	Minimum 48 dB attenuation

Table 9.2-2 - Baseband Audio Output when a Digital Service is Selected

	Parameter	Requirement
1.	Audio Frequency Response	+/-1 dB from 20 Hz to 20 kHz
2.	Audio Mute	Minimum 60 dB attenuation
3.	Baseband Audio Output Impedance	< 5k ohm for each L&R audio outputs
4.	Audio Output Signal Level (as measured into a 100k ohm load) Note: For set-tops with volume control, this spec applies when commanded to "unity" or "nominal" gain	2.16V p-p to 6.22V p-p with digital levels (0 dBFS), and excluding the effects of dialog normalization and dynamic range compression
5.	Intermodulation Distortion (CCIF method using 4040 Hz and 3960 Hz tones at -14 dBFS input per tone)	0.15% max. referenced to output
6.	Stereo L&R Channel Separation	60 dB min. from 20 Hz to 20 kHz
7.	Stereo L&R Channel Gain Difference	+/- 0.5 dB max. from 20 Hz to 20 kHz, referenced to the left channel response
8.	Stereo L&R Channel Phase Difference	5° max. from 20 Hz to 20 kHz
9.	Total Harmonic Distortion	0.3% max. from 20 Hz to 20 kHz at -10 dB relative to full scale
10.	Audio Signal-to-Noise Ratio Note: For set-tops with volume control, this spec applies when commanded to "unity" or "nominal" gain	80 dB min., 20 Hz to 20 kHz, with 1 kHz test tone at full scale encoder input, dialog normalization and dynamic range compression disabled, using CCIR- 2k weighting
11.	Audio to Video Transmission Time Difference	± 20 msec max

Table 9.2-3 - Baseband Audio Output with Analog Service*

	Parameter	Requirement
1.	Audio Frequency Response	Mono or BTSC Signal: ± 3 dB from 50 Hz to 13 kHz (50 Hz to 10 kHz for Terminal Devices).
2.	Audio Mute	Minimum 60 dB attenuation.
3.	Baseband Audio Output Impedance	< 5k ohm for each L&R audio outputs.
4.	Audio Output Signal Level (as measured into a 100k ohm load) Note: For set-tops with volume control, this spec applies when commanded to "unity" or "nominal" gain	Mono Signal: 1.2V p-p, $\pm 10\%$, with 400 Hz test tone at ± 25 KHz p-p audio subcarrier deviation. BTSC Signal: 1.2V p-p, $\pm 10\%$, with 400 Hz test tone at ± 12.5 kHz p-p audio subcarrier deviation for each L&R channel.
5.	Stereo L&R Channel Separation	BTSC Signal: 20 dB min. at 1 kHz.
6.	Stereo L&R Channel Gain Difference	BTSC Signal: ± 0.5 dB maximum from 50 Hz to 13 kHz, referenced to the left channel response.
7.	Stereo L&R Channel Phase Difference	BTSC Signal: 15° maximum from 50 Hz to 13 kHz.
8.	Total Harmonic Distortion	Mono and BTSC Signals: 3.5% max. from 50 Hz to 13 kHz.
9.	Audio Signal-to-Noise Ratio Note: For set-tops with volume control, this spec applies when commanded to "unity" or "nominal" gain	Mono and BTSC: 48 dB min., 50 Hz to 13 kHz, referenced to a 1000 Hz test tone at ± 25 kHz p-p audio subcarrier deviation, CCIR-2k weighting (45 dB min. from 50 Hz to 10kHz for Terminal Devices).
<p><i>Table Notes:</i></p> <p>* <i>Requirements are based on input test signals provided by NTSC and BTSC signal sources RF modulated to Channel 4.</i></p>		

10 OPENCABLE HOST DEVICE 2 POWERING STATES

Once AC power is applied to the OCHD2 and the CableCARD is installed and initialized, the OCHD2 always has access to network services through the Out-Of-Band channel for network monitoring purposes or for receipt of messages, alarms, or notifications. Thus, when the OCHD2 is "On" (from the subscriber's perspective), it is fully active and providing services that are displayed on the subscriber's television. When it is "Off", it still maintains network connectivity and thus is still consuming power and running the processor, operating system, and navigator shell.

When the OCHD2 is disconnected from AC power or from the cable connection, it is truly off (i.e., not connected to the network). When reconnected, the OCHD2 does not have to re-initialize, but will re-establish network connectivity. The AC power up sequence is slightly longer than the "Off" to "On" sequence, but not as long as initialization.

The operation of the OCHD2 in background mode is not defined in this document.

10.1 CableCARD Background Mode Power Management

OCHD2-176: The minimum power requirements for Background mode SHALL include the following:

- The OCHD2 OOB receiver (including the embedded cable modem) circuitry SHALL be fully powered when a CableCARD is inserted.
- The OCHD2 OOB transmitter (including the embedded cable modem) circuitry SHALL be fully powered when a CableCARD is inserted.
- The CableCARD Device SHALL be fully powered when present.

11 OPENCABLE HOST DEVICE 2 DIAGNOSTICS

OCHD2-177: The OCS2 SHALL be capable of performing self-diagnostics and displaying the results via the LED readout. A minimum set of diagnostics SHALL be available, including, but not limited to:

- OCS2 power status
- OCS2 boot status
- Indication of fatal error (e.g., Checksum error)

OCHD2-178: The OCHD2 SHALL be capable of performing self-diagnostics and displaying via the on-screen display (OSD) the results, that SHALL include, but are not limited to:

- OCHD2 power status
- OCHD2 boot status
- OCHD2 memory allocation
- Software version numbers of code in the OCHD2
- Firmware version
- MAC addresses
- OCHD2 network addresses
- Status of FDC
- Status of FAT
- Status of RDC
- Current channel status
- IEEE-1394 Port status
- DVI / HDMI Port Status
- Status of DOCSIS transport channels

These diagnostics MAY also be displayed on the LED.

OCHD2-179: The OSD display of diagnostics can only be triggered by a pre-determined keystroke sequence, which is defined by the manufacturer.

OCHD2-180: The OCHD2 SHALL support the Generic Diagnostics resource with resource ID 0x01040042 for single-stream CableCARD device operation (S-Mode) or resource ID 0x01040081 for multi-stream CableCARD device operation (M-Mode) including support for all parameters defined in the resource that are present in the OCHD2.

11.1 Diagnostic Parameters

The following subsections describe the self-diagnostics parameters, specified above, that are displayed via the OSD and reported to the CableCARD Device.

11.1.1 Memory Allocation

OCHD2-181: The OCHD2 SHALL be capable of displaying and reporting self-diagnostic memory allocation results that SHALL include, but are not limited to:

- Type of memory being reported (as applicable: ROM, DRAM, SRAM, Flash, HDD, DVD, and NVM)
- Physical size of memory type (in kilobytes, defined to 1024 bytes)

11.1.2 Software Version Number

OCHD2-182: The OCHD2 SHALL be capable of displaying and reporting self-diagnostic software version number results, of all available applications, that SHALL include, but are not limited to:

- Application's name string
- Application's version number
- Software status (active, inactive or downloading)
- If applicable, Application's signature

11.1.3 Firmware Version

OCHD2-183: The OCHD2 SHALL be capable of displaying and reporting self-diagnostic firmware version results that SHALL include, but are not limited to:

- Firmware version number of entire firmware image
- Firmware's release or installation date of entire firmware image.

11.1.4 MAC Addresses

OCHD2-184: The OCHD2 SHALL be capable of displaying and reporting self-diagnostic media access control (MAC) address results that SHALL include, but are not limited to:

- Type of devices being reported (as applicable: Host, CableCARD Device, IEEE-1394, USB, eCM)

NOTE: If multiple devices of the same type exist, then the MAC address for each device type SHALL be reported.

- MAC address of each reported device

11.1.5 Network Addresses

OCHD2-185: The OCHD2 SHALL be capable of displaying and reporting self-diagnostic network address results that SHALL include, but are not limited to:

- Network address of device

NOTE: If multiple network addresses exist, then each network address SHALL be reported.

11.1.6 Status of FDC

OCHD2-186: The OCHD2 SHALL be capable of displaying and reporting forward data channel (FDC) status results that SHALL include, but are not limited to:

- FDC center frequency, in MHz
- Carrier lock status (e.g., LOCKED – NOT LOCKED)

11.1.7 Status of FAT

OCHD2-187: The OCHD2 SHALL be capable of displaying and reporting forward application transport (FAT) channel status results for each tuner that SHALL include, but are not limited to:

- Modulation mode indicator; analog, 64 QAM or 256 QAM, or other.

- If the currently tuned channel is a digital QAM channel, then carrier lock status
- If the currently tuned channel is a digital QAM channel, then PCR lock status; the FAT channel tuner is locked or not locked to the currently tuned service
- If the currently tuned channel is a digital QAM channel, a numerical estimate of the channel's signal to noise ratio in tenths of a dB
- Numerical estimate of the signal level in tenths of a dBmV (peak level for analog, average level for others)

NOTE: When operated at nominal line voltage, at normal room temperature, the reported Level and SNR SHALL be within 6 dBmV and 3 dB of the actual received channel level and SNR, respectively, for the input level range of -15 dBmV to +15 dBmV. Across the input level range from -15 dBmV to +15 dBmV, for any 1 dB change in input level or SNR, the Host SHALL report a power change in the same direction that is not less than 0.5 dB and not more than 2.0 dB.

11.1.8 Status of RDC

OCHD2-188: If the return data channel (RDC) is established, then the OCHD2 SHALL be capable of displaying and reporting reverse data channel (RDC) status results that SHALL include, but are not limited to:

- RDC center frequency, in MHz
- RDC transmitter power level, in dBmV
- RDC data rate (256kbps, 1544kbps or 3088kbps)

11.1.9 Current Channel Status

OCHD2-189: The OCHD2 SHALL be capable of displaying and reporting current channel status results for each other that SHALL include, but are not limited to:

- Channel type; analog or digital
- Authorization status ; OCHD2 is authorized or not authorized for currently tuned service
- Purchasable status ; currently tuned service MAY or MAY NOT be purchased
- Purchased status ; currently tuned service is or is not purchased
- Preview status ; currently tuned service is or is not in preview mode
- If the OCHD2 is utilizing parental control, then parental control status ; currently tuned service is blocked or is not blocked via parental control

11.1.10 IEEE-1394 Port Status

OCHD2-190: The OCHD2 SHALL be capable of displaying and reporting IEEE-1394 Port status results that include, but are not limited to:

- Loop status (loop/no loop exists)
- Root status (OCHD2 is/is not Root node)
- Cycle Master status (OCHD2 is/is not Cycle Master)
- A/D Source Selection status (Monitor does / does not support A/D source selection function)
- Port connection status
 - Port 1 — connected/not connected

Port 2 — connected/not connected

- Total number of nodes (devices) connected to IEEE-1394 bus, with the following information for each node: device subunit type, A/D Source Selection Status, and EUI 64.

11.1.11 DVI / HDMI Port Status

OCHD2-191: The OCHD2 SHALL be capable of displaying and reporting DVI / HDMI Port status results that shall include, but are not limited to:

- Connection status (no connection exists, device connected – not repeater, device connected – repeater)

- Connected device type
- Connected device color space
- HDCP status (not enabled, enabled)
- Host Device HDCP status

non HDCP device
compliant HDCP device
revoked HDCP device

- Video format

The number of horizontal lines associated with the video format on the DVI / HDMI link

The number of vertical lines associated with the video format on the DVI / HDMI link

The scan rate associated with the video format on the DVI / HDMI link

The aspect ratio associated with the video format on the DVI / HDMI link (4:3, 16:9)

Progressive or interlaced video

- Audio format

Audio format type

Audio sample size

Audio sample frequency

11.1.12 Status of DOCSIS transport channels

OCHD2-192: The OCHD2 SHALL be capable of displaying and reporting DOCSIS transport channels status that SHALL include, but are not limited to:

- Downstream center frequency, in MHz
- Downstream received power level, in dBmV
- Downstream carrier lock status (e.g., LOCKED / NOT LOCKED)
- Upstream transmitter center frequency, in MHz
- Upstream transmitter power level, in dBmV
- Upstream symbol rate, in Msps
- Upstream modulation type

11.1.13 Home Network Status

OCHD2-192a The OCHD2 SHALL be capable of displaying, if supported, Home Network status results that include, but are not limited to:

- Maximum number of clients the Host can support
- Host Digital Rights Management (DRM) capability
- Number of connected clients
- Client MAC addresses
- Client IP addresses
- Client DRM capability

12 MECHANICAL

OCHD2-193: The OCHD2 SHALL be capable of dissipating the heat from a CableCARD Device drawing an average of 2.5 watts across the CableCARD interface and be in compliance with of item 15 of Table 12-1.

OCHD2-194: The OCHD2 SHALL have a non-removable nameplate(s) or sticker(s) that includes the following information:

- Vendor ID: 24-bit vendor ID represented as 3 bytes (6 hexadecimal digits). This number SHOULD be assigned by OpenCable to ensure uniqueness.
- Vendor Name: 40 ASCII characters maximum.
- Serial Number or Serial No: 40 ASCII character maximum.

Table 12-1 - Environmental / Mechanical Requirements

(Meet all operational specs. without malfunction, or hard or soft failures, under the following)

	Parameter	Requirement
1.	Required Compliance	All applicable regulatory requirements including, but not limited to: FCC, UL, CSA, and EIA
2.	Input Line Voltage	95 to 125 volts AC
3.	Input Line Frequency	57 to 63 Hz
4.	Nominal Power Consumption	To be specified in watts by manufacturer
5.	Physical Security/Tampering-Resistance	Secure means of evidencing entry into the security portions of the device
6.	RF Susceptibility	RF field of 2 volts/ meter from 40 MHz to 1 GHz
7.	Radiated RF	[47CFR15] compliant
8.	Conducted	[47CFR15], ANSI C63.4-1992 compliant
9.	Lightning Surge Tolerance	UL 1409 voltage surge test 38.1, UL 1449, IEEE C62.41, IEEE 587 compliant. RF Input: 1.5 kV at 1kV/usec, 60 amp peak; AC line input: 6 kV, oscillatory 0.5 μsec rise time 100 kHz.
10.	Line Surge Test	FCC part 68, UL 1459, CSA compliant. Metallic: 3500 v minimum at 5 μsec max. rise time and 600 μsec min. fall time, 20 joules min. Longitudinal: 6500 v at 5 μsec max. rise time, 600 μsec min. decay time, 30 joules min. Note: Only applies to a Host with a phone return modem.
10a.	Line Surge Test	UL 1449 Measured Limiting Voltage test Duty Cycle Test Abnormal Over Voltage Tests.
11.	Power Cross (if Host supports phone modem return)	Metallic: will survive 10 events of 600 v, 10 sec duration and operate. Longitudinal: will survive 10 events of 600 v, 10 sec duration and operate.

	Parameter	Requirement
12.	Electrostatic Discharge	IEC 801-2, withstand 10 discharges at 15 kV to each corner and center of keypad, through a 150 pf capacitor in series with 150 ohm resistor, with device chassis grounded to ESD generator
13.	Brown Out Effects	No corruption of non-volatile memory due to input voltage fluctuations from nominal to zero volts
14.	Operating Ambient Temperature and Humidity	0° to 40° C and 5% to 95% RH non-condensing humidity (See Note 1)
15.	External Surface Temperature (with 125 vac input applied and device on, 25° C ambient temperature, without internal or external fan)	UL 1409 compliant. No external protruding surface point hotter than 50° C for metallic and 60° C for nonmetallic surfaces. No non-accessible surface point hotter than 65° C.
16.	Storage Temperature (non-powered, non-operating)	-20° to +60° C (See Note 1)
17.	Storage Humidity (non-powered, non-operating)	5% to 95% RH non-condensing at 40° C (See Note 1)
18.	Altitude	Operating: -150 to 10,000 ft. AMSL Storage: -150 to 15,000 ft. AMSL (See Note 1)
19.	Thermal Shock	Device meets all operational specs after subjection to: -40° C. for 30 minutes +25° C. for 10 minute +60° C. for 30 minutes (See Note 1)
20.	Humidity Shock	Mil-std-810d method 507.2 Device meets all operational specs after subjection to: raise temp to +60° C and 95% RH over 26 hrs., maintain for 6 hrs., drop to 85% RH while reducing temp to +30° C over 8 hrs., maintain +30° C and 95% RH for 8 hrs. Repeat for 10 cycles. (See Note 1)
21.	Solvent Resistance	No external surface deformation effect of common household solvents, cleaners, waxes (See Note 1)
22.	Shipping Vibration	Fully operational after subjection to swept frequency vibration test applied in each of x, y, z planes with excursion of 0.3 inches at a frequency varied from 10 to 30 Hz back to 10 Hz done six times within 30 minutes. (See Note 1)
23.	Mounting Feet	No marks or stain to varnished wooden surface after 40° C and 95% RH exposure for 10 days under force of 0.75 kg (See Note 1)
24.	Keypad Keys	Fully operational after subjection to 100,000 cycles of each key through its full travel to closure with a 10- to 12-ounce force applied at 60 times per minute. (See Note 1)
25.	Impact Test	Device will not develop any openings creating electrical shock risks after subjection to an impact force of 5 ft. lbs. obtained from a free fall of a 2-inch diameter solid smooth steel sphere weighing 1.18 lbs. (See Note 1)
26.	Static Load on Keypad Keys	No mechanical damages or visible deformation after keypad subjection to a static load of 25 lbs. in the direction of operation of the keys. (See Note 1)

	Parameter	Requirement
27.	Handling Drop Test	Device fully operational and not develop any openings exposing risk of electrical shock after subjection to one drop on the face of the device from a height of 20 inches onto a 2-inch thick smooth surface concrete floor. (See Note 1)
28.	Strain Relief Test	For permanently attached power supply cords, device will withstand steady pull force of 35 lbs. applied to the cord. (See Note 1)
29.	Non-volatile Memory Battery Life	Batteries used to back up non-volatile memory will have a minimum life of: unplugged: 1.5 yrs storage life @ 60° C or less; powered 8 yrs @ 40° C or less.
30.	Microphonic Shock	Device will remain error- or interference-free (i.e., no audio pops, clicks, no data errors, no video artifacts) when subjected to tapping with a reasonable force by placing device on a hard surface without padding or mats and inducing 20 taps from knuckles, flat hands, fists, finger nails, screwdriver handles, plastic hammers to all external surfaces of the device. (See Note 1)
<p><i>Table Notes:</i></p> <p>1. For OCT2s, these parameters are superseded by the manufacturer's specifications.</p>		

13 DSG MODE OPERATION

This section details the OpenCable Host 2.0 operation when using the DSG channel for Out-of-Band communication in Basic or Advanced DSG mode. There is some overlap between this section and both the DSG and CableCARD interface specifications. This section is not intended to contradict or redefine anything listed in the other specifications.

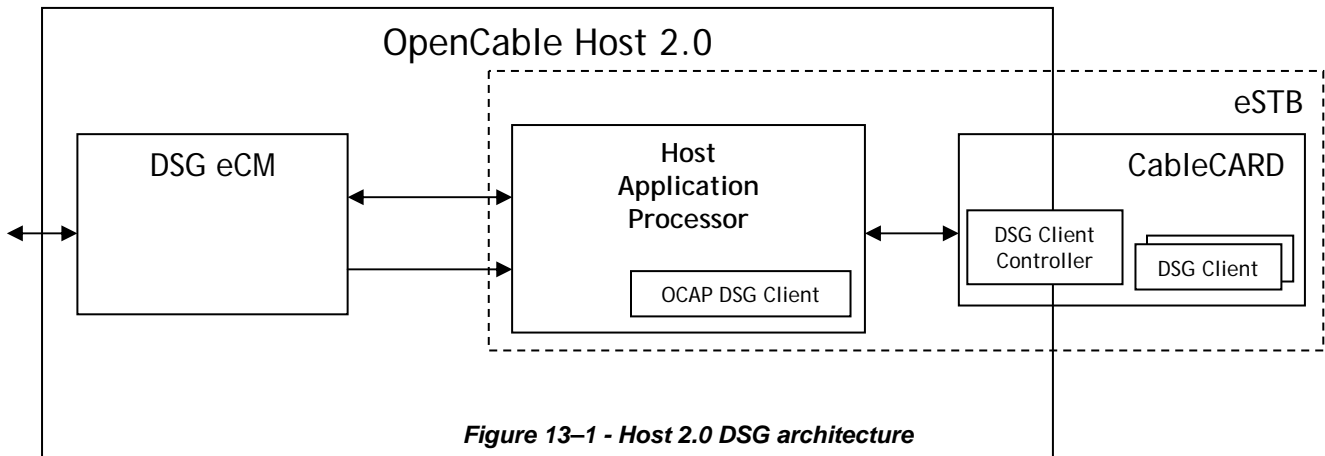

- OCHD2-195: The eCM in the OCHD2 SHALL be implemented according to [RFIv2.0].
- OCHD2-196: The eCM in the OCHD2 SHALL comply with the requirements specified in [eDOCSIS].
- OCHD2-197: The OCHD2 SHALL implement the eSTB eSAFE (embedded Service/Application Functional Entity) as specified in [eDOCSIS].
- OCHD2-198: The OCHD2 SHALL implement the eSTB logical interfaces according to [eDOCSIS].
- OCHD2-199a: The OCHD2 SHALL not implement the DSG Client Controller (DSGCC) function as specified in [DSG].
- OCHD2-199b: The DSG Client Controller (DSGCC) function SHALL reside on the CableCARD.
- OCHD2-200: The eCM in the OCHD2 SHALL not operate in any DSG mode until the operational mode is established by the DSGCC.
- OCHD2-201: The eCM in the OCHD2 SHALL not operate in any DSG mode in the absence of a CableCARD Device, i.e., tunnel packet forwarding disabled.
- OCHD2-202: The eCM in the OCHD2 SHALL remain tuned to a valid DSG channel and continue to forward tunnel packets to the OCHD2 regardless of the state of upstream channel connectivity.
- OCHD2-203: When operating in Advanced Mode the OCHD2 SHALL not determine the validity of or make decisions regarding DCD messages received from the eCM.
- OCHD2-204: Any DSG tunnel with an associated application_id of zero (0) as specified in the set_advanced_mode() message from the CableCARD SHALL be forwarded to the CableCARD device across the Extended Channel Interface using Service_type = DSG.
- OCHD2-205: Any DSG tunnel with an associated application_id that is non-zero as specified in the set_advanced_mode() message from the CableCARD SHALL be forwarded to the OCAP application requesting it.
- OCHD2-206: The OCHD2 SHALL not forward DSG tunnel packets to an OCAP application in the absence of a CableCARD Device.

- OCHD2-207: The OCHD2 SHALL not forward DCD messages to the DSGCC when operating in Basic mode.
- OCHD2-208: The OCHD2 SHALL forward all DSG tunnel packets to the DSGCC when operating in Basic mode.
- OCHD2-209: The OCHD2 SHALL support both Basic and Advanced mode as defined in [DSG].
- OCHD2-210: The OCHD2 SHALL provide a packet buffer with a minimum size of 16 kilobytes for receiving DSG tunnel traffic and DCD fragments.

NOTE: This buffer is for the temporary storage of packets received by the eCM before they are forwarded across the CableCARD interface. Even though DSG tunnels may be rate-shaped individually to a total of 2.048 Mbps, they are not rate-shaped as an aggregate. This buffer size assumes maximum length packets arriving from eight different tunnels back-to-back plus space for DCD message fragments.

13.1 DSG mode selection

1. After initialization, authentication and binding are completed, the OCHD2 operates in OOB mode while the CableCARD downloads a configuration message from the network controller indicating the desired operational mode.
 2. The CableCARD prepares for the transfer of DSG tunnel packets over the Extended Channel by issuing the **new_flow_req()** object to the OCHD2 with *Service_type* = DSG (0x03). The OCHD2 responds with the **new_flow_cnf()** object with *status_field* = 0x00 (**Request granted**) and assigns a unique Flow_ID regardless of whether the OCHD2 is currently operating in the OOB mode or in any DSG mode and the DSG flow has not been established.
 3. If DSG advanced mode is to be established, the CableCARD sends the **set_DSG_mode()** object to the OCHD2 and signals either *Advanced_DSG_mode* or *Advanced_DSG_One-Way_mode* depending on whether the upstream transmitter is to be enabled or not.
 4. If DSG basic mode is to be established, the CableCARD sends the **set_DSG_mode()** object to the OCHD2 and signals either *DSG_mode* or *DSG_One-Way_mode* depending on whether the upstream transmitter is to be enabled or not. This message will include a list of MAC addresses for the eCM to bridge to the CableCARD.
 5. If the OCHD2 does not receive the **set_DSG_mode()** object from the CableCARD in a reasonable amount of time, it may issue the **inquire_DSG_mode()** object to the CableCARD with *inquiry_type* 0x00 (Inquiry) to query the CableCARD as to which operational mode will be used. In either case, eCM initialization will not commence until one of the DSG modes is set by the CableCARD.
- OCHD2-210a: Upon receiving the **new_flow_req()** object with *Service_type* = DSG (0x03) the OCHD2 SHALL grant the DSG flow regardless of whether the OCHD2 is operating in the OOB mode or in any DSG mode and the DSG flow has not been established.
- OCHD2-210b: When the OCHD2 sends the **new_flow_cnf()** object as a response to the **new_flow_req()** object with *Service_type* = DSG (0x03), the *status_field* of the **new_flow_cnf()** object SHALL only contain the value 0x00 or 0x01.
- OCHD2-210c: When operating in the OOB mode, the OCHD2 SHALL discard any SI data (including the SI tables stored in non-volatile memory), and any EAS data that it received from the CableCARD in the OOB mode if it receives a **set_DSG_mode()** to switch to any DSG mode.
- OCHD2-210d: When operating in any DSG mode, the OCHD2 SHALL discard any SI data (including the SI tables stored in non-volatile memory), and any EAS data that it received from the CableCARD in the DSG mode if it receives a **set_DSG_mode()** to switch to OOB mode.

- OCHD2-210e: Upon granting a DSG service flow, the OCHD2 SHALL immediately terminate and close any OOB flow that may exist and terminate the use of the OOB FDC receiver until such time as the DSG flow is closed and an OOB flow opened.
- OCHD2-210f: Upon granting an OOB flow, the OCHD2 SHALL immediately terminate and close any DSG service flow that may exist and terminate the use of the eCM until such time as the OOB flow is closed and a DSG flow opened.
- OCHD2-210g: The OCHD2 SHALL verify the IP headerpacket checksum before sending any DSG packets to the CableCARD.

13.2 DSG Advanced Mode Initialization

1. Once the operational mode has been established, the OCHD2 begins to scan for a valid DSG channel. The DSG eCM downstream scan is identical to the standard DOCSIS scan with the additional requirement that the downstream contain appropriate DSG tunnels.
2. When the eCM finds a DOCSIS channel containing a DCD message, the OCHD2 sends the contents of the DCD message to the CableCARD using the **send_DCD_info()** message. If the CableCARD determines that the downstream channel is valid, it sends a **configure_advanced_DSG()** message to the OCHD2 containing the list of qualifier and application information. The eCM will then remain on the current downstream channel. If the CableCARD determines that the downstream channel is not valid, it sends a **DCD_error()** message to the OCHD2 with the *error_status* field set to *invalid_dsg_channel* and the eCM will continue its scan.
3. If the eCM scans the entire downstream spectrum and does not find a DOCSIS channel containing an appropriate DCD message, the OCHD2 issues the **dsg_message()** object with *message_type* 0x03 (Downstream_Scan_Completed) to inform the CableCARD that it has done a complete scan. At this point, the CableCARD may switch to another out-of-band mode by issuing a **set_DSG_mode()** message.
4. When the eCM has found a valid DSG channel (a DOCSIS downstream containing an appropriate DCD message) it immediately begins forwarding DSG frames to the CableCARD and continues the normal DOCSIS initialization sequence.
5. When DOCSIS registration is complete, the OCHD2 indicates to the CableCARD that 2-Way operation is functional by issuing the **dsg_message()** object with *message_type* 0x01 (2-way OK,UCID).
6. After entering two-way operation, the OCHD2 may request DSG application tunnels from the CableCARD by issuing the **dsg_message()** object with *message_type* 0x00 (application_tunnel_request). The CableCARD may then issue other **configure_advanced_DSG()** messages with information for the requested application tunnels.

13.3 DSG Advanced Mode Operation

1. At any point, the CableCARD may issue a **send_DCD_info()** message with *DCD_data_type* set to 0x01 to change the DSG timers or to set the DSG channel list.
2. The OCHD2 will continue to use the **send_DCD_info()** message to pass the DCD message to the CableCARD.
3. The OCHD2 forwards tunnel packets with an associated *application_id* of zero (0), as specified in the **configure_advanced_DSG()** message, to the CableCARD across the Extended Channel interface.

DSG tunnel packets with a non-zero `application_id` are forwarded to the OCAP application that requested the tunnel.

13.4 DSG Basic Mode Operation

1. Once the operational mode has been established, the OCHD2 begins to scan for a valid DSG channel. The DSG eCM downstream scan is identical to the standard DOCSIS scan with the additional requirement that the downstream contain appropriate DSG tunnels.
2. When the eCM finds a DOCSIS downstream containing the appropriate MAC addresses as specified in the `set_DSG_mode()` message, it remains on that downstream.
3. If the eCM scans the entire downstream spectrum once and does not find a DOCSIS channel containing the appropriate tunnels, the OCHD2 issues the `dsg_message()` object with `message_type` 0x03 (Downstream_Scan_Completed) to inform the CableCARD that it has done a complete scan. At this point, the CableCARD may switch to another out-of-band mode by issuing a `set_DSG_mode()` message.
4. When the eCM has found a valid DSG channel it immediately begins forwarding DSG frames to the CableCARD and continues the normal DOCSIS initialization sequence.

13.5 Application tunnels

One method for OCAP applications to request and receive application tunnels is described below.

1. The OCAP application registers with the OCHD2 by providing its textual name (`source_name`) through the appropriate OCAP API.
2. Assuming that the OCHD2 has already received the SCTE 65 Network Text Table (NTT) delivered to the CableCARD Device over a DSG Broadcast tunnel, the `source_name_subtable` (SNS) is parsed for all mappings between `source_name()` and `application_id`. Using the SNS, the OCHD2 makes an association between the `textual_name` provided by the OCAP application and an `application_id`.
3. The OCHD2 issues the `dsg_message()` object with `message_type` 0x00 (Application_tunnel_request) containing the `application_id(s)` associated with the DSG tunnel(s) required by the OCAP application.
4. The DSGCC parses the DCD message for a match within the DSG Rules and issues the `configure_advanced_DSG()` object with the MAC address corresponding to the desired DSG tunnel along with DSG Classifier Parameters, if applicable, (Source/Dest IP address, TCP/UDP Port address) and the `application_id` requested by the OCHD2.
5. The OCHD2 forwards the addresses to the eCM which begins filtering the desired DSG tunnel packets based on MAC address / DSG Classifier Parameters and passing these packets to the OCHD2.
6. The OCHD2 forwards the DSG tunnel packets to the OCAP application associated with the `application_id` of the tunnel.

13.6 Internet Protocol Flows

The Extended Channel supports delivery of IP packets across the CARD interface for OCHD2s. Both unicast (point-to-point) and multicast (point-to-multipoint) addressing are supported by this protocol. If the OCHD2

is in OOB mode, then the CARD is the link device and services the IP flow via utilization of the OCHD2s RDC and, if able, supplies the OCHD2 with an IP address. On request of a *new_flow_req()* APDU from the OCHD2, the CARD responds to the request to open the flow by obtaining an IP address for use by the OCHD2. The IP address is returned in the *new_flow_cnf()* APDU message.

Informative Note: The CARD is not required to grant a request for service type IP Unicast when requested by the OCHD2.

When in QPSK mode (CARD is the link modem) the CARD transmits all unicast IP packets received to the assigned OCHD2 IP address to the OCHD2 when the OCHD2 has successfully opened a unicast IP flow. The CARD may drop packets when its buffers become full if the OCHD2 is unable to absorb the packets as fast as they are being transmitted.

When in QPSK mode and the CARD has opened an IP flow to the OCHD2, any IP unicast data received from the OCHD2 is transmitted to the network if physically possible.

When in QPSK mode, the CARD may send broadcast IP data to the OCHD2, and the CARD may receive broadcast IP packets from the OCHD2.

If the CARD supports multicast and is in QPSK mode and has granted the OCHD2 a multicast IP flow, all IP data to the multicast IP address is transmitted to the OCHD2. The CARD may drop packets when its buffers become full if the OCHD2 is unable to absorb the packets as fast as they are being transmitted.

OCHD2-211a In DSG mode, the CARD resides at the Network Layer, and the OCHD2 SHALL utilize its eCM to provide the Data Link Layer to the underlying DOCSIS network.

When the CARD wishes to utilize the DOCSIS network to transfer IP packets upstream, it first submits a *new_flow_req()* APDU to the OCHD2 to establish an IP flow to transfer IP packets between the CARD and the OCHD2's eCM interface. The CARD submits its MAC address in its request to the OCHD2 for an IP flow.

If the OCHD2 grants the new IP flow request, then the OCHD2 utilizes DHCP to acquire an IP address for the CARD, and send this information, along with the DOCSIS maximum transmission unit (MTU) (1500 bytes for IP packets) to the CARD in a *new_flow_cnf()* APDU. The OCHD2 now opens an IP flow to the CARD over the Extended Data Channel.

OCHD2-211b When in any DSG mode (OCHD2 is the link modem), the OCHD2 SHALL forward packets received from the eCM interface destined to the CARD via the granted IP Unicast Flow in accordance with the following sections.

The OCHD2 MAY drop packets when its buffers become full if the CARD is unable to absorb the packets as fast as they are being transmitted.

The OCHD2 MAY drop packets received from the Card if the buffering for these packets is exceeded.

OCHD2-211c When in any DSG mode, any IP unicast data received from the CARD SHALL be transmitted to the network if physically possible.

OCHD2-211d When in DSG mode, the OCHD2 MAY send broadcast IP packets to the CARD, and the OCHD2 MAY receive broadcast IP packets from the CARD.

OCHD2-211e When in any DSG mode, and if the OCHD2 supports multicast, the OCHD2 SHALL grant a multicast IP flow when requested by the CARD and transmit all multicast IP packets from the assigned multicast IP address to the CARD.

The OCHD2 MAY drop packets when its buffers become full if the CARD is unable to absorb the packets as fast as they are being transmitted.

The OCHD2 utilizes the Extended Channel's IP flow to forward certain IP packets it receives over the eCM interface to the CARD. The forwarding rules are described in Section 13.6.4.

OCHD2-211f If an established IP type of flow becomes unavailable for any reason, the device that has granted the flow SHALL report that fact to the one that has requested the flow.

The *lost_flow_ind()* APDU is used to report this type of event. One example case where a flow may become unavailable is due to a change in the state of the eCM that may have resulted from a change via SNMP to the eCM's operational state.

When in QPSK mode, the CARD is the network interface and modem. If the OCHD2 requests an IP address, the CARD provides an IP address based on the vendor's proprietary mechanisms. This may be accomplished with DHCP.

When in DSG mode, the OCHD2 is the network interface and modem. The CARD may request an IP flow (and hence an IP address) from the OCHD2 using the *new_flow_req()* APDU by requesting a **service_type** = 0x0 (IP_U flow).

OCHD2-211g If the OCHD2 has not yet completed its network initialization, then it SHALL respond with the *new_flow_cnf()* APDU with **status_field** = 0x03 (Request denied, network unavailable or not responding).

If this occurs, the CARD should periodically attempt to open an IP flow. Once the OCHD2 successfully completes its network initialization and receives its IP address, it should respond to CARD requests for an IP flow by acting as a DHCP proxy for the CARD and attempting to obtain an IP address for the CARD. If an IP address is obtained in this manner, the OCHD2 will respond to the CARD with the *new_flow_cnf()* with **status_field** = 0x00. If an IP address is not obtained for whatever reason, the OCHD2 will respond with **status_field** = 0x05 and not open the flow. The CARD may continue to attempt to open the flow.

When the CARD changes the mode from QPSK to DSG, if there is an IP flow open, the CARD should send a *lost_flow_ind()* APDU with **reason_field** = 0x00 for the flow ID assigned to the OCHD2's IP_U flow. The OCHD2 should respond with the *lost_flow_cnf()* APDU with **indication_field** = 0x00. While it can be assumed that the flow is closed, the OCHD2 should send a *delete_flow_req()* APDU to the CARD to ensure that the flow is deleted. When a OCHD2 receives a *lost_flow_ind()* APDU or sends a *delete_flow_req()* for the IP_U flow, it should discard the previously assigned IP address.

When the CARD changes the mode from DSG to QPSK, if there is an IP flow open, the OCHD2 should send a *lost_flow_ind()* APDU with **reason_field** = 0x00 for the flow ID assigned to the CARD's IP_U flow. The CARD should respond with the *lost_flow_cnf()* APDU with **indication_field** = 0x00. While it can be assumed that the flow is closed, the CARD should send a *delete_flow_req()* APDU to the CARD to ensure that the flow is deleted. When a CARD receives a *lost_flow_ind()* APDU or sends a *delete_flow_req()* for the IP_U flow, it should discard the previously assigned IP address.

13.6.1 eSTB DHCP Requirements

This section describes how the eSTB acquires an IP address through DHCP for its own use.

After the eCM has completed the DOCSIS registration process, it will notify the eSTB by issuing the "2-Way OK, UCID" message as defined in [DSG]. This message is forwarded to the DSG Client controller on the CARD using the *dsg_message()* APDU, which indicates that the eCM has established two-way IP connectivity.

OCHD2-211h At this point, the OCHD2 SHALL invoke DHCP mechanisms according to [RFC 2131] in order to acquire an IP address and any other parameters needed to establish IP connectivity.

- OCHD2-211i The OCHD2 SHALL deny any request from the CARD to open an IP flow until the OCHD2 has acquired an IP address.
- OCHD2-211j The OCHD2 DHCP client behavior during all phases of operation, including initial IP address lease acquisition and lease renewal, SHALL be in accordance with the Client requirements of [RFC 2131] and the DHCP option requirements of [RFC 2132].
- OCHD2-211k The following fields SHALL be present in the DHCPDISCOVER and DHCPREQUEST message from the eSTB and SHALL be set as described below.
- The hardware type (htype) SHALL be set to 1 (Ethernet).
- The hardware length (hlen) SHALL be set to 6.
- The client hardware address (chaddr) SHALL be set to the 48-bit MAC address associated with the OCHD2.
- The Client-identifier option (61) SHALL be included with the hardware type set to 1 and the value set to the same 48-bit MAC address as the chaddr field.
- The "parameter request list" option (55) SHALL be included. The option codes that SHALL be included in the list are:
- Option code 1 (Subnet Mask)
 - Option code 3 (Router Option)
 - Option code 6 (Domain Name Server)
 - Option code 15 (Domain Name)
 - Option code 23 (Default time to live)
 - Option code 51 (IP address lease time)
 - Option code 54 (Server Identifier)
- To enable class identification, each eSTB DHCPDISCOVER and DHCPREQUEST message SHALL include the character string "OpenCable2.0" within DHCP option 60 using characters from the NVT ASCII character set with no terminating NULL.
- DHCP option 43 and its sub-options 2, 3, 4, 5, 6, 7, 8, 9, 10 and 54 SHALL be included. Details of DHCP option 43 and its sub-options for the eSTB are further defined below.
- DHCP option 50, Requested IP Address, SHALL only be included in DHCPREQUEST messages.

The following requirements pertain to the option 43 sub-options in the DHCPDISCOVER and DHCPREQUEST messages from the eSTB.

DHCP option 43 in the eSTB is a compound option. The content of option 43 is composed of one or more sub-options. The option begins with a type octet with the value of number 43, followed by a length octet. The length octet is followed by the number of octets of data equal to the value of the length octet. The value of the length octet does not include the two octets specifying the tag and length. Each sub-option begins with a tag octet containing the sub-option code, followed by a length octet that indicates the total number of octets of data. The value of the length octet does not include itself or the tag octet. The length octet is followed by "length" octets of sub-option data. An example of the option 43 suboptions is given in Table 13.6-1.

- OCHD2-211l The definitions of DHCP option 43 sub-options SHALL conform to requirements imposed by [RFC 2132].

An example implementation of the Vendor Specific Information Option (DHCP option 43) is shown in Table 13.6-1.

- OCHD2-211m The OCHD2 SHALL encode each of the DHCP option 43 sub-options 2, 3, 4, 5, 6, 7, 8, 9, 10, and 54 as a character string consisting of characters from the NVT ASCII character set with no terminating NULL.
- OCHD2-211n The OCHD2 MAY include Option 43 sub-option 1 in DHCPDISCOVER and DHCPREQUEST messages.
- If DHCP option 43 sub-option 1 is included in DHCP client messages, the OCHD2 SHALL encode this sub-option by the number of octets equal to the value of the length octet of this sub-option, with each octet codifying a requested sub-option.
- If the length octet of this sub-option is 0 (because there are no requested sub-options), this sub-option SHOULD be omitted from DHCP option 43.
- OCHD2-211o The OCHD2 SHALL include DHCP option 43 sub-option 2 containing the character string "ESTB" (without the quotation marks).
- OCHD2-211p The OCHD2 SHALL include DHCP option 43 sub-option 3 containing a colon-separated list of all embedded entities in the device, including at a minimum the colon-separated character string "ECM:ESTB:CARD" (without the quotation marks).
- OCHD2-211q The OCHD2 SHALL include DHCP option 43 sub-option 4 containing the device serial number.
- OCHD2-211r The OCHD2 SHALL include DHCP option 43 sub-option 5 containing the Hardware version number, identical to the value as reported in the <Hardware version> field in the MIB object sysDescr.
- OCHD2-211s The OCHD2 SHALL include DHCP option 43 sub-option 6 containing the Software version number, identical to the value as reported in the <Software version> field in the MIB object sysDescr.
- OCHD2-211t The OCHD2 SHALL include DHCP option 43 sub-option 7 containing the Boot ROM version number, identical to the value as reported in the <Boot ROM version> field in the MIB object sysDescr.
- OCHD2-211u The OCHD2 SHALL include DHCP option 43 sub-option 8 containing a 6-octet (6 NVT ASCII characters), hexadecimally-encoded, vendor-specific Organization Unique Identifier (OUI) that uniquely identifies the OCHD2 manufacturer.
- A vendor MAY use the same OUI as in the OCHD2's MAC address, and MAY use a single OUI to identify all its products.
- OCHD2-211v The OCHD2 SHALL include DHCP option 43 sub-option 9 containing the Model number, identical to the value as reported in the <Model number> field in the MIB object sysDescr.
- OCHD2-211w The OCHD2 SHALL include DHCP option 43 sub-option 10 containing the Vendor name, identical to the value as reported in the <Vendor name> field in the MIB object sysDescr.
- OCHD2-211x The OCHD2 SHALL include DHCP option 43 sub-option 54 containing the 40 bit HOST_ID, identical to the value in the Host X.509 certificate.
- OCHD2-211y If the total number of octets in all DHCP option 43 sub-options exceeds 255 octets, the OCHD2 SHALL follow [RFC 3396] to split the option into multiple smaller options.

An example of DHCP option 60 and the DHCP option 43 suboptions is given in Table 13.6-1.

The following requirements pertain to the DHCPACK message.

- OCHD2-212a The OCHD2 SHALL ignore any DHCP options delivered by the DHCP server that the eSTB does not require or cannot interpret.

- OCHD2-212b The OCHD2 SHALL verify the existence of the following DHCP fields within the DHCPPOFFER/DHCPACK message it receives from the DHCP server during initial IP address lease acquisition:
- The IP address to be used by the eSTB (*yiaddr*)
 - The subnet mask to be used by the eSTB (Subnet Mask, Option 1)
 - A list of IP addresses of one or more routers to be used for forwarding eSTB-originated IP traffic (Router, Option 3); the eSTB is not required to use more than one router IP address for forwarding but SHALL use at least one
 - The IP Address Lease Time (Lease Time, Option 51)
 - The Server Identifier of the DHCP server (Server Identifier, Option 54)
- OCHD2-212c If any of the fields mentioned above are absent from the DHCPACK message, the OCHD2 SHALL reject the offered lease and restart its DHCP IP address acquisition process from the INIT state as defined in [RFC 2131].
- OCHD2-212d The OCHD2 SHALL verify the existence of the above-mentioned DHCP fields within the DHCPACK message it receives from the DHCP server during a DHCP Renew or Rebind.
- If the DHCPACK message does not contain the *yiaddr* field, the eSTB SHALL restart its DHCP IP acquisition process from the INIT state as defined in [RFC 2131].
- OCHD2-212e If any required field other than *yiaddr* is missing or is invalid in the DHCPACK message during a DHCP Renew or Rebind, the OCHD2 SHALL ignore any invalid fields, preserve any field values from its initial IP address acquisition or a previous Renew or Rebind, and continue with normal operation. An example of an invalid field would be an option that is syntactically malformed (e.g., with an incorrect option length).

13.6.2 CARD DHCP Requirements

The section describes how the OCHD2 acquires an IP address through DHCP on behalf of the CARD.

After the eSTB has successfully completed the IP address acquisition, it can grant an IP flow across the extended channel when it receives a *new_flow_req()* APDU from the CARD with *service_type* = IP Unicast.

- OCHD2-212f The OCHD2 SHALL use the CARD's MAC address and options field provided in the *new_flow_req()* APDU to obtain an IP address for the CARD using DHCP.
- OCHD2-212g The OCHD2 SHALL act as a DHCP client for the CARD and adhere to all Client requirements specified in [RFC 2131] and [RFC 2132].
- OCHD2-212h The OCHD2 SHALL save the value sent in the *MAC_address* field of the *new_flow_req()* APDU for use in subsequent operations performed on behalf of the CARD.
- OCHD2-212i The OCHD2 SHALL confirm that any received DHCPPOFFER messages are in response to the initial DHCPDISCOVER message by matching the Transaction ID field (*xid*), verifying that the *chaddr* field contains the CARD MAC address and the destination MAC address is the CARD MAC address.
- OCHD2-212j The OCHD2 SHALL confirm that any received DHCPACK messages are in response to the previous DHCPREQUEST message by matching the Transaction ID field (*xid*), verifying that the *chaddr* field contains the CARD MAC address and the destination MAC address is the CARD MAC address.
- OCHD2-212k Once the OCHD2 acquires a unique IP address for the CARD, the OCHD2 SHALL send the *new_flow_cnf()* APDU granting the requested IP Unicast flow and assigning a unique *flow_id*. In this confirmation message the OCHD2 includes the IP address assigned to the CARD.

- The OCHD2 SHOULD set the `option_field_length` field in the `new_flow_cnf()` confirmation message to 0.
- OCHD2-212l The OCHD2 SHALL save the values returned in the `yiaddr` field (IP address assigned to the CARD) and option 51 (IP Address Lease Time) in storage for use in subsequent DHCP operations on behalf of the CARD (INIT-REBOOT, RENEW, REBIND).
- OCHD2-212m All OCHD2 DHCP transactions associated with acquiring the IP address for the CARD SHALL be over the eCM interface and SHALL not propagate to any other interface on the OCHD2.
- OCHD2-212n The OCHD2 SHALL populate the Ethernet frame using the CARD MAC address as the source MAC for all DHCP packets initiated from the OCHD2 on behalf of the CARD.
- OCHD2-212o The OCHD2 SHALL populate the source IP address field with "0.0.0.0" in the IP header during this phase of DHCP operation.
- OCHD2-212p The following fields SHALL be present in the DHCPDISCOVER and DHCPREQUEST message sent by the OCHD2 on behalf of the CARD and SHALL be set as described below:
- The hardware type (`htype`) SHALL be set to 1 (Ethernet).
- The hardware length (`hlen`) SHALL be set to 6.
- The client hardware address (`chaddr`) SHALL be set to the 48-bit MAC address received in the `new_flow_req()` APDU.
- The Client-identifier option (61) SHALL be included with the hardware type set to 1 and the value set to the same 48-bit MAC address as the `chaddr` field.
- The "parameter request list" option (55) SHALL be included. The option codes that SHALL be included in the list are:
- Option code 1 (Subnet Mask)
 - Option code 3 (Router Option)
 - Option code 23 (Default time to live)
 - Option code 51 (IP address lease time)
 - Option code 54 (Server Identifier)
- Options 43 and 60 SHALL be obtained from the `new_flow_req()` APDU. The OCHD2 SHALL NOT reformat these options.
- DHCP option 50, Requested IP Address, SHALL only be included in DHCPREQUEST messages.
- OCHD2-212q The OCHD2 SHALL ignore any DHCP options delivered by the DHCP server that the CARD does not require or cannot interpret.
- OCHD2-212r The OCHD2 SHALL verify the existence of the following DHCP fields within the DHCPACK message it receives from the DHCP server during initial IP address lease acquisition:
- The IP address to be used by the CARD (`yiaddr`)
 - The subnet mask to be used by the OCHD2 on behalf of the CARD (Subnet Mask, Option 1)
 - A list of IP addresses of one or more routers to be used for forwarding CARD-originated IP traffic (Router, Option 3). The OCHD2 is not required to use more than one router IP address for forwarding but SHALL use at least one.
 - The IP Address Lease Time (Lease Time, Option 51)
 - The Server Identifier of the DHCP server (Server Identifier, Option 54)

- OCHD2-212s If any of the fields mentioned above are absent from the DHCPACK message, the OCHD2 SHALL reject the offered lease and restart its DHCP IP address acquisition process from the INIT state as defined in [RFC 2131].
- OCHD2-212t The OCHD2 SHALL verify the existence of the above-mentioned DHCP fields within the DHCPACK message it receives from the DHCP server during a DHCP Renew or Rebind.
- OCHD2-212u If the DHCPACK message does not contain the *yiaddr* field, the eSTB SHALL restart its DHCP IP acquisition process from the INIT state as defined in [RFC 2131].
- OCHD2-212v If any required field other than *yiaddr* is missing or is invalid in the DHCPACK message during a DHCP Renew or Rebind, the OCHD2 SHALL ignore any invalid fields, preserve any field values from its initial IP address acquisition or a previous Renew or Rebind and continue with normal operation. An example of an invalid field would be an option that is syntactically malformed (e.g., with an incorrect option length).

13.6.3 IP Address Lease Renewal

The OCHD2 monitors the operational status of the eCM for changes in state, particularly a re-initialization of the eCM MAC layer or transition to One-Way operation.

- OCHD2-213a If the OCHD2 detects an eCM MAC layer re-initialization, it SHALL confirm both the eSTB IP address lease and the CARD's IP address lease by entering the INIT-REBOOT state for each of these leases as defined in [RFC 2131] after receiving the 2_Way OK indication from the eCM.
- OCHD2-213b All other aspects of IP address lease expiration SHALL be performed by the OCHD2 according to [RFC 2131].

If an IP flow has been established across the CableCARD interface, then the OCHD2 indicates to the CARD that the flow is lost by sending the *lost_flow_ind()* apdu with *reason_field* = 0x02 (Network down or busy). The CARD responds with the *lost_flow_cnf()* APDU acknowledging that the flow has been lost and then requests that the flow be deleted by sending the *delete_flow_req()* APDU. The CARD expects to receive *delete_flow_cnf()* in reply.

- OCHD2-213c The CARD MAY try to re-open the IP flows by sending the *new_flow_req()* apdus.
If the OCHD2 does not terminate the flow when in the INIT-REBOOT state for the Card's IP address lease, then the OCHD2 MAY drop IP packets received from the Card when in this state.
- OCHD2-213d If an IP flow has been established across the CableCARD interface AND the eSTB is forced into the INIT state, then the OCHD2 MAY continue to forward IP packets on behalf of the CARD.
- OCHD2-213e The OCHD2 SHALL monitor the lease expiration time of the CARD's IP address and perform lease renewal on behalf of the CARD as defined in [RFC 2131].
In the event that the renewal process causes the OCHD2 to enter the INIT state on behalf of the Card, or upon CARD IP address lease expiration, the OCHD2 SHALL terminate any open IP flow by sending the *lost_flow_ind()* apdu with *reason_field* = 0x02 (Network down or busy).
The CARD MAY try to re-open the IP flow by sending the *new_flow_req()* apdu.
- OCHD2-213f If the OCHD2 detects that the eCM has transitioned from Two-Way operation to One-Way operation, then the OCHD2 SHALL notify the CARD via the *DSG_message()* APDU with *message_type* set to 0x02 (Entering_one_way_mode).
If an IP flow has been established across the CableCARD interface AND the OCHD2 transitions to One-Way operation, the OCHD2 SHALL terminate the flow by sending the *lost_flow_ind()* apdu with *reason_field* = 0x02 (Network down or busy).

The CARD MAY try to re-open the IP flow by sending the *new_flow_req()* apdu.

When the eCM transitions back to two-way mode, the OCHD2 SHALL enter the INIT-REBOOT state as defined in [RFC 2131] both for the eSTB's IP address and the CARD's IP address.

13.6.4 IP packet Forwarding

The section describes how the OCHD2 performs packet handling for IP packets transmitted by or destined to the CARD.

The OCHD2 forwards IP packets on behalf of the CARD by adding Ethernet framing to packets received from the CARD and removing Ethernet framing from inbound packets before sending to the CARD.

- OCHD2-213g On receipt of an Ethernet frame from the eCM interface targeted to the MAC address of the CARD, the OCHD2 SHALL extract the embedded IP packet and forward the packet to the CARD via the granted IP Unicast Flow.
- OCHD2-213h The OCHD2 SHALL only forward IP packets destined to the CARD that have been received via the eCM interface or via applications resident on the Host.
- OCHD2-213i The OCHD2 SHALL only forward IP packets received from the CARD to the eCM interface or to applications resident on the Host.
- OCHD2-213j The OCHD2 SHALL NOT forward any Ethernet frames or IP packets destined to the CARD that have been received via the eCM interface to any interface other than the CCIF.
- OCHD2-213k On receipt of an IP packet from the CARD via the IP Unicast Flow, the OCHD2 SHALL examine the packet's destination IP address and use the CARD's address mask, obtained by DHCP, to determine if the destination host is on a connected network.
- OCHD2-213l If the OCHD2 has determined that the destination host is on a connected network, the OCHD2 SHALL perform ARP to acquire the destination host MAC address.
- The ARP request payload SHALL contain sender's hardware address equal to the MAC address of the CARD and the sender's protocol address equal to the IP address of the CARD.
- The source MAC address of the Ethernet frame containing the ARP request MAY contain either the Host MAC address or the Card MAC address.
- OCHD2-213m If the destination is not on a connected network, the OCHD2 SHALL perform ARP to acquire the appropriate gateway MAC address.
- The ARP request payload SHALL contain sender's hardware address equal to the MAC address of the CARD and the sender's protocol address equal to the IP address of the CARD.
- The source MAC address of the Ethernet frame containing the ARP request MAY contain either the Host MAC address or the Card MAC address.
- OCHD2-213n After the proper destination MAC address has been determined, the OCHD2 SHALL encapsulate the IP packet within an Ethernet frame using the acquired destination MAC address as the frame's destination MAC address and the CARD's MAC address as the frame's source MAC address.
- The OCHD2 SHALL then forward the Ethernet frame to the eCM interface.
- OCHD2-213o If the OCHD2 receives an ARP request packet with the target protocol address equal to the IP address of the CARD, the OCHD2 SHALL send an ARP reply with sender's hardware address equal to the MAC address of the CARD and the sender's protocol address equal to the IP address of the CARD.

Table 13.6-1 - Embedded OpenCable Host 2.0 Device DHCP Request

DHCP Request Options	Value	Description
CPE Option 60	"OpenCable2.0"	OpenCable Version
CPE Option 43 sub-option 1	"<null>"	The request sub-option vector is a list of sub-options (within option 43) to be returned to client by the server upon reply to the request. None defined.
CPE Option 43 sub-option 2	"ESTB"	Device type of the entity making the DHCP request.
CPE Option 43 sub-option 3	"ECM:ESTB:CARD"	List of embedded devices
CPE Option 43 sub-option 4	"<device serial number>"	Serial Number of eSTB. If Serial Number is not available, then other unique identifier (other than MAC Address), such as HOST_ID, may be utilized
CPE Option 43 sub-option 5	"<hardware version number>"	Hardware version number of eSTB
CPE Option 43 sub-option 6	"<firmware version number>"	Firmware version number of eSTB
CPE Option 43 sub-option 7	"<boot ROM version number>"	Boot ROM version number of eSTB
CPE Option 43 sub-option 8	e.g., "0204DF"	A 6-octet, hexadecimal-encoded, vendor-specific Organization Unique Identifier (OUI) that may match the OUI in the eSTB's MAC address.
CPE Option 43 sub-option 9	e.g., "Xman200"	Vendor model number of eSTB
CPE Option 43 sub-option 10	e.g., "XYZ Broadband"	Vendor name
CPE Option 43 sub-option 54	e.g., "0A859B428"	40 bit HOST_ID as specified in Host X.509 certificate

14 MANAGEMENT REQUIREMENTS

This section details the OpenCable Host 2.0 device management requirements for SNMP in alignment with section 5.2 of [eDOCSIS]. The Management requirements in this section are divided in two parts: SNMP Protocol requirements covered in Section 14.1 and MIB requirements in Section 14.2 and Annex A. The OCHD2 SNMP Management requirements are primarily defined for diagnostic and status report of the OCHD2 core functions and features (Section 3.1.2); therefore, SNMP write access is not commonly specified. In the case SNMP MIB objects with write access being specified, those definitions should not overlap configuration functions that might be present in other interfaces such as [OCAP].

The configuration of the OCHD2 via SNMP is limited to the write access capabilities included in the MIB requirements of this section. It means that the configuration and provisioning of certain read-only MIB objects is expected by mechanism such as Out-Of-Band signaling (Section 5.2.3), or other provisioning mechanisms outside of the scope of this specification. In particular, the configuration of the OCHD2 SNMP agent that provides SNMP access to Management entities via configured SNMPv1v2c community names, SNMP User Names, and Access Control Views is outside the scope of this specification.

14.1 SNMP Protocol requirements

- OCHD2-216: The OCHD2 MAY implement the SNMPv3 protocol framework as defined in STD 62 [RFC3411] through [RFC3415].
- OCHD2-217: The OCHD2 SHALL implement either SNMPv1/v2c Coexistence as defined in [RFC3584], or SNMPv2 Community-based Access as defined in [RFC1902].

14.2 Requirements for OC-STB-HOST-MIB

This section describes the OCHD2 management requirements related to the OCHD2 Core Functional Requirements detailed in Section 3.1.2.

- OCHD2-218: The OCHD2 SHALL implement the MIB objects of OC-STB-HOST-MIB as described in Annex A and Annex B.

14.3 Other Requirements

- OCHD2-219: The OCHD2 SHALL implement the MIB objects of system group in [RFC3418].
- OCHD2-220: The OCHD2 SHALL report the hardware version, Boot ROM image version, vendor name, software version, and model number in the sysDescr object (from [RFC3418]) as described in Table 14.3-1.
- OCHD2-221: The OCHD2 SHALL report each type-value pair in Table 14.3-1 separated with a colon and blank space. Each pair is separated by a ";" followed by a blank space. For instance, a sysDescr of a CM of vendor X, hardware version 5.2, Boot ROM version 1.4, SW version 2.2, and model number X will be as follows:
- any text<<HW_REV: 5.2; VENDOR: X; BOOTR: 1.4; SW_REV 2.2; MODEL: X>>any text

Table 14.3-1 - [RFC3418] sysDescr Format

To report	Format of each field
Hardware Version	HW_REV: <Hardware version>
Vendor Name	VENDOR: <Vendor name>
Boot ROM	BOOTR: <Boot ROM Version>
Software Version	SW_REV: <Software version>
Model Number	MODEL: <Model number>

Annex A MIB Objects Requirements

The following abbreviations and rules apply in this Annex.

- ACC-FN** Accessible for Notify.
- ATRAP** Accessible through SNMP trap.
- D** Deprecated. Deprecated objects are optional. That is, a vendor can choose to implement or not implement the object. If a vendor chooses to implement the object, the object SHALL be implemented correctly according to the MIB definition. If a vendor chooses not to implement the object, an agent SHALL NOT instantiate such object and SHALL respond with the appropriate error/exception condition (e.g., no such object for SNMPv2c).
- M** Mandatory. The object SHALL be implemented correctly according to the MIB definition.
- N-Acc** Not accessible. The object is not accessible and is usually an index in a table.
- NA** Not Applicable (to the device).
- N-Sup** SHALL not support. The device SHALL NOT support the object. That is, an agent SHALL NOT instantiate such object and SHALL respond with the appropriate error/exception condition (e.g., no such object for SNMPv2c).
- O** Optional. A vendor can choose to implement or not implement the object. If a vendor chooses to implement the object, the object SHALL be implemented correctly according to the MIB definition. If a vendor chooses not to implement the object, an agent SHALL NOT instantiate such object and SHALL respond with the appropriate error/exception condition (e.g., no such object for SNMPv2c).
- Ob** Obsolete. It is optional. Though in SNMP convention, obsolete objects should not be implemented, DOCSIS 2.0 OSSI lets vendors choose whether or not to support the obsolete object. That is, a vendor can choose to implement or not implement the object. If a vendor chooses to implement the object, the object SHALL be implemented correctly according to the MIB definition. If a vendor chooses not to implement the object, the SNMP agent SHALL NOT instantiate such object and SHALL respond with the appropriate error/exception condition (e.g., no such object for SNMPv2c).
- RC** Read-Create. The access of the object SHALL be implemented as Read-Create.
- RO** Read-Only. The access of the object SHALL be implemented as Read-Only.
- RW** Read-Write. The access of the object SHALL be implemented as Read-Write.
- RC/RO** Read-Create or Read-Only. The access of the object SHALL be implemented as either Read-Create or Read-Only as described in the MIB definition.
- RW/RO** Read-Write or Read-Only. The access of the object SHALL be implemented as either Read-Write or Read-Only as described in the MIB definition.

OC-STB-HOST-MIB Objects		
ocStbHostHWIdentifiers		
Object	OCHD2	Access
ocStbHostSerialNumber	M	RO
ocStbHostHostID	M	RO
ocStbHostCapabilities	M	RO
ocStbHostAVInterfaceTable		
Object	OCHD2	Access
ocStbHostAVInterfaceIndex	M	N-Acc
ocStbHostAVInterfaceType	M	RO
ocStbHostAVInterfaceDesc	M	RO
ocStbHostAVInterfaceStatus	M	RO
ocStbHostIEEE1394Table		
Object	OCHD2	Access
ocStbHostIEEE1394ActiveNodes	M	RO
ocStbHostIEEE1394DataXMission	M	RO
ocStbHostIEEE1394DTCPStatus	M	RO
ocStbHostIEEE1394LoopStatus	M	RO
ocStbHostIEEE1394RootStatus	M	RO
ocStbHostIEEE1394CycleIsMaster	M	RO
ocStbHostIEEE1394IRMStatus	M	RO
ocStbHostIEEE1394AudioMuteStatus	M	RO
ocStbHostIEEE1394VideoMuteStatus	M	RO
ocStbHostIEEE1394ConnectedDevicesTable		
Object	OCHD2	Access
ocStbHostIEEE1394ConnectedDevicesIndex	M	N-Acc
ocStbHostIEEE1394ConnectedDevicesAVInterfaceIndex	M	RO
ocStbHostIEEE1394ConnectedDevicesSubUnitType	M	RO
ocStbHostIEEE1394ConnectedDevicesEui64	M	RO
ocStbHostIEEE1394ConnectedDevicesADSourceSelectSupport	M	RO
ocStbHostDVIHDMITable		
Object	OCHD2	Access
ocStbHostDVIHDMIOutputType	M	RO
ocStbHostDVIHDMIConnectionStatus	M	RO
ocStbHostDVIHDMIRepeaterStatus	M	RO
ocStbHostDVIHDMIVideoXmissionStatus	M	RO
ocStbHostDVIHDMIHDCPStatus	M	RO
ocStbHostDVIHDMIVideoMuteStatus	M	RO
ocStbHostDVIHDMIOutputFormat	M	RO
ocStbHostDVIHDMIAspectRatio	M	RO
ocStbHostDVIHDMIAudioFormat	M	RO
ocStbHostDVIHDMIAudioSampleRate	M	RO
ocStbHostDVIHDMIAudioChannelCount	M	RO
ocStbHostDVIHDMIAudioMuteStatus	M	RO

OC-STB-HOST-MIB Objects		
ocStbHostComponentVideoTable		
Object	OCHD2	Access
ocStbHostComponentVideoConstrainedStatus	M	RO
ocStbHostComponentOutputFormat	M	RO
ocStbHostComponentAspectRatio	M	RO
ocStbHostComponentVideoMuteStatus	M	RO
ocStbHostRFChannelOutTable		
Object	OCHD2	Access
ocStbHostRFChannelOut	M	RO
ocStbHostRFChannelOutAudioMuteStatus	M	RO
ocStbHostRFChannelOutVideoMuteStatus	M	RO
ocStbHostInBandTunerTable		
Object	OCHD2	Access
ocStbHostInBandTunerModulationMode	M	RO
ocStbHostInBandTunerFrequency	M	RO
ocStbHostInBandTunerInterleaver	M	RO
ocStbHostInBandTunerPower	M	RO
ocStbHostInBandTunerAGCValue	M	RO
ocStbHostInBandTunerSNRValue	M	RO
ocStbHostInBandTunerUnerroreds	M	RO
ocStbHostInBandTunerCorrecteds	M	RO
ocStbHostInBandTunerUncorrectables	M	RO
ocStbHostInBandTunerCarrierLockLost	M	RO
ocStbHostInBandTunerPCRErrors	M	RO
ocStbHostInBandTunerPTSErrors	M	RO
ocStbHostProgramStatusTable		
Object	OCHD2	Access
ocStbHostProgramIndex	M	N-Acc
ocStbHostProgramAVSource	M	RO
ocStbHostProgramAVDestination	M	RO
ocStbHostProgramContentSource	M	RO
ocStbHostProgramContentDestination	M	RO
ocStbHostMpeg2ContentTable		
Object	OCHD2	Access
ocStbHostMpeg2ContentIndex	M	N-Acc
ocStbHostMpeg2ContentProgramNumber	M	RO
ocStbHostMpeg2ContentTransportStreamID	M	RO
ocStbHostMpeg2ContentTotalStreams	M	RO
ocStbHostMpeg2ContentSelectedVideoPID	M	RO
ocStbHostMpeg2ContentSelectedAudioPID	M	RO
ocStbHostMpeg2ContentOtherAudioPIDs	M	RO
ocStbHostMpeg2ContentCCIValue	M	RO

OC-STB-HOST-MIB Objects		
ocStbHostMpeg2ContentAPSValue	M	RO
ocStbHostMpeg2ContentCITStatus	M	RO
ocStbHostMpeg2ContentBroadcastFlagStatus	M	RO
ocStbHostMpeg2ContentEPNStatus	M	RO
ocStbHostAnalogVideoTable		
Object	OCHD2	Access
ocStbHostAnalogVideoProtectionStatus	M	RO
ocStbHostSPDIFTable		
Object	OCHD2	Access
ocStbHostSPDIFAudioFormat	M	RO
ocStbHostSPDIFAudioMuteStatus	M	RO
ocStbHostEasObjects		
Object	OCHD2	Access
ocStbEasMessageStateCode	M	RO
ocStbEasMessageCountyCode	M	RO
ocStbEasMessageCountySubdivisionCode	M	RO
ocStbHostDeviceSoftware		
Object	OCHD2	Access
ocStbHostSoftwareVersion	M	RO
ocStbHostSoftwareOCAPVersion	M	RO
ocStbHostSoftwareDownloadStatus		
Object	OCHD2	Access
ocStbHostSoftwareImageStatus	M	RO
ocStbHostSoftwareCodeDownloadStatus	M	RO
ocStbHostSoftwareCodeObjectName	M	RO
ocStbHostSecuritySubSystem		
Object	OCHD2	Access
ocStbHostSecurityIdentifier	M	RO
ocStbHostCASystemIdentifier	M	RO
ocStbHostCAType	M	RO
ocStbHostPower		
Object	OCHD2	Access
ocStbHostPowerStatus	M	RO
ocStbHostAcOutletStatus	M	RO
ocStbHostUserSettings		
Object	OCHD2	Access
ocStbHostUserSettingsPreferredLanguage	M	RO

OC-STB-HOST-MIB Objects		
ocStbHostAcSwitch		
Object	OCHD2	Access
ocStbHostAcSwitchStatus	M	RO

Annex B OC-STB-HOST-MIB (normative)

OC-STB-HOST-MIB DEFINITIONS ::= BEGIN

IMPORTS

```

TenthdB,
TenthdBmV
    FROM DOCS-IF-MIB                -- RFC 2670
OBJECT-GROUP,
MODULE-COMPLIANCE
    FROM SNMPv2-CONF                -- RFC 2580
Integer32,
Unsigned32,
Counter32,
OBJECT-TYPE,
MODULE-IDENTITY,
OBJECT-IDENTITY
    FROM SNMPv2-SMI                -- RFC 2578
AutonomousType,
DisplayString,
TruthValue,
RowPointer,
TEXTUAL-CONVENTION
    FROM SNMPv2-TC                -- RFC 2579
SnmAdminString
    FROM SNMP-FRAMEWORK-MIB        -- RFC 3411
clabProjOpenCable
    FROM CLAB-DEF-MIB
;

```

ocStbHostMibModule MODULE-IDENTITY

LAST-UPDATED "200604130000Z" -- April 13, 2006

ORGANIZATION "Cable Television Laboratories, Inc."

CONTACT-INFO

```

    "Postal: Cable Television Laboratories, Inc.
    858 Coal Creek Circle
    Louisville, Colorado 80027-9750
    U.S.A.
    Phone: +1 303-661-9100
    Fax: +1 303-661-9199
    E-mail: mibs@cablelabs.com"

```

DESCRIPTION

```

    "This MIB module contains the management objects for the
    management of OpenCable Set-top Host Device."

```

REVISION "200604130000Z" -- April 13, 2006

DESCRIPTION

```

    "Initial version of the OpenCable Set-top Host MIB module.
    This version is published as part of the CableLabs
    OpenCable specification HOST2.0-CFR version I07.
    Copyright 1999-2006 Cable Television Laboratories, Inc.
    All rights reserved."

```

::= { clabProjOpenCable 1 }

--

-- Textual conventions

--

VideoOutputFormat ::= TEXTUAL-CONVENTION

STATUS current

DESCRIPTION

```

    "Defines the output format of the video signal
    horizontal and vertical resolution."

```

```

SYNTAX    INTEGER {
            format480i(1),
            format480p(2),

```

```

        format720p(3),
        format1080i(4)
    }

AudioOutputFormat ::= TEXTUAL-CONVENTION
    STATUS          current
    DESCRIPTION
        "Defines the output format of the audio signal."
    SYNTAX
        INTEGER
        {
            other(1),
            lpcm(2), -- CD-A, DVD-A
            ac3(3), -- Dolby Digital
            eac3(4), -- Dolby Digital Plus
            mpeg1L1L2(5), -- MPEG-1 Layers 1 & 2
            mpeg1L3(6), -- MPEG-1 Layer 3
            mpeg2(7), -- Advanced Audio Coding (AAC-LC)
            mpeg4(8), -- MPEG-4 Advanced Audio Coding
                    -- High Efficiency (AAC PLUS)
            dts(9), -- Digital Theater Sound
            atrac(10) -- Adaptive Transform Acoustic Coding
        }

VideoAspectRatio ::= TEXTUAL-CONVENTION
    STATUS          current
    DESCRIPTION
        "Defines the horizontal and vertical aspect ratio of the
        video signal.
        'fourByThree' means a 4 by 3 aspect ratio.
        'sixteenByNine' means a 16 by 9 aspect ratio.
        'other' indicates a non-specified aspect ratio."
    SYNTAX
        INTEGER {
            other(1),
            fourByThree(2),
            sixteenByNine(3)
        }

--
-- Node definitions
--

ocStbHostNotifications OBJECT IDENTIFIER ::= { ocStbHostMibModule 0 }
ocStbHostMibObjects OBJECT IDENTIFIER ::= { ocStbHostMibModule 1 }

ocStbHostSystem OBJECT IDENTIFIER ::= { ocStbHostMibObjects 1 }
ocStbHostHWIdentifiers OBJECT IDENTIFIER ::= { ocStbHostSystem 1 }
ocStbHostInterfaces OBJECT IDENTIFIER ::= { ocStbHostSystem 2 }

ocStbHostSerialNumber OBJECT-TYPE
    SYNTAX          SnmpAdminString
    MAX-ACCESS      read-only
    STATUS          current
    DESCRIPTION
        "The manufacturer's serial number for this device."
    ::= { ocStbHostHWIdentifiers 1 }

ocStbHostHostID OBJECT-TYPE
    SYNTAX          DisplayString (SIZE(17))
    MAX-ACCESS      read-only
    STATUS          current
    DESCRIPTION
        "Allows the manager to retrieve the 40-bit Host ID
        of the ocStbHost (SNMP apdu TLV #1) in the string
        format indicated below:

        M-MMU-UUU-UUU-UUL

```

Where:

M-MM is the decimal representation of the 10-bit CHICA assigned manufacturer number.

U-UUU-UUU-UU is the decimal representation of the 30-bit manufacturer assigned unit number.

L is a Luhn check digit calculated over the preceding 12 decimal digits.

If the Host ID is unknown, then the string shall be all zeros e.g., '0-000-000-000-000'."

```
 ::= { ocStbHostHWIdentifiers 2 }

ocStbHostCapabilities OBJECT-TYPE
    SYNTAX      INTEGER {
                other(1),
                ochd2(2)
                }
    MAX-ACCESS  read-only
    STATUS      current
    DESCRIPTION
        "The capabilities indication of the STB device.
        'other' means a device which is not described
        by one of the other enumerations in this list
        'ochd2' means the STB device is an OpenCable Host Device
        Version 2 Compliant device."
    ::= { ocStbHostHWIdentifiers 3 }

-- Types appropriate for use when designating devices and interfaces
-- related to OpenCable Hosts. These types, for example, can be used
-- in ocStbHostAVInterfaceType to designate the kind of interface.
-- These types are also appropriate for use in hrDeviceType.
--
--
ocStbHostDevInterfaceTypes OBJECT IDENTIFIER ::= { ocStbHostInterfaces 1 }

ocStbHostOther OBJECT-IDENTITY
    STATUS      current
    DESCRIPTION
        "The type identifier used for an interface not defined
        in this MIB."
    ::= { ocStbHostDevInterfaceTypes 1 }

ocStbHostScte55FdcRx OBJECT-IDENTITY
    STATUS      current
    DESCRIPTION
        "The type identifier used for SCTE-55 FDC Receiver
        (i.e., out-of-band downstream tuner)."
    ::= { ocStbHostDevInterfaceTypes 2 }

ocStbHostScte55RdcTx OBJECT-IDENTITY
    STATUS      current
    DESCRIPTION
        "The type identifier used for SCTE-55 RDC Transmitter
        (i.e., out-of-band upstream transmitter)."
    ::= { ocStbHostDevInterfaceTypes 3 }

ocStbHostScte40FatRx OBJECT-IDENTITY
    STATUS      current
    DESCRIPTION
        "The type identifier used for SCTE-40 FAT Receiver
        (i.e., in-band video tuner)."
    ::= { ocStbHostDevInterfaceTypes 4 }

ocStbHostBbVideoIn OBJECT-IDENTITY
```

```

STATUS      current
DESCRIPTION
    "The type identifier used for baseband video input."
 ::= { ocStbHostDevInterfaceTypes 5 }

ocStbHostBbAudioIn OBJECT-IDENTITY
STATUS      current
DESCRIPTION
    "The type identifier used for baseband audio input."
 ::= { ocStbHostDevInterfaceTypes 6 }

ocStbHostBbVideoOut OBJECT-IDENTITY
STATUS      current
DESCRIPTION
    "The type identifier used for baseband video output."
 ::= { ocStbHostDevInterfaceTypes 7 }

ocStbHostBbAudioOut OBJECT-IDENTITY
STATUS      current
DESCRIPTION
    "The type identifier used for baseband audio output."
 ::= { ocStbHostDevInterfaceTypes 8 }

ocStbHostRfOutCh OBJECT-IDENTITY
STATUS      current
DESCRIPTION
    "The type identifier used for analog RF output."
 ::= { ocStbHostDevInterfaceTypes 9 }

ocStbHostSVideoIn OBJECT-IDENTITY
STATUS      current
DESCRIPTION
    "The type identifier used for SVideo input."
 ::= { ocStbHostDevInterfaceTypes 10 }

ocStbHostSVideoOut OBJECT-IDENTITY
STATUS      current
DESCRIPTION
    "The type identifier used for SVideo output."
 ::= { ocStbHostDevInterfaceTypes 11 }

ocStbHostComponentIn OBJECT-IDENTITY
STATUS      current
DESCRIPTION
    "The type identifier used for Component input."
 ::= { ocStbHostDevInterfaceTypes 12 }

ocStbHostComponentOut OBJECT-IDENTITY
STATUS      current
DESCRIPTION
    "The type identifier used for Component output."
 ::= { ocStbHostDevInterfaceTypes 13 }

ocStbHostDviIn OBJECT-IDENTITY
STATUS      current
DESCRIPTION
    "The type identifier used for DVI input."
 ::= { ocStbHostDevInterfaceTypes 14 }

ocStbHostDviOut OBJECT-IDENTITY
STATUS      current
DESCRIPTION
    "The type identifier used for DVI output."
 ::= { ocStbHostDevInterfaceTypes 15 }

ocStbHostHdmiIn OBJECT-IDENTITY
STATUS      current

```

```

DESCRIPTION
    "The type identifier used for HDMI input."
 ::= { ocStbHostDevInterfaceTypes 16 }

ocStbHostHdmiOut OBJECT-IDENTITY
STATUS      current
DESCRIPTION
    "The type identifier used for HDMI output."
 ::= { ocStbHostDevInterfaceTypes 17 }

ocStbHostRcaSpdifIn OBJECT-IDENTITY
STATUS      current
DESCRIPTION
    "The type identifier used for RCA SPDIF input."
 ::= { ocStbHostDevInterfaceTypes 18 }

ocStbHostRcaSpdifOut OBJECT-IDENTITY
STATUS      current
DESCRIPTION
    "The type identifier used for RCA SPDIF output."
 ::= { ocStbHostDevInterfaceTypes 19 }

ocStbHostToslinkSpdifIn OBJECT-IDENTITY
STATUS      current
DESCRIPTION
    "The type identifier used for Toslink SPDIF input."
 ::= { ocStbHostDevInterfaceTypes 20 }

ocStbHostToslinkSpdifOut OBJECT-IDENTITY
STATUS      current
DESCRIPTION
    "The type identifier used for Toslink SPDIF output."
 ::= { ocStbHostDevInterfaceTypes 21 }

-- A/V Interface Table

ocStbHostAVInterfaceTable OBJECT-TYPE
SYNTAX      SEQUENCE OF OcStbHostAVInterfaceEntry
MAX-ACCESS not-accessible
STATUS      current
DESCRIPTION
    "This table contains a list of A/V (Audio/Video)
    interfaces (video inputs/outputs, tuners, audio
    inputs/outputs) in the ocStbHost."
 ::= { ocStbHostInterfaces 2 }

ocStbHostAVInterfaceEntry OBJECT-TYPE
SYNTAX      OcStbHostAVInterfaceEntry
MAX-ACCESS not-accessible
STATUS      current
DESCRIPTION
    "Each entry describes the type and status of the A/V
    interface on the ocStbHost. The details of A/V interface
    entries may be defined in table extensions as indicated
    in the MIB object ocStbHostAVInterfaceType."
INDEX { ocStbHostAVInterfaceIndex }
 ::= { ocStbHostAVInterfaceTable 1 }

OcStbHostAVInterfaceEntry ::=
SEQUENCE {
    ocStbHostAVInterfaceIndex
        Unsigned32,
    ocStbHostAVInterfaceType
        AutonomousType,
    ocStbHostAVInterfaceDesc
        SnmpAdminString,
    ocStbHostAVInterfaceStatus

```

```

        INTEGER
    }

ocStbHostAVInterfaceIndex OBJECT-TYPE
    SYNTAX      Unsigned32 (1..4294967295)
    MAX-ACCESS  not-accessible
    STATUS      current
    DESCRIPTION
        "Index of the table."
    ::= { ocStbHostAVInterfaceEntry 1 }

ocStbHostAVInterfaceType OBJECT-TYPE
    SYNTAX      AutonomousType
    MAX-ACCESS  read-only
    STATUS      current
    DESCRIPTION
        "An indication of the type of interface.

        If this value is
            ocStbHostHdComponentOut
        then a corresponding entry exists in the
        ocStbHostComponentVideoTable.

        If this value is
            ocStbHostRFOutCh
        then a corresponding entry exists in the
        ocStbHostRFChannelOutTable.

        If this value is
            ocStbHostScte40FatRx
        then a corresponding entry exists in the
        ocStbHostInBandTunerTable.

        If this value is
            hrDeviceOther
        then no further information is available for the device."
    ::= { ocStbHostAVInterfaceEntry 2 }

ocStbHostAVInterfaceDesc OBJECT-TYPE
    SYNTAX      SnmpAdminString
    MAX-ACCESS  read-only
    STATUS      current
    DESCRIPTION
        "Textual description of the A/V Interface "
    ::= { ocStbHostAVInterfaceEntry 3 }

ocStbHostAVInterfaceStatus OBJECT-TYPE
    SYNTAX      INTEGER
                {
                    enabled(1),
                    disabled(2)
                }
    MAX-ACCESS  read-only
    STATUS      current
    DESCRIPTION
        "Status of the interface.
        'enabled' indicates the A/V interface is active and can be
        used for the user.
        'disabled' indicates the A/V interface is currently not
        available for the user due to hardware, software or
        configuration conditions.
        Additional information about the interface status may be
        available in the A/V Type interface Table extensions."
    ::= { ocStbHostAVInterfaceEntry 4 }

--
-- IEEE 1394 Objects

```

--

```
ocStbHostIEEE1394Objects OBJECT IDENTIFIER ::= { ocStbHostInterfaces 3 }
```

```
ocStbHostIEEE1394Table OBJECT-TYPE
    SYNTAX      SEQUENCE OF OcStbHostIEEE1394Entry
    MAX-ACCESS  not-accessible
    STATUS      current
    DESCRIPTION
        "This table contains attributes associated with the
         ocStbHost Interfaces of type IEEE 1394."
    ::= { ocStbHostIEEE1394Objects 1 }
```

```
ocStbHostIEEE1394Entry OBJECT-TYPE
    SYNTAX      OcStbHostIEEE1394Entry
    MAX-ACCESS  not-accessible
    STATUS      current
    DESCRIPTION
        "An entry exists in this table for each
         interface of the type IEEE 1394."
    INDEX { ocStbHostAVInterfaceIndex }
    ::= { ocStbHostIEEE1394Table 1 }
```

```
OcStbHostIEEE1394Entry ::=
    SEQUENCE {
        ocStbHostIEEE1394ActiveNodes      Integer32,
        ocStbHostIEEE1394DataXMission     TruthValue,
        ocStbHostIEEE1394DTCPStatus       TruthValue,
        ocStbHostIEEE1394LoopStatus       TruthValue,
        ocStbHostIEEE1394RootStatus       TruthValue,
        ocStbHostIEEE1394CycleIsMaster    TruthValue,
        ocStbHostIEEE1394IRMStatus        TruthValue,
        ocStbHostIEEE1394AudioMuteStatus   TruthValue,
        ocStbHostIEEE1394VideoMuteStatus  TruthValue
    }
```

```
ocStbHostIEEE1394ActiveNodes OBJECT-TYPE
    SYNTAX      Integer32 (-1 | 0..64)
    UNITS       "nodes"
    MAX-ACCESS  read-only
    STATUS      current
    DESCRIPTION
        "This object allows the manager to retrieve the
         number of nodes connected to the 1394 bus of
         the ocStbHost.
         The value '-1' means unknown number of nodes."
    ::= { ocStbHostIEEE1394Entry 1 }
```

```
ocStbHostIEEE1394DataXMission OBJECT-TYPE
    SYNTAX      TruthValue
    MAX-ACCESS  read-only
    STATUS      current
    DESCRIPTION
        "This object allows the manager to retrieve the
         state of data being transmitted over the 1394
         bus. True indicates that data is being transmitted
         over the 1394 bus."
    ::= { ocStbHostIEEE1394Entry 2 }
```

```
ocStbHostIEEE1394DTCPStatus OBJECT-TYPE
    SYNTAX      TruthValue
    MAX-ACCESS  read-only
    STATUS      current
    DESCRIPTION
        "This object allows the manager to retrieve the
         state of DTCP on the device. True indicates
         that DTCP is enabled and content is being encrypted"
```

```

        of the 1394 link on the ocStbHost."
 ::= { ocStbHostIEEE1394Entry 3 }

ocStbHostIEEE1394LoopStatus OBJECT-TYPE
    SYNTAX      TruthValue
    MAX-ACCESS  read-only
    STATUS      current
    DESCRIPTION
        "This object allows the manager to retrieve the
         state of a Loop present on the 1394 bus. True
         indicates that a Loop is present on the 1394 bus."
 ::= { ocStbHostIEEE1394Entry 4 }

ocStbHostIEEE1394RootStatus OBJECT-TYPE
    SYNTAX      TruthValue
    MAX-ACCESS  read-only
    STATUS      current
    DESCRIPTION
        "This object allows the manager to retrieve the
         state of Root Status on the device. True indicates
         that the set-top is the Root node on the 1394 bus."
 ::= { ocStbHostIEEE1394Entry 5 }

ocStbHostIEEE1394CycleIsMaster OBJECT-TYPE
    SYNTAX      TruthValue
    MAX-ACCESS  read-only
    STATUS      current
    DESCRIPTION
        "This object allows the manager to retrieve the
         state of Cycle Master on the device. True indicates
         that the set-top is Cycle Master on the 1394 bus."
 ::= { ocStbHostIEEE1394Entry 6 }

ocStbHostIEEE1394IRMStatus OBJECT-TYPE
    SYNTAX      TruthValue
    MAX-ACCESS  read-only
    STATUS      current
    DESCRIPTION
        "This object allows the manager to retrieve the
         state of Isochronous Resource Master on the
         device. True indicates that the set-top is IRM
         on the 1394 bus."
 ::= { ocStbHostIEEE1394Entry 7 }

ocStbHostIEEE1394AudioMuteStatus OBJECT-TYPE
    SYNTAX      TruthValue
    MAX-ACCESS  read-only
    STATUS      current
    DESCRIPTION
        "The value 'true' indicates that the audio signal
         is muted for this Interface. 'false' means the audio
         is not muted."
 ::= { ocStbHostIEEE1394Entry 8 }

ocStbHostIEEE1394VideoMuteStatus OBJECT-TYPE
    SYNTAX      TruthValue
    MAX-ACCESS  read-only
    STATUS      current
    DESCRIPTION
        "The value 'true' indicates that the video signal
         is muted for this Interface. 'false' means the video
         signal is not muted."
 ::= { ocStbHostIEEE1394Entry 9 }

ocStbHostIEEE1394ConnectedDevicesTable OBJECT-TYPE
    SYNTAX      SEQUENCE OF OcStbHostIEEE1394ConnectedDevicesEntry
    MAX-ACCESS  not-accessible

```

```

STATUS      current
DESCRIPTION
    "This table contains A/D Source Selection attributes
    associated to devices connected to the ocStbHost
    Interfaces of type IEEE 1394."
 ::= { ocStbHostIEEE1394Objects 2 }

ocStbHostIEEE1394ConnectedDevicesEntry OBJECT-TYPE
SYNTAX      OcStbHostIEEE1394ConnectedDevicesEntry
MAX-ACCESS  not-accessible
STATUS      current
DESCRIPTION
    "An entry exist in this table for each
    device connected to all Interfaces of
    the type IEEE 1394."
INDEX { ocStbHostIEEE1394ConnectedDevicesIndex }
 ::= { ocStbHostIEEE1394ConnectedDevicesTable 1 }

OcStbHostIEEE1394ConnectedDevicesEntry ::=
SEQUENCE {
    ocStbHostIEEE1394ConnectedDevicesIndex
        Unsigned32,
    ocStbHostIEEE1394ConnectedDevicesAVInterfaceIndex
        Unsigned32,
    ocStbHostIEEE1394ConnectedDevicesSubUnitType
        INTEGER,
    ocStbHostIEEE1394ConnectedDevicesEui64
        OCTET STRING,
    ocStbHostIEEE1394ConnectedDevicesADSourceSelectSupport
        TruthValue
}

ocStbHostIEEE1394ConnectedDevicesIndex OBJECT-TYPE
SYNTAX      Unsigned32(1..4294967295)
MAX-ACCESS  not-accessible
STATUS      current
DESCRIPTION
    "The unique identifier of the connected device entry."
 ::= { ocStbHostIEEE1394ConnectedDevicesEntry 1 }

ocStbHostIEEE1394ConnectedDevicesAVInterfaceIndex OBJECT-TYPE
SYNTAX      Unsigned32(1..4294967295)
MAX-ACCESS  read-only
STATUS      current
DESCRIPTION
    "This object allows the manager to retrieve the
    index value associated with the IEEE1394
    instance of ocStbHostAVInterfaceIndex
    to which the device is physically connected."
 ::= { ocStbHostIEEE1394ConnectedDevicesEntry 2 }

ocStbHostIEEE1394ConnectedDevicesSubUnitType OBJECT-TYPE
SYNTAX      INTEGER {
        monitor(0),
        audio(1),
        printer(2),
        disc(3),
        tape(4),
        tuner(5),
        ca(6),
        camera(7),
        reserved(8),
        panel(9),
        other(10)
        }
MAX-ACCESS  read-only
STATUS      current

```

```

DESCRIPTION
    "This object allows the manager to retrieve the
    Subunit Type associated with the device connected
    to the ocStbHost's IEEE1394 interface."
 ::= { ocStbHostIEEE1394ConnectedDevicesEntry 3 }

ocStbHostIEEE1394ConnectedDevicesEui64 OBJECT-TYPE
SYNTAX      OCTET STRING (SIZE (8))
MAX-ACCESS  read-only
STATUS      current
DESCRIPTION
    "This object allows the manager to retrieve the
    64-bit Extended Unique Identifier (EUI-64)
    associated with the device connected
    to the ocStbHost's IEEE1394 interface."
 ::= { ocStbHostIEEE1394ConnectedDevicesEntry 4 }

ocStbHostIEEE1394ConnectedDevicesADSourceSelectSupport OBJECT-TYPE
SYNTAX      TruthValue
MAX-ACCESS  read-only
STATUS      current
DESCRIPTION
    "This object allows the manager to retrieve the
    status of Analog/Digital Source Selection support
    associated with the device connected to the
    ocStbHost's IEEE1394 interface.
    'true' indicates that the device supports A/D
    source selection."
 ::= { ocStbHostIEEE1394ConnectedDevicesEntry 5 }

ocStbHostDigitalVideoOutput OBJECT IDENTIFIER ::= { ocStbHostInterfaces 4 }

ocStbHostDVIHDMItable OBJECT-TYPE
SYNTAX      SEQUENCE OF OcStbHostDVIHDMIEntry
MAX-ACCESS  not-accessible
STATUS      current
DESCRIPTION
    "This table allows the manager to retrieve information
    about the DVI/HDMI port of the ocStbHost."
 ::= { ocStbHostDigitalVideoOutput 1 }

ocStbHostDVIHDMIEntry OBJECT-TYPE
SYNTAX      OcStbHostDVIHDMIEntry
MAX-ACCESS  not-accessible
STATUS      current
DESCRIPTION
    "An entry exists for each A/V interface of type HDMI or DVI
    of the ocStbHost."
INDEX { ocStbHostAVInterfaceIndex }
 ::= { ocStbHostDVIHDMItable 1 }

OcStbHostDVIHDMIEntry ::=
SEQUENCE {
    ocStbHostDVIHDMIOutputType
        INTEGER,
    ocStbHostDVIHDMIConnectionStatus
        TruthValue,
    ocStbHostDVIHDMIRepeaterStatus
        TruthValue,
    ocStbHostDVIHDMIVideoXmissionStatus
        TruthValue,
    ocStbHostDVIHDMIHDCPStatus
        TruthValue,
    ocStbHostDVIHDMIVideoMuteStatus
        TruthValue,
    ocStbHostDVIHDMIOutputFormat
        VideoOutputFormat,

```

```

        ocStbHostDVIHDMIAspectRatio
            VideoAspectRatio,
        ocStbHostDVIHDMIAudioFormat
            AudioOutputFormat,
        ocStbHostDVIHDMIAudioSampleRate
            INTEGER,
        ocStbHostDVIHDMAudioChannelCount
            Unsigned32,
        ocStbHostDVIHDMIAudioMuteStatus
            TruthValue
    }

-- Modify:

ocStbHostDVIHDMIOutputType OBJECT-TYPE
    SYNTAX      INTEGER
                {
                    dvi(1),
                    hdmi(2)
                }
    MAX-ACCESS  read-only
    STATUS      current
    DESCRIPTION
        "This object defines the operational mode of the
        interface, where valid modes are dependant on
        the physical interface defined.

        If ocStbHostAVInterfaceIndex is DVI, then
        this value is always set to 1 (DVI).

        If ocStbHostAVInterfaceIndex is HDMI, then
        this value is either 1 (DVI) or 2 (HDMI)."
```

```
 ::= { ocStbHostDVIHDMIEntry 2 }
```

```

ocStbHostDVIHDMIConnectionStatus OBJECT-TYPE
    SYNTAX      TruthValue
    MAX-ACCESS  read-only
    STATUS      current
    DESCRIPTION
        "This object allows the manager to retrieve the
        state of the DVI/HDMI port on the device.
        'true' indicates that a device is connected to
        the ocStbHost."
    ::= { ocStbHostDVIHDMIEntry 3 }
```

```

ocStbHostDVIHDMIRepeaterStatus OBJECT-TYPE
    SYNTAX      TruthValue
    MAX-ACCESS  read-only
    STATUS      current
    DESCRIPTION
        "This object allows the manager to retrieve the
        presence of a repeater connected to the ocStbHost.
        'true' indicates that a repeater is connected
        to the ocStbHost."
    ::= { ocStbHostDVIHDMIEntry 4 }
```

```

ocStbHostDVIHDMIVideoXmissionStatus OBJECT-TYPE
    SYNTAX      TruthValue
    MAX-ACCESS  read-only
    STATUS      current
    DESCRIPTION
        "This object allows the manager to retrieve the
        state of video transmission over the DVI/HDMI port
        of the ocStbHost. 'true' indicates that video is being
        transmitted over the DVI/HDMI link to a connected
        device."
    ::= { ocStbHostDVIHDMIEntry 5 }
```

```

ocStbHostDVIHDMIHDCPStatus OBJECT-TYPE
    SYNTAX      TruthValue
    MAX-ACCESS  read-only
    STATUS      current
    DESCRIPTION
        "This object allows the manager to retrieve the
         state of the digital copy protection protocol in the
         interface.
         'true' indicates that HDCP encryption is enabled."
    ::= { ocStbHostDVIHDMIEntry 6 }

ocStbHostDVIHDMIVideoMuteStatus OBJECT-TYPE
    SYNTAX      TruthValue
    MAX-ACCESS  read-only
    STATUS      current
    DESCRIPTION
        "The value 'true' indicates that the video signal
         is being muted over the DVI/HDMI link. 'false' means
         the video signal is not muted."
    ::= { ocStbHostDVIHDMIEntry 7 }

ocStbHostDVIHDMIOutputFormat OBJECT-TYPE
    SYNTAX      VideoOutputFormat
    MAX-ACCESS  read-only
    STATUS      current
    DESCRIPTION
        "This object allows the manager to retrieve the
         video timing format currently being transmitted
         over the DVI/HDMI link."
    ::= { ocStbHostDVIHDMIEntry 8 }

ocStbHostDVIHDMIAspectRatio OBJECT-TYPE
    SYNTAX      VideoAspectRatio
    MAX-ACCESS  read-only
    STATUS      current
    DESCRIPTION
        "This object allows the manager to retrieve the
         aspect ratio applicable to the video timing
         format currently being transmitted over the
         DVI/HDMI link. e.g., 4/3 or 16/9."
    ::= { ocStbHostDVIHDMIEntry 9 }

ocStbHostDVIHDMIAudioFormat OBJECT-TYPE
    SYNTAX      AudioOutputFormat
    MAX-ACCESS  read-only
    STATUS      current
    DESCRIPTION
        "This object allows the manager to retrieve the
         audio format being transmitted over the
         HDMI link. If this entry corresponds to a DVI interface,
         this object is not instantiated."
    ::= { ocStbHostDVIHDMIEntry 11 }

ocStbHostDVIHDMIAudioSampleRate OBJECT-TYPE
    SYNTAX      INTEGER
                {
                    other(1),
                    samplerate32kHz(2),
                    samplerate44kHz(3),
                    samplerate48kHz(4),
                    samplerate88kHz(5),
                    samplerate96kHz(6),
                    samplerate176kHz(7),
                    samplerate192kHz(8)
                }
    MAX-ACCESS  read-only

```

```

STATUS      current
DESCRIPTION
    "This object allows the manager to retrieve the
    audio sample rate being transmitted over the
    HDMI link. If this entry corresponds to a DVI interface,
    this object is not instantiated."
 ::= { ocStbHostDVIHDMIEntry 12 }

ocStbHostDVIHDMIAudioChannelCount OBJECT-TYPE
SYNTAX      Unsigned32 (0..10)
UNITS       "channels"
MAX-ACCESS  read-only
STATUS      current
DESCRIPTION
    "This object allows the manager to retrieve the
    audio channel count being transmitted over the
    HDMI link. If this entry corresponds to a DVI interface,
    this object is not instantiated."
 ::= { ocStbHostDVIHDMIEntry 13 }

ocStbHostDVIHDMIAudioMuteStatus OBJECT-TYPE
SYNTAX      TruthValue
MAX-ACCESS  read-only
STATUS      current
DESCRIPTION
    "The value 'true' indicates that the audio signal is muted
    over the DVI/HDMI link. 'false' means the audio is not
    muted. This object is not instantiated for entries of
    ocStbHostDVIHDMIOutputType 'dvi'."
 ::= { ocStbHostDVIHDMIEntry 14 }

--
-- Analog Video Table Information
--

ocStbHostAnalogOutput OBJECT IDENTIFIER ::= { ocStbHostInterfaces 5 }

ocStbHostComponentVideoTable OBJECT-TYPE
SYNTAX      SEQUENCE OF OcStbHostComponentVideoEntry
MAX-ACCESS  not-accessible
STATUS      current
DESCRIPTION
    "This table allows the manager to retrieve information
    about a Component Video interface of the ocStbHost."
 ::= { ocStbHostAnalogOutput 1 }

ocStbHostComponentVideoEntry OBJECT-TYPE
SYNTAX      OcStbHostComponentVideoEntry
MAX-ACCESS  not-accessible
STATUS      current
DESCRIPTION
    "An entry for each interface of type
    'ocStbHostComponentOut'."
INDEX { ocStbHostAVInterfaceIndex }
 ::= { ocStbHostComponentVideoTable 1 }

OcStbHostComponentVideoEntry ::=
SEQUENCE {
    ocStbHostComponentVideoConstrainedStatus TruthValue,
    ocStbHostComponentOutputFormat          VideoOutputFormat,
    ocStbHostComponentAspectRatio           VideoAspectRatio,
    ocStbHostComponentVideoMuteStatus      TruthValue
}

ocStbHostComponentVideoConstrainedStatus OBJECT-TYPE
SYNTAX      TruthValue
MAX-ACCESS  read-only

```

```

STATUS      current
DESCRIPTION
    "This object allows the manager to retrieve the
    state of Constrained Video Image on the port.
    True indicates that video is being constrained
    over the component video output port."
 ::= { ocStbHostComponentVideoEntry 1 }

ocStbHostComponentOutputFormat OBJECT-TYPE
SYNTAX      VideoOutputFormat
MAX-ACCESS  read-only
STATUS      current
DESCRIPTION
    "This object allows the manager to retrieve the
    video format currently being transmitted over
    the Component Video output port."
 ::= { ocStbHostComponentVideoEntry 2 }

ocStbHostComponentAspectRatio OBJECT-TYPE
SYNTAX      VideoAspectRatio
MAX-ACCESS  read-only
STATUS      current
DESCRIPTION
    "This object allows the manager to retrieve the
    video aspect ratio currently being transmitted over
    the Component Video output port."
 ::= { ocStbHostComponentVideoEntry 3 }

ocStbHostComponentVideoMuteStatus OBJECT-TYPE
SYNTAX      TruthValue
MAX-ACCESS  read-only
STATUS      current
DESCRIPTION
    "The value 'true' indicates that the video signal is
    muted for this Interface. 'false' means the video
    signal is not muted."
 ::= { ocStbHostComponentVideoEntry 4 }

--
-- NTSC RF Output
--

ocStbHostRFChannelOutTable OBJECT-TYPE
SYNTAX      SEQUENCE OF OcStbHostRFChannelOutEntry
MAX-ACCESS  not-accessible
STATUS      current
DESCRIPTION
    "This table allows the manager to retrieve information
    about an RF channel output interface of the ocStbHost."
 ::= { ocStbHostAnalogOutput 2 }

ocStbHostRFChannelOutEntry OBJECT-TYPE
SYNTAX      OcStbHostRFChannelOutEntry
MAX-ACCESS  not-accessible
STATUS      current
DESCRIPTION
    "An entry for each interface of type 'ocStbHostRFOutCh'."
INDEX { ocStbHostAVInterfaceIndex }
 ::= { ocStbHostRFChannelOutTable 1 }

OcStbHostRFChannelOutEntry ::=
SEQUENCE {
    ocStbHostRFChannelOut                Unsigned32,
    ocStbHostRFChannelOutAudioMuteStatus TruthValue,
    ocStbHostRFChannelOutVideoMuteStatus TruthValue
}

```

```

ocStbHostRFChannelOut OBJECT-TYPE
    SYNTAX      Unsigned32 (3..99)
    MAX-ACCESS  read-only
    STATUS      current
    DESCRIPTION
        "Indicates the RF channel out value. Typical values are
         3 or 4 for Channels 3 and 4, respectively."
    ::= { ocStbHostRFChannelOutEntry 2 }

ocStbHostRFChannelOutAudioMuteStatus OBJECT-TYPE
    SYNTAX      TruthValue
    MAX-ACCESS  read-only
    STATUS      current
    DESCRIPTION
        "The value 'true' indicates that the audio signal is
         muted for this Interface. 'false' means the audio
         is not muted."
    ::= { ocStbHostRFChannelOutEntry 3 }

ocStbHostRFChannelOutVideoMuteStatus OBJECT-TYPE
    SYNTAX      TruthValue
    MAX-ACCESS  read-only
    STATUS      current
    DESCRIPTION
        "The value 'true' indicates that the video signal is
         muted for this Interface. 'false' means the video
         signal is not muted."
    ::= { ocStbHostRFChannelOutEntry 4 }

--
-- Sony Philips Digital Audio Interface
--

ocStbHostSPDIfTable OBJECT-TYPE
    SYNTAX      SEQUENCE OF OcStbHostSPDIfEntry
    MAX-ACCESS  not-accessible
    STATUS      current
    DESCRIPTION
        "This table allows the manager to retrieve information
         about the SONY, Philips Digital (SPD) Interface of the
         ocStbHost."
    ::= { ocStbHostInterfaces 6 }

ocStbHostSPDIfEntry OBJECT-TYPE
    SYNTAX      OcStbHostSPDIfEntry
    MAX-ACCESS  not-accessible
    STATUS      current
    DESCRIPTION
        "An entry exists for each Audio interface of type SPD."
    INDEX { ocStbHostAVInterfaceIndex }
    ::= { ocStbHostSPDIfTable 1 }

OcStbHostSPDIfEntry ::= SEQUENCE {
    ocStbHostSPDIfAudioFormat      AudioOutputFormat,
    ocStbHostSPDIfAudioMuteStatus  TruthValue
}

ocStbHostSPDIfAudioFormat OBJECT-TYPE
    SYNTAX      AudioOutputFormat
    MAX-ACCESS  read-only
    STATUS      current
    DESCRIPTION
        "The format of the Audio stream transmitted over this
         interface."
    ::= { ocStbHostSPDIfEntry 1 }

ocStbHostSPDIfAudioMuteStatus OBJECT-TYPE

```

```

SYNTAX      TruthValue
MAX-ACCESS  read-only
STATUS      current
DESCRIPTION
    "The value 'true' indicates that the audio signal is muted
    over the SPDIF link. 'false' means the audio is not muted."
 ::= { ocStbHostSPDIFEntry 2 }

```

```
ocStbHostServiceProgramInfo OBJECT IDENTIFIER ::= { ocStbHostInterfaces 7 }
```

```

ocStbHostInBandTunerTable OBJECT-TYPE
SYNTAX      SEQUENCE OF OcStbHostInBandTunerEntry
MAX-ACCESS  not-accessible
STATUS      current
DESCRIPTION
    "This Object Table allows the manager to retrieve
    information regarding the In-Band tuner(s) in
    the ocStbHost."
 ::= { ocStbHostServiceProgramInfo 1 }

```

```

ocStbHostInBandTunerEntry OBJECT-TYPE
SYNTAX      OcStbHostInBandTunerEntry
MAX-ACCESS  not-accessible
STATUS      current
DESCRIPTION
    "This entry contains information regarding
    a tuner of type ocStbHostScte40FatRx in the ocStbHost."
INDEX { ocStbHostAVInterfaceIndex }
 ::= { ocStbHostInBandTunerTable 1 }

```

```

OcStbHostInBandTunerEntry ::=
SEQUENCE {
    ocStbHostInBandTunerModulationMode
        INTEGER,
    ocStbHostInBandTunerFrequency
        Unsigned32,
    ocStbHostInBandTunerInterleaver
        INTEGER,
    ocStbHostInBandTunerPower
        TenthdBmV,
    ocStbHostInBandTunerAGCValue
        Unsigned32,
    ocStbHostInBandTunerSNRValue
        TenthdB,
    ocStbHostInBandTunerUnerroreds
        Counter32,
    ocStbHostInBandTunerCorrecteds
        Counter32,
    ocStbHostInBandTunerUncorrectables
        Counter32,
    ocStbHostInBandTunerCarrierLockLost
        Counter32,
    ocStbHostInBandTunerPCRErrors
        Counter32,
    ocStbHostInBandTunerPTSErrors
        Counter32
}

```

```

ocStbHostInBandTunerModulationMode OBJECT-TYPE
SYNTAX      INTEGER
            {
                other(1),
                analog(2),
                qam64(3),
                qam256(4)
            }
MAX-ACCESS  read-only

```

```

STATUS      current
DESCRIPTION
    "The In-band tuner modulation mode.

    Modulation modes are as follows:
    other    - IB is configured in a manner not described
              by any other listed mode.
    Analog   - IB is configured for analog service.
    QAM-64   - IB is configured for a digital service that
              is 64-QAM.
    QAM-256  - IB is configured for a digital service that
              is 256-QAM."
 ::= { ocStbHostInBandTunerEntry 1 }

ocStbHostInBandTunerFrequency OBJECT-TYPE
SYNTAX      Unsigned32
UNITS       "hertz"
MAX-ACCESS  read-only
STATUS      current
DESCRIPTION
    "This object allows the manager to retrieve the center
    frequency of the currently tuned channel in Hz."
 ::= { ocStbHostInBandTunerEntry 2 }

ocStbHostInBandTunerInterleaver OBJECT-TYPE
SYNTAX      INTEGER {
    unknown(1),
    other(2),
    taps64Increment2(3),
    taps128Increment1(4),
    taps128increment2(5),
    taps128increment3(6),
    taps128increment4(7),
    taps128increment5(8),
    taps128increment6(9),
    taps128increment7(10),
    taps128increment8(11)
    }
MAX-ACCESS  read-only
STATUS      current
DESCRIPTION
    "The in-band interface interleaver value.
    'taps64Increment2' set to '1' indicates the support of
    j = 64, i = 2 interleave.
    'taps128Increment1' set to '1' indicates the support of
    j = 128, i = 1 interleave.
    'taps12increment17' set to '1' indicates the support of
    j = 12, i = 17 interleave.
    'taps128increment2' set to '1' indicates the support of
    j = 128, i = 2 interleave.
    'taps128increment3' set to '1' indicates the support of
    j = 128, i = 3 interleave.
    'taps128increment4' set to '1' indicates the support of
    j = 128, i = 4 interleave.
    'taps128increment5' set to '1' indicates the support of
    j = 128, i = 5 interleave.
    'taps128increment6' set to '1' indicates the support of
    j = 128, i = 6 interleave.
    'taps128increment7' set to '1' indicates the support of
    j = 128, i = 7 interleave.
    'taps128increment8' set to '1' indicates the support of
    j = 128, i = 8 interleave."
 ::= { ocStbHostInBandTunerEntry 3 }

ocStbHostInBandTunerPower OBJECT-TYPE
SYNTAX      TenthdBmV
UNITS       "dBmV"

```

```

MAX-ACCESS read-write
STATUS current
DESCRIPTION
    "The received power level of this in-band interface."
 ::= { ocStbHostInBandTunerEntry 4 }

ocStbHostInBandTunerAGCValue OBJECT-TYPE
SYNTAX Unsigned32(0..100)
UNITS "percentage"
MAX-ACCESS read-only
STATUS current
DESCRIPTION
    "This object allows the manager to retrieve the
    In-band channel AGC value (%). When an In-band
    Carrier Lock is indicated, a value of 0 (zero)
    indicates that the ocStbHost does not compute the
    value."
 ::= { ocStbHostInBandTunerEntry 5 }

ocStbHostInBandTunerSNRValue OBJECT-TYPE
SYNTAX TenthdB
UNITS "tenthdB"
MAX-ACCESS read-only
STATUS current
DESCRIPTION
    "This object allows the manager to retrieve the
    In-band channel SNR value (1/10 dB). When an
    In-band Carrier Lock is indicated, a value of 0
    (zero) indicates that the ocStbHost does not compute
    the value."
 ::= { ocStbHostInBandTunerEntry 6 }

ocStbHostInBandTunerUnerroreds OBJECT-TYPE
SYNTAX Counter32
UNITS "codewords"
MAX-ACCESS read-only
STATUS current
DESCRIPTION
    "Codewords received on this channel without error.
    Discontinuities in the value of this counter can occur
    at reinitialization of the managed system, and at other
    times as indicated by the value of
    ifCounterDiscontinuityTime for the associated ifIndex."
 ::= { ocStbHostInBandTunerEntry 7 }

ocStbHostInBandTunerCorrecteds OBJECT-TYPE
SYNTAX Counter32
UNITS "codewords"
MAX-ACCESS read-only
STATUS current
DESCRIPTION
    "Codewords received on this in-band channel with
    correctable errors. Discontinuities in the value of
    this counter can occur at reinitialization of the
    managed system."
 ::= { ocStbHostInBandTunerEntry 8 }

ocStbHostInBandTunerUncorrectables OBJECT-TYPE
SYNTAX Counter32
UNITS "codewords"
MAX-ACCESS read-only
STATUS current
DESCRIPTION
    "Codewords received on this in-band channel with
    uncorrectable errors.
    Discontinuities in the value of this counter can occur
    at reinitialization of the managed system."

```

```

 ::= { ocStbHostInBandTunerEntry 9 }

ocStbHostInBandTunerCarrierLockLost OBJECT-TYPE
    SYNTAX      Counter32
    MAX-ACCESS  read-only
    STATUS      current
    DESCRIPTION
        "The number of times the ocStbHost has detected carrier
        Lock is lost.
        Discontinuities in the value of this counter can occur
        at reinitialization of the managed system."
 ::= { ocStbHostInBandTunerEntry 10 }

ocStbHostInBandTunerPCRErrors OBJECT-TYPE
    SYNTAX      Counter32
    MAX-ACCESS  read-only
    STATUS      current
    DESCRIPTION
        "The number of times the Program Clock Reference (PCR)
        detected Synchronization errors; e.g., wrong PCR from
        multiplexer, excessive CPR Jitter, etc.
        Discontinuities in the value of this counter can occur
        at reinitialization of the managed system."
 ::= { ocStbHostInBandTunerEntry 11 }

ocStbHostInBandTunerPTSErrors OBJECT-TYPE
    SYNTAX      Counter32
    MAX-ACCESS  read-only
    STATUS      current
    DESCRIPTION
        "The number of Presentation TimeStamp (PTS) packets that
        encounter sequencing errors.
        Discontinuities in the value of this counter can occur
        at reinitialization of the managed system."
 ::= { ocStbHostInBandTunerEntry 12 }

ocStbHostProgramStatusTable OBJECT-TYPE
    SYNTAX      SEQUENCE OF OcStbHostProgramStatusEntry
    MAX-ACCESS  not-accessible
    STATUS      current
    DESCRIPTION
        "A table of current program content being forwarded by the
        ocStbHost."
 ::= { ocStbHostServiceProgramInfo 2 }

ocStbHostProgramStatusEntry OBJECT-TYPE
    SYNTAX      OcStbHostProgramStatusEntry
    MAX-ACCESS  not-accessible
    STATUS      current
    DESCRIPTION
        "There is an entry in this table for each active program
        content path.
        This means that the same program content source and/or
        destination can be associated to multiple A/V interface
        combinations as different entries in this table."
    INDEX { ocStbHostProgramIndex }
 ::= { ocStbHostProgramStatusTable 1 }

OcStbHostProgramStatusEntry ::=
    SEQUENCE {
        ocStbHostProgramIndex
            Unsigned32,
        ocStbHostProgramAVSource
            RowPointer,
        ocStbHostProgramAVDestination
            RowPointer,
        ocStbHostProgramContentSource
    }

```

```

        RowPointer,
    ocStbHostProgramContentDestination
        RowPointer
    }

ocStbHostProgramIndex OBJECT-TYPE
    SYNTAX      Unsigned32 (1..20)
    MAX-ACCESS  not-accessible
    STATUS      current
    DESCRIPTION
        "Index for Program Status Entry Table."
    ::= { ocStbHostProgramStatusEntry 1 }

ocStbHostProgramAVSource OBJECT-TYPE
    SYNTAX      RowPointer
    MAX-ACCESS  read-only
    STATUS      current
    DESCRIPTION
        "Defines the A/V source interface or the ifIndex
        associated with this entry, where the source can be
        interfaces listed in the ifTable such as
        in-band tuners, or a Host Resources Device such as a DVR.
        If the source corresponds to a resource listed in the
        ifTable, this object reports the ifIndex instance of
        the source interface.
        If the source corresponds to a resource listed in
        hrDeviceTable, this object reports the hrDeviceType
        instance of the source interface."
    ::= { ocStbHostProgramStatusEntry 2 }

ocStbHostProgramAVDestination OBJECT-TYPE
    SYNTAX      RowPointer
    MAX-ACCESS  read-only
    STATUS      current
    DESCRIPTION
        "Defines the A/V destination interface or the ifIndex
        associated with this index, where destination can be
        interfaces listed in the ifTable such as USB, Ethernet
        or a Host Resource Device like a DVI A/V interface.
        If the source corresponds to an interface listed in the
        ifTable, this object reports the ifIndex instance of
        the source interface.
        If the source corresponds to a resource listed in the
        hrDeviceTable, this object reports the hrDeviceType
        instance of the source interface."
    ::= { ocStbHostProgramStatusEntry 3 }

ocStbHostProgramContentSource OBJECT-TYPE
    SYNTAX      RowPointer
    MAX-ACCESS  read-only
    STATUS      current
    DESCRIPTION
        "A pointer to the first visible object structure that
        defines the type of content associated to the A/V source
        interface. If the content is from an MPEG2 stream, this
        object points to the first visible object in
        ocStbHostMpeg2ContentEntry.
        Vendor-specific Content models may be defined in the vendor
        enterprise IANA assigned OID.
        This object reports 'zeroDotZero' value if no content
        information is available."
    ::= { ocStbHostProgramStatusEntry 4 }

ocStbHostProgramContentDestination OBJECT-TYPE
    SYNTAX      RowPointer
    MAX-ACCESS  read-only
    STATUS      current

```

```

DESCRIPTION
    "A pointer to the first visible object structure that
    defines the type of content associated to the A/V
    destination interface. For example, if the content for the
    destination interface is an MPEG2 stream
    (e.g., IEEE 1394 SPTS), this object points to the
    first visible object in ocStbHostMpeg2ContentEntry.
    Vendor-specific Content models may be defined in the vendor
    enterprise IANA assigned OID.
    This object reports 'zeroDotZero' value if no content
    information is available."
 ::= { ocStbHostProgramStatusEntry 5 }

--
-- MPEG2 Streaming Content Information
--

ocStbHostMpeg2ContentTable OBJECT-TYPE
    SYNTAX      SEQUENCE OF OcStbHostMpeg2ContentEntry
    MAX-ACCESS  not-accessible
    STATUS      current
    DESCRIPTION
        "Contains information associated to an MPEG-2
        Program carried by an MPEG-2 transport stream.
        Entries in this table can be
        associated to interfaces receiving or forwarding
        MPEG-2 content."
    ::= { ocStbHostServiceProgramInfo 3 }

ocStbHostMpeg2ContentEntry OBJECT-TYPE
    SYNTAX      OcStbHostMpeg2ContentEntry
    MAX-ACCESS  not-accessible
    STATUS      current
    DESCRIPTION
        "The conceptual row for this table."
    INDEX { ocStbHostMpeg2ContentIndex }
    ::= { ocStbHostMpeg2ContentTable 1 }

OcStbHostMpeg2ContentEntry ::=
    SEQUENCE {
        ocStbHostMpeg2ContentIndex
            Unsigned32,
        ocStbHostMpeg2ContentProgramNumber
            Unsigned32,
        ocStbHostMpeg2ContentTransportStreamID
            Unsigned32,
        ocStbHostMpeg2ContentTotalStreams
            Unsigned32,
        ocStbHostMpeg2ContentSelectedVideoPID
            Integer32,
        ocStbHostMpeg2ContentSelectedAudioPID
            Integer32,
        ocStbHostMpeg2ContentOtherAudioPIDs
            TruthValue,
        ocStbHostMpeg2ContentCCIValue
            INTEGER,
        ocStbHostMpeg2ContentAPSVValue
            INTEGER,
        ocStbHostMpeg2ContentCITStatus
            TruthValue,
        ocStbHostMpeg2ContentBroadcastFlagStatus
            TruthValue,
        ocStbHostMpeg2ContentEPNStatus
            TruthValue
    }

ocStbHostMpeg2ContentIndex OBJECT-TYPE

```

```

SYNTAX      Unsigned32 (1..20)
MAX-ACCESS  not-accessible
STATUS      current
DESCRIPTION
    "The unique identifier for the Mpeg2 Content entries in
    this table."
 ::= { ocStbHostMpeg2ContentEntry 1 }

ocStbHostMpeg2ContentProgramNumber OBJECT-TYPE
SYNTAX      Unsigned32
MAX-ACCESS  read-only
STATUS      current
DESCRIPTION
    "The program Number associated with active content within
    the ocStbHost."
 ::= { ocStbHostMpeg2ContentEntry 2 }

ocStbHostMpeg2ContentTransportStreamID OBJECT-TYPE
SYNTAX      Unsigned32
MAX-ACCESS  read-only
STATUS      current
DESCRIPTION
    "Defines the transport stream ID associated with the
    program number."
 ::= { ocStbHostMpeg2ContentEntry 3 }

ocStbHostMpeg2ContentTotalStreams OBJECT-TYPE
SYNTAX      Unsigned32
UNITS       "streams"
MAX-ACCESS  read-only
STATUS      current
DESCRIPTION
    "Defines the total number of elementary streams associated
    with the program number."
 ::= { ocStbHostMpeg2ContentEntry 4 }

ocStbHostMpeg2ContentSelectedVideoPID OBJECT-TYPE
SYNTAX      Integer32 (-1 | 1..8191)
MAX-ACCESS  read-only
STATUS      current
DESCRIPTION
    "This object allows the manager to retrieve the
    PID associated to the selected video
    stream. The value '-1' indicates that no video stream
    is being selected or identified.
    The value is the 13-bit PID value expressed in decimal."
 ::= { ocStbHostMpeg2ContentEntry 5 }

ocStbHostMpeg2ContentSelectedAudioPID OBJECT-TYPE
SYNTAX      Integer32 (-1 | 1..8191)
MAX-ACCESS  read-only
STATUS      current
DESCRIPTION
    "The selected audio PID.
    The value '-1' indicates no audio stream identified."
 ::= { ocStbHostMpeg2ContentEntry 6 }

ocStbHostMpeg2ContentOtherAudioPIDs OBJECT-TYPE
SYNTAX      TruthValue
MAX-ACCESS  read-only
STATUS      current
DESCRIPTION
    "Then value 'true' indicates the MPEG-2 program
    has more than one audio PID.
    'false' indicates the MPEG-2 program has only one
    audio PID."
 ::= { ocStbHostMpeg2ContentEntry 7 }

```

```

ocStbHostMpeg2ContentCCIValue OBJECT-TYPE
    SYNTAX      INTEGER
                {
                    copyFreely(0),
                    copyNoMore(1),
                    copyOneGeneration(2),
                    copyNever(3),
                    undefined(4)
                }
    MAX-ACCESS  read-only
    STATUS      current
    DESCRIPTION
        "This value allows the manager to retrieve the
        encryption Mode Indication (EMI) Bits of the
        Copy Control Information (CCI) byte associated
        with the service."
    ::= { ocStbHostMpeg2ContentEntry 8 }

ocStbHostMpeg2ContentAPSValue OBJECT-TYPE
    SYNTAX      INTEGER
                {
                    type1(1),
                    type2(2),
                    type3(3),
                    noMacrovision(4),
                    notDefined(5)
                }
    MAX-ACCESS  read-only
    STATUS      current
    DESCRIPTION
        "This value allows the manager to retrieve the
        Analog Protection System (APS) bits of the
        Copy Control Information (CCI) byte
        associated with the service.
        'type1' indicates AGC ON, split burst OFF
        'type2' indicates AGC ON, 2-line split burst
        'type3' indicates AGC ON, 4-line split burst."
    ::= { ocStbHostMpeg2ContentEntry 9 }

ocStbHostMpeg2ContentCITStatus OBJECT-TYPE
    SYNTAX      TruthValue
    MAX-ACCESS  read-only
    STATUS      current
    DESCRIPTION
        "This value allows the manager to retrieve the state
        of the Constrained Image Trigger(CIT).

        'true' indicates image constraint required.
        'false' indicates image constraint not asserted."
    ::= { ocStbHostMpeg2ContentEntry 10 }

ocStbHostMpeg2ContentBroadcastFlagStatus OBJECT-TYPE
    SYNTAX      TruthValue
    MAX-ACCESS  read-only
    STATUS      current
    DESCRIPTION
        "This value allows the manager to retrieve the state
        of Broadcast Flag in the source interface.
        'true' indicates Broadcast Flag present.
        'false' indicates Broadcast Flag not present."
    ::= { ocStbHostMpeg2ContentEntry 11 }

ocStbHostMpeg2ContentEPNStatus OBJECT-TYPE
    SYNTAX      TruthValue
    MAX-ACCESS  read-only
    STATUS      current

```

```

DESCRIPTION
    "This object allows the manager to retrieve the
    EPN status of the MPEG stream. 'true' indicates
    that EPN is asserted."
 ::= { ocStbHostMpeg2ContentEntry 12 }

--
-- Analog Video Table
--

ocStbHostAnalogVideoTable OBJECT-TYPE
    SYNTAX      SEQUENCE OF OcStbHostAnalogVideoEntry
    MAX-ACCESS  not-accessible
    STATUS      current
    DESCRIPTION
        "Contains information about the Analog Video signal.
        Entries in this table can be associated to interfaces
        receiving or forwarding analog content."
    ::= { ocStbHostServiceProgramInfo 4 }

ocStbHostAnalogVideoEntry OBJECT-TYPE
    SYNTAX      OcStbHostAnalogVideoEntry
    MAX-ACCESS  not-accessible
    STATUS      current
    DESCRIPTION
        "The conceptual row for this table."
    INDEX { ocStbHostAVInterfaceIndex }
    ::= { ocStbHostAnalogVideoTable 1 }

OcStbHostAnalogVideoEntry ::=
    SEQUENCE {
        ocStbHostAnalogVideoProtectionStatus INTEGER
    }

ocStbHostAnalogVideoProtectionStatus OBJECT-TYPE
    SYNTAX      INTEGER {
        copyProtectionOff(0),
        splitBurstOff(1),
        twoLineSplitBurst(2),
        fourLineSplitBurst(3)
    }
    MAX-ACCESS  read-only
    STATUS      current
    DESCRIPTION
        "The analog protection system (APS) of this Video content
        entry. The possible values are:
        'copyProtectionOff' means the Macrovision Analog protection
        is off
        'splitBurstOff' means the AGC (Automatic Gain Control)
        is on and the split burst is off.
        'twoLineSplitBurst' means AGC is on with two-line
        split burst.
        'fourLineSplitBurst' means AGC is on with four-line
        split burst.
        This object is instantiated only for A/V output interfaces
        that support APS like but not limited to:
        'ocStbHostRfOutCh', 'ocStbHostSVideoOut' and
        'ocStbHostBbVideoOut'.
        The A/V interfaces 'ocStbHostHdComponentOut'
        only support 'splitBurstOff' APS mode for the video formats
        'format480i' and 'format480p'."
    ::= { ocStbHostAnalogVideoEntry 1 }

--
-- EAS Objects
--

```

```

ocStbHostEasObjects OBJECT IDENTIFIER ::= { ocStbHostSystem 3 }
ocStbHostEasCodes OBJECT IDENTIFIER ::= { ocStbHostEasObjects 1 }

ocStbEasMessageStateCode OBJECT-TYPE
    SYNTAX      Unsigned32 (0..99)
    MAX-ACCESS  read-only
    STATUS      current
    DESCRIPTION
        "This object allows the manager to retrieve the
        EAS State Code utilized by the STB. A
        value of 0 indicates that the code is not
        defined, thus the eSTB does not discriminate
        any State Code defined in an EAS message."
    REFERENCE
        "SCTE-18"
    ::= { ocStbHostEasCodes 1 }

ocStbEasMessageCountyCode OBJECT-TYPE
    SYNTAX      Unsigned32 (0..999)
    MAX-ACCESS  read-only
    STATUS      current
    DESCRIPTION
        "This object allows the manager to retrieve the
        EAS County Code utilized by the STB. A
        value of 0 indicates that the code is not
        defined, thus the eSTB ignores any County
        Code defined in an EAS message."
    REFERENCE
        "SCTE-18"
    ::= { ocStbHostEasCodes 2 }

ocStbEasMessageCountySubdivisionCode OBJECT-TYPE
    SYNTAX      Unsigned32 (0..9)
    MAX-ACCESS  read-only
    STATUS      current
    DESCRIPTION
        "This object allows the manager to retrieve the
        EAS County Sub Code utilized by the STB. A
        value of 0 indicates that the code is not
        defined, thus the eSTB ignores it and any County
        Subdivision Code defined in an EAS message is accepted."
    REFERENCE
        "SCTE-18"
    ::= { ocStbHostEasCodes 3 }

--
-- STB security subsystem
--

ocStbHostSecuritySubSystem OBJECT IDENTIFIER ::= { ocStbHostMibObjects 2 }

ocStbHostSecurityIdentifier OBJECT-TYPE
    SYNTAX      SnmpAdminString
    MAX-ACCESS  read-only
    STATUS      current
    DESCRIPTION
        "The security identifier of the ocStbHost.
        This object represents the value 'Host Security ID'
        sent in the CableCARD Status report apdu."
    ::= { ocStbHostSecuritySubSystem 2 }

ocStbHostCASystemIdentifier OBJECT-TYPE
    SYNTAX      SnmpAdminString
    MAX-ACCESS  read-only
    STATUS      current
    DESCRIPTION
        "Conditional access system identifier defined by DVB

```

```

        and MPEG. This object represents the value 'Host CA System
        Identifier' sent in the CableCARD Status report apdu."
 ::= { ocStbHostSecuritySubSystem 3 }

ocStbHostCAType OBJECT-TYPE
    SYNTAX      INTEGER {
                other(1),
                embedded(2),
                cablecard(3),
                downloadable(4)
                }
    MAX-ACCESS  read-only
    STATUS      current
    DESCRIPTION
        "The Conditional Access (CA) supported by
        the host device.
        'other' means a CA which is not described by one of
        the other enumerations in this list.
        'embedded' means a vendor-specific embedded CA
        'cablecard' means OpenCable CableCARD is supported.
        'downloadable' means software downloadable CA is
        supported."
 ::= { ocStbHostSecuritySubSystem 4 }

--
-- STB Host Software objects
--

ocStbHostSoftware OBJECT IDENTIFIER ::= { ocStbHostMibObjects 3 }

--
-- ocStbHost device Software Requirements
--

ocStbHostDeviceSoftwareBase OBJECT IDENTIFIER ::=
    { ocStbHostSoftware 1 }
ocStbHostSoftwareDownloadStatus OBJECT IDENTIFIER ::=
    { ocStbHostSoftware 2 }

--
-- Software versions
--

ocStbHostSoftwareVersion OBJECT-TYPE
    SYNTAX      SnmpAdminString
    MAX-ACCESS  read-only
    STATUS      current
    DESCRIPTION
        "The platform code version currently operating in this
        device. This object should be in the syntax used by the
        individual vendor to identify software versions. The
        device must return a string descriptive of the current
        software load."
 ::= { ocStbHostDeviceSoftwareBase 1 }

ocStbHostSoftwareOCAPVersion OBJECT-TYPE
    SYNTAX      SnmpAdminString
    MAX-ACCESS  read-only
    STATUS      current
    DESCRIPTION
        "This object returns a string indicating the latest version
        of the OCAP profile supported by this device, e.g., '1.0'."
 ::= { ocStbHostDeviceSoftwareBase 2 }

--
-- Software Download Status
--

```

```

ocStbHostSoftwareImageStatus OBJECT-TYPE
    SYNTAX          INTEGER
                    {
                        imageAuthorized(1),
                        imageCorrupted(2),
                        imageCertFailure(3),
                        imageMaxDownloadRetry(4),
                        imageMaxRebootRetry(5)
                    }
    MAX-ACCESS      read-only
    STATUS          current
    DESCRIPTION
        "This object details the image status recently downloaded
        'imageAuthorized' means the image is valid.
        'imageCorrupted' means the image is invalid.
        'imageCertFailure' means CVC authentication has failed.
        'imageMaxDownloadRetry' means the maximum number of code
        file download retries has been reached. When the value of
        this object is imageMaxDownloadRetry(4), the value of
        ocStbHostSoftwareCodeDownloadStatus must be
        downloadingFailed(3).
        'imageMaxRebootRetry' means the maximum number of reboots
        has occurred after code file download."
    ::= { ocStbHostSoftwareDownloadStatus 1 }

ocStbHostSoftwareCodeDownloadStatus OBJECT-TYPE
    SYNTAX          INTEGER
                    {
                        downloadingStarted(1),
                        downloadingComplete(2),
                        downloadingFailed(3)
                    }
    MAX-ACCESS      read-only
    STATUS          current
    DESCRIPTION
        "This object details the download status
        of the target image.
        'downloadingComplete' means the image download was
        successful.
        'downloadingFailed' means the image download failed."
    ::= { ocStbHostSoftwareDownloadStatus 2 }

ocStbHostSoftwareCodeObjectName OBJECT-TYPE
    SYNTAX          SnmpAdminString
    MAX-ACCESS      read-only
    STATUS          current
    DESCRIPTION
        "The file name of the software image to be loaded into this
        device. This object value may optionally contain server
        and path information about the file name when applicable.
        If unknown, the string '(unknown)' is returned."
    ::= { ocStbHostSoftwareDownloadStatus 3 }

--
-- ocStbHost Device Security Requirements
--

ocStbHostStatus OBJECT IDENTIFIER ::= { ocStbHostMibObjects 4 }

ocStbHostPower OBJECT IDENTIFIER ::= { ocStbHostStatus 1 }

ocStbHostPowerStatus OBJECT-TYPE
    SYNTAX          INTEGER
                    {
                        powerOn(1),
                        standby(2)
                    }

```

```

    }
    MAX-ACCESS read-only
    STATUS current
    DESCRIPTION
        "Indicates the current power status of the ocStbHost."
    ::= { ocStbHostPower 1 }

ocStbHostAcOutletStatus OBJECT-TYPE
    SYNTAX INTEGER
        {
            unSwitched(1),
            switchedOn(2),
            switchedOff(3),
            notInstalled(4)
        }
    MAX-ACCESS read-only
    STATUS current
    DESCRIPTION
        "Indicates the AC accessory power outlet status of the
        ocStbHost.
        'unSwitched'
        Indicates AC accessory power outlet is present and provides
        power as long as the ocStbHost is connected to a powered AC
        outlet.
        'switchedOn'
        Indicates the AC accessory power outlet is currently
        switched to ON and provides power as long as the value of
        ocStbHostPowerStatus is 'powerOn'.
        'switchedOff'
        Indicates the AC accessory power outlet is currently
        switched to OFF and does not provide power.
        'notInstalled'
        Indicates no AC accessory power outlet is present in the
        ocStbHost."
    ::= { ocStbHostPower 2 }

ocStbHostUserSettings OBJECT IDENTIFIER ::= { ocStbHostStatus 2 }

ocStbHostUserSettingsPreferredLanguage OBJECT-TYPE
    SYNTAX DisplayString (SIZE(3))
    MAX-ACCESS read-only
    STATUS current
    DESCRIPTION
        "The preferred language of the audio streams indicated
        as the 3-octet code specified in ISO 639-2."
    REFERENCE
        "ISO 639.2 Codes for the Representation of Names of
        Languages available at
        http://www.loc.gov/standards/iso639-2/langhome.html."
    ::= { ocStbHostUserSettings 1 }

-- Conformance information

ocStbHostConformance OBJECT IDENTIFIER ::= { ocStbHostMibModule 2 }
ocStbHostMIBCompliances OBJECT IDENTIFIER ::= { ocStbHostConformance 1 }
ocStbHostMIBGroups OBJECT IDENTIFIER ::= { ocStbHostConformance 2 }

-- Compliance statements

ocStbHostMIBCompliance MODULE-COMPLIANCE
    STATUS current
    DESCRIPTION
        "The requirements for conformance to the OpenCable
        Set-top HOST MIB."
    MODULE -- this module
    MANDATORY-GROUPS {
        ocStbHostSystemGroup,

```

```

        ocStbHostSoftwareGroup,
        ocStbHostStatusGroup,
        ocStbHostSecuritySubSystemGroup
    }

```

OBJECT ocStbHostInBandTunerFrequency

SYNTAX Unsigned32(47000000..86200000)

DESCRIPTION

"For a cable plant using a North American Sub-Split channel plan, the range of 54MHZ to 860MHZ is appropriated. The lower range of 47MHZ and upper edge of 862MHZ accommodates some European channel plans. Revisions of this object conformance will be defined when the corresponding requirements and frequency allocations change."

::= { ocStbHostMIBCompliances 1 }

ocStbHostSystemGroup OBJECT-GROUP

OBJECTS

```

    {
        ocStbHostSerialNumber,
        ocStbHostHostID,
        ocStbHostCapabilities,
        ocStbHostAVInterfaceType,
        ocStbHostAVInterfaceDesc,
        ocStbHostAVInterfaceStatus,
        ocStbHostInBandTunerModulationMode,
        ocStbHostInBandTunerFrequency,
        ocStbHostInBandTunerInterleaver,
        ocStbHostInBandTunerPower,
        ocStbHostInBandTunerAGCValue,
        ocStbHostInBandTunerSNRValue,
        ocStbHostInBandTunerUnerrored,
        ocStbHostInBandTunerCorrected,
        ocStbHostInBandTunerUncorrectable,
        ocStbHostInBandTunerCarrierLockLost,
        ocStbHostInBandTunerPCRErrors,
        ocStbHostInBandTunerPTSErrors,
        ocStbHostIEEE1394ActiveNodes,
        ocStbHostIEEE1394DataXmission,
        ocStbHostIEEE1394DTCPSStatus,
        ocStbHostIEEE1394LoopStatus,
        ocStbHostIEEE1394RootStatus,
        ocStbHostIEEE1394CycleIsMaster,
        ocStbHostIEEE1394IRMStatus,
        ocStbHostIEEE1394AudioMuteStatus,
        ocStbHostIEEE1394VideoMuteStatus,
        ocStbHostIEEE1394ConnectedDevicesAVInterfaceIndex,
        ocStbHostIEEE1394ConnectedDevicesSubUnitType,
        ocStbHostIEEE1394ConnectedDevicesEui64,
        ocStbHostIEEE1394ConnectedDevicesADSourceSelectSupport,
        ocStbHostDVIHDMIOutputType,
        ocStbHostDVIHDMIConnectionStatus,
        ocStbHostDVIHDMIRepeaterStatus,
        ocStbHostDVIHDMIVideoXmissionStatus,
        ocStbHostDVIHDMIHDCPStatus,
        ocStbHostDVIHDMIVideoMuteStatus,
        ocStbHostDVIHDMIOutputFormat,
        ocStbHostDVIHDMIAspectRatio,
        ocStbHostDVIHDMIAudioFormat,
        ocStbHostDVIHDMIAudioSampleRate,
        ocStbHostDVIHDMIAudioChannelCount,
        ocStbHostDVIHDMIAudioMuteStatus,
        ocStbHostSPDIFAudioFormat,
        ocStbHostSPDIFAudioMuteStatus,
        ocStbHostComponentVideoConstrainedStatus,
        ocStbHostComponentOutputFormat,
        ocStbHostComponentAspectRatio,
        ocStbHostComponentVideoMuteStatus,
    }

```

```

        ocStbHostRFChannelOut,
        ocStbHostRFChannelOutAudioMuteStatus,
        ocStbHostRFChannelOutVideoMuteStatus,
        ocStbEasMessageStateCode,
        ocStbEasMessageCountyCode,
        ocStbEasMessageCountySubdivisionCode,
        ocStbHostProgramAVSource,
        ocStbHostProgramAVDestination,
        ocStbHostProgramContentSource,
        ocStbHostProgramContentDestination,
        ocStbHostMpeg2ContentProgramNumber,
        ocStbHostMpeg2ContentTransportStreamID,
        ocStbHostMpeg2ContentTotalStreams,
        ocStbHostMpeg2ContentSelectedVideoPID,
        ocStbHostMpeg2ContentSelectedAudioPID,
        ocStbHostMpeg2ContentOtherAudioPIDs,
        ocStbHostMpeg2ContentCCIValue,
        ocStbHostMpeg2ContentAPSVValue,
        ocStbHostMpeg2ContentCITStatus,
        ocStbHostMpeg2ContentBroadcastFlagStatus,
        ocStbHostMpeg2ContentEPNStatus,
        ocStbHostAnalogVideoProtectionStatus
    }
STATUS      current
DESCRIPTION
    "Defines the objects contained with the ocStbHost System
    Group."
 ::= { ocStbHostMIBGroups 1 }

ocStbHostSoftwareGroup OBJECT-GROUP
OBJECTS     {
            ocStbHostSoftwareImageStatus,
            ocStbHostSoftwareCodeDownloadStatus,
            ocStbHostSoftwareVersion,
            ocStbHostSoftwareCodeObjectName,
            ocStbHostSoftwareOCAPVersion
            }
STATUS      current
DESCRIPTION
    "The ocStbHost Software group."
 ::= { ocStbHostMIBGroups 2 }

ocStbHostStatusGroup OBJECT-GROUP
OBJECTS     {
            ocStbHostPowerStatus,
            ocStbHostAcOutletStatus,
            ocStbHostUserSettingsPreferredLanguage
            }
STATUS      current
DESCRIPTION
    "The object group related to multiple ocStbHost status."
 ::= { ocStbHostMIBGroups 3 }

ocStbHostSecuritySubSystemGroup OBJECT-GROUP
OBJECTS     {
            ocStbHostSecurityIdentifier,
            ocStbHostCASystemIdentifier,
            ocStbHostCAType
            }
STATUS      current
DESCRIPTION
    "The ocStbHost Security Subsystem group."
 ::= { ocStbHostMIBGroups 4 }
END

```

APPENDIX I Revision History (Informative)

The following ECNs were incorporated into OC-SP-HOST2.0-CFR-I02-041119:

ECN	Description	Date
HOST2.0-CFR-N-04.0696-1	Addition of issued CableCARD Interface and Copy Protection Specs to normative references	11/5/04

The following ECNs were incorporated into OC-SP-HOST2.0-CFR-I03-050121:

ECN	Description	Date
HOST2.0-CFR-N-04.0702-3	DVI/HDMI Requirement changes, modifications and deletions	12/3/04
HOST2.0-CFR-N-04.0710-2	DSG packet buffer requirement	12/3/04
HOST2.0-CFR-N-04.0711-2	Require DOCSIS 2.0 for Host 2.0 cable modem	12/10/04

The following ECNs were incorporated into OC-SP-HOST2.0-CFR-I04-050415:

ECN	Description	Date
HOST2.0-CFR-N-04.0736-2	Remove MPEG encoder requirements associated with IEEE-1394	4/12/05
HOST2.0-CFR-N-04.0743-1	Update references to CableCARD Interface and Copy Protection specs	4/14/05

The following ECNs were incorporated into OC-SP-HOST2.0-CFR-I05-050503:

ECN	Description	Date
HOST2.0-CFR-N-04.0764-1	Put DOCSIS 1.1 requirement back into Host 2.0 spec (DOCSIS 2.0 requirement not effective until 3/1/06)	5/2/05

The following ECNs were incorporated into OC-SP-HOST2.0-CFR-I06-050708:

ECN	Description	Date
HOST2.0-CFR-N-04.0757-1	MPEG-2 HD decoding requirement	6/6/05
HOST2.0-CFR-N-04.0795-1	Wireless keyboard requirements for Host 2.0 devices	6/24/05
HOST2.0-CFR-N-05.0756-4	DHCP operation for Host 2.0	7/1/05
HOST2.0-CFR-N-05.0768-4	Input Device function keys	7/6/05

The following ECNs were incorporated into OC-SP-HOST2.0-CFR-I07-060126:

ECN	Description	Date
HOST2.0-CFR-N-05.0822-2	Require Generic Diagnostic Resource Capability	1/13/06
HOST2.0-CFR-N-05.0824-3	Mandate Multi-stream CARD interface on Host 2.0 devices	12/10/05
HOST2.0-CFR-N-05.0839-3	Delete references in upstream transmission characteristics not in SCTE 55-1 and 55-2	1/13/06
HOST2.0-CFR-N-05.0855-3	OpenCable Host 2.0 MIB Requirements	1/13/06

The following ECNs were incorporated into OC-SP-HOST2.0-CFR-I08-060413:

ECN	Description	Date
HOST2.0-CFR-N-05.0845-6	Add a specific requirement for granting DSG flow in OOB mode	3/3/06
HOST2.0-CFR-N-06.0880-4	Host IP Provisioning	3/30/06