

**PacketCable™**

## **Residential SIP Telephony E-DVA Specification**

**PKT-SP-RST-E-DVA-I03-080425**

**ISSUED**

### **Notice**

This PacketCable specification is the result of a cooperative effort undertaken at the direction of Cable Television Laboratories, Inc. for the benefit of the cable industry and its customers. This document may contain references to other documents not owned or controlled by CableLabs. Use and understanding of this document may require access to such other documents. Designing, manufacturing, distributing, using, selling, or servicing products, or providing services, based on this document may require intellectual property licenses from third parties for technology referenced in this document.

Neither CableLabs nor any member company is responsible to any party for any liability of any nature whatsoever resulting from or arising out of use or reliance upon this document, or any document referenced herein. This document is furnished on an "AS IS" basis and neither CableLabs nor its members provides any representation or warranty, express or implied, regarding the accuracy, completeness, noninfringement, or fitness for a particular purpose of this document, or any document referenced herein.

© Copyright 2007-2008 Cable Television Laboratories, Inc.  
All rights reserved.

## Document Status Sheet

<b>Document Control Number:</b>	PKT-SP-RST-E-DVA-I03-080425			
<b>Document Title:</b>	Residential SIP Telephony E-DVA Specification			
<b>Revision History:</b>	I01 - Released 9/27/06 I02 - Released 9/25/07 I03 - Released 4/25/08			
<b>Date:</b>	April 25, 2008			
<b>Status:</b>	<del>Work in Progress</del>	<del>Draft</del>	<del>Issued</del>	<del>Closed</del>
<b>Distribution Restrictions:</b>	<del>Author Only</del>	<del>CL/Member</del>	<del>CL/Member/ Vendor</del>	<del>Public</del>

### Key to Document Status Codes:

<b>Work in Progress</b>	An incomplete document, designed to guide discussion and generate feedback that may include several alternative requirements for consideration.
<b>Draft</b>	A document in specification format considered largely complete, but lacking review by Members and vendors. Drafts are susceptible to substantial change during the review process.
<b>Issued</b>	A stable document, which has undergone rigorous member and vendor review and is suitable for product design and development, cross-vendor interoperability, and for certification testing.
<b>Closed</b>	A static document, reviewed, tested, validated, and closed to further engineering change requests to the specification through CableLabs.

### Trademarks:

CableLabs®, DOCSIS®, EuroDOCSIS™, eDOCSIS™, M-CMTS™, PacketCable™, EuroPacketCable™, PCMM™, CableHome®, CableOffice™, OpenCable™, OCAP™, CableCARD™, M-Card™, DCAS™, and tru2way™ are trademarks of Cable Television Laboratories, Inc.

# Contents

<b>1</b>	<b>SCOPE</b>	<b>1</b>
1.1	INTRODUCTION AND PURPOSE	1
1.2	REQUIREMENTS	1
<b>2</b>	<b>REFERENCES</b>	<b>2</b>
2.1	NORMATIVE REFERENCES	2
2.2	INFORMATIVE REFERENCES	3
2.3	REFERENCE ACQUISITION	4
<b>3</b>	<b>TERMS AND DEFINITIONS</b>	<b>5</b>
<b>4</b>	<b>ABBREVIATIONS AND ACRONYMS</b>	<b>6</b>
<b>5</b>	<b>OVERVIEW</b>	<b>7</b>
5.1	PACKETCABLE OVERVIEW	7
5.2	SERVICE GOALS	7
5.3	PACKETCABLE REFERENCE ARCHITECTURE	7
5.4	EMBEDDED DIGITAL VOICE ADAPTOR	7
<b>6</b>	<b>E-DVA POWER REQUIREMENTS</b>	<b>9</b>
6.1	POWER CONSIDERATIONS	9
6.2	TYPICAL E-DVA TRAFFIC MODEL	9
6.3	SERVICE REQUIREMENTS UNDER AC FAIL CONDITIONS	9
6.4	LOCAL POWERING WITH BATTERY BACKUP	9
<b>7</b>	<b>E-DVA ANALOG PORT REQUIREMENTS</b>	<b>10</b>
7.1	LOOP START SIGNALING	10
7.1.1	<i>DC Supervisory Range</i>	10
7.1.2	<i>Idle State Voltage</i>	10
7.1.3	<i>Loop Closure Detection</i>	11
7.1.4	<i>Loop Open Detection</i>	11
7.1.5	<i>Off-Hook Delay</i>	11
7.1.6	<i>Flash Hook Delay</i>	11
7.1.7	<i>On-Hook Delay</i>	11
7.1.8	<i>Ringsplash</i>	11
7.1.9	<i>Distinctive Alerting</i>	11
7.1.10	<i>Transmission Path</i>	12
7.2	GENERAL SUPERVISION	12
7.2.1	<i>Off-Hook Loop Current</i>	12
7.2.2	<i>Immunity to Line Crosses</i>	12
7.2.3	<i>System Generated Open Intervals</i>	12
7.2.4	<i>Open Switching Interval Distortion</i>	12
7.2.5	<i>Answer Supervision Signal (AnsSup)</i>	13
7.2.6	<i>Dial Pulsing</i>	13
7.2.7	<i>DTMF Signaling</i>	13
7.2.8	<i>Dialtone Removal</i>	13
7.3	GENERAL RINGING	14
7.3.1	<i>Alerting Signals</i>	14
7.3.2	<i>Ringling Delay</i>	14
7.3.3	<i>Ringling Source</i>	14
7.3.4	<i>Ringling Capability</i>	14
7.3.5	<i>Ringling Capacity</i>	14
7.3.6	<i>Ring Trip</i>	14

7.3.7 *Ring Trip Detect Delay*..... 14

7.3.8 *Ring Trip Immunity*..... 15

7.4 VOICE GRADE ANALOG TRANSMISSION ..... 15

7.4.1 *Input Impedance* ..... 15

7.4.2 *Hybrid Balance*..... 15

7.4.3 *Longitudinal Balance*..... 15

7.4.4 *E-DVA Loss* ..... 16

7.4.5 *E-DVA Loss Tolerance* ..... 16

7.4.6 *Frequency Response* ..... 16

7.4.7 *60 Hz Loss* ..... 16

7.4.8 *Amplitude Tracking* ..... 17

7.4.9 *Overload Compression*..... 17

7.4.10 *Idle Channel Noise*..... 17

7.4.11 *Signal to Distortion*..... 17

7.4.12 *Impulse Noise*..... 17

7.4.13 *Intermodulation Distortion*..... 18

7.4.14 *Single Frequency Distortion*..... 18

7.4.15 *Generated Tones*..... 18

7.4.16 *Peak-to-Average Ratio*..... 18

7.4.17 *Channel Crosstalk* ..... 18

7.5 OUT OF SERVICE REQUIREMENTS ..... 18

7.5.1 *E-DVA On Hook State* ..... 19

7.5.2 *E-DVA Off Hook State* ..... 20

7.5.3 *DTMF Signaling*..... 20

7.5.4 *Expanded Network Service Outages*..... 20

7.6 MESSAGE WAITING INDICATOR..... 20

**8 CLIENT REQUIREMENTS ..... 22**

8.1 PROVISIONING ..... 22

8.2 SECURITY ..... 22

8.2.1 *Authentication*..... 22

8.2.2 *Signaling Security*..... 22

8.3 NAT/FIREWALL TRAVERSAL ..... 22

8.4 CODECS ..... 23

8.5 LOOPBACK TEST CAPABILITY ..... 24

8.5.1 *Test Call Request Encoding*..... 24

8.5.2 *E-DVA Requirements on Reception of a Loopback Request*..... 24

8.6 ANNOUNCEMENTS ..... 25

8.6.1 *Feature Description*..... 25

8.6.2 *Tone Media*..... 25

8.6.3 *Tone and Announcement Media*..... 27

**9 E-DVA MONITORING REQUIREMENTS ..... 29**

9.1 ECM MONITORING ..... 29

9.2 E-DVA MONITORING ..... 29

9.3 BATTERY-BACKUP MONITORING ..... 29

**APPENDIX I ACKNOWLEDGEMENTS ..... 30**

**APPENDIX II REVISION HISTORY ..... 31**

## Figures

FIGURE 1 - TELEPHONY SERVICES OVER THE DATA-OVER-CABLE SYSTEM .....	7
FIGURE 2 - E-DVA PROTOCOLS .....	8

## Tables

TABLE 1 - E-DVA TRAFFIC MODEL .....	9
TABLE 2 - E-DVA NETWORK DISCONNECT SIGNALING EVENT .....	12
TABLE 3 - E-DVA ANSWER SUPERVISION EVENT .....	13
TABLE 4 - DTMF RELAY OFFER .....	13
TABLE 5 - E-DVA PROVISIONED LOSS PLAN .....	16
TABLE 6 - NETWORK/E-DVA ON HOOK IN/OUT OF SERVICE .....	19
TABLE 7 - MWI SIGNAL TYPES .....	21
TABLE 8 - E-DVA CODEC PROVISIONING .....	23
TABLE 9 - ANNOUNCEMENT TONE IDENTIFIERS .....	25
TABLE 10 - ANNOUNCEMENT IDENTIFIERS .....	27
TABLE 11 - ANNOUNCEMENT TYPES .....	28

This page left blank intentionally.

# 1 SCOPE

## 1.1 Introduction and Purpose

This specification defines the embedded Digital Voice Adaptor (E-DVA) requirements for the analog interface and for powering of the E-DVA. An embedded DVA is a DOCSIS cable modem (CM) integrated with a PacketCable DVA.

The purpose of this specification is to define a set of requirements that will enable a sufficiently reliable service to meet assumed consumer expectations related to residential telephony. These assumed expectations include constant availability, including availability during power failure at the customer's premise and access to emergency services (911, etc.).

## 1.2 Requirements

Throughout this document, the words that are used to define the significance of particular requirements are capitalized. These words are:

"MUST"	This word means that the item is an absolute requirement of this specification.
"MUST NOT"	This phrase means that the item is an absolute prohibition of this specification.
"SHOULD"	This word means that there may exist valid reasons in particular circumstances to ignore this item, but the full implications should be understood and the case carefully weighed before choosing a different course.
"SHOULD NOT"	This phrase means that there may exist valid reasons in particular circumstances when the listed behavior is acceptable or even useful, but the full implications should be understood and the case carefully weighed before implementing any behavior described with this label.
"MAY"	This word means that this item is truly optional. One vendor may choose to include the item because a particular marketplace requires it or because it enhances the product, for example; another vendor may omit the same item.

## 2 REFERENCES

### 2.1 Normative References

In order to claim compliance with this specification, it is necessary to conform to the following standards and other works as indicated, in addition to the other requirements of this specification. Notwithstanding, intellectual property rights may be required to use or implement such normative references.

[ANSI T1.401]	ANSI T1.401, Network to Customer Installation Interfaces - Analog Voice grade Switched Access Lines Using Loop-Start and Ground Start Signaling, 2000.
[CODEC-MEDIA]	PacketCable Codec-Media Specification, PKT-SP-CODEC-MEDIA-I04-080425, April 24, 2008, Cable Television Laboratories, Inc.
[DOCSIS OSSIV2.0]	DOCSIS Operations Support System Interface Specification, CM-SP-OSSIV2.0-I10-070803, August 3, 2007, Cable Television Laboratories, Inc.
[DOCSIS RFIv2.0]	DOCSIS Radio Frequency Interface Specification, DOCSIS CM-SP-RFIv2.0-I13-080215, February 15, 2008, Cable Television Laboratories, Inc.
[eDOCSIS]	eDOCSIS Specification, CM-SP-eDOCSIS-I14-080215, February 15, 2008, Cable Television Laboratories, Inc.
[EN 300 659-1]	ETSI EN 300 659-1, Access and Terminals (AT); Analogue access to the Public Switched Telephone Network (PSTN); Subscriber line protocol over the local loop for display (and related) services; Part 1: On-hook data transmission, January 2001.
[EN 300 659-3]	ETSI EN 300 659-3, Access and Terminals (AT); Analogue access to the Public Switched Telephone Network (PSTN); Subscriber line protocol over the local loop for display (and related) services; Part 3: Data link message and parameter codings, January 2001.
[G 168]	ITU-T Rec. G.168 (08/04), Digital network echo cancellers.
[G 711]	ITU-T Rec. G.711 (11/88), Pulse code modulation (PCM) of voice frequencies.
[GR 30]	Telcordia GR-30-CORE, LSSGR: Voiceband Data Transmission Interface, December 1998, FR-64.
[GR 57]	Telcordia GR-57-CORE, Issue 1, October 2001, Functional Criteria for Digital Loop Carrier (DLC) Systems.
[GR 303]	Telcordia GR-202, Issue 4, Integrated Digital Loop Carrier System Generic Requirements, Objectives, and Interface, December 2002.
[GR 499]	Telcordia GR-499-CORE, Issue 4, Transport Systems Generic Requirements (TSGR): Common Requirements, September 2004.
[GR 506]	Telcordia GR-506-CORE, LSSGR: Signaling for Analog Interfaces, November, 1996, FR-64.
[GR 909]	Telcordia GR-909-CORE, Issue 2, Generic Requirements and Objectives for Fiber in the Loop (FITL) Systems, December 2004.
[GR 1089]	Telcordia GR-1089-CORE, Issue 4, Generic Requirements for Electronic Equipment Cabinets, Electromagnetic Compatibility and Electrical Safety Generic Criteria for Network Telecommunications Equipment, June 2006.
[GR 1401]	Telcordia GR 1401, LSSGR: Visual Message Waiting Indicator Generic Requirements (FSD 01-02-2000), June 2000, FR-64.
[ID MMUSIC LOOPBACK]	IETF Internet Draft, An Extension to the Session Description Protocol (SDP) for Media Loopback, draft-ietf-mmusic-media-loopback-08.txt, January 2008, work in progress.
[ID SIP ANSWERMODE]	IETF Internet Draft, Requesting Answering Modes for the Session Initiation Protocol (SIP), draft-ietf-sip-answer-mode-06, September 2007, work in progress.

[PKT 24.229]	PacketCable SIP and SDP Stage 3 Specification 3GPP TS 24.229, PKT-SP-24.229-I04-080425, April 25, 2008, Cable Television Laboratories, Inc.
[PKT 33.203]	PacketCable Access Security for IP-Based Services Specification 3GPP TS 33.203, PKT-SP-33.203-I04-080425, April 25, 2008, Cable Television Laboratories, Inc.
[RFC 4330]	IETF RFC 4330, Simple Network Time Protocol version 4 for IPv6, IPv4, and OSI, January, 2006.
[RST E-UE PROV]	PacketCable RST E-UE Provisioning Specification, PKT-SP-RST-EUE-PROV-I01-071106, November 6, 2007, Cable Television Laboratories, Inc.
[RSTF]	PacketCable Residential SIP Telephony Feature Specification, PKT-SP-RSTF-I03-080425, April 25, 2008, Cable Television Laboratories, Inc.
[SEC1.5]	PacketCable 1.5 Security Specification, PKT-SP-SEC1.5-I02-070412, April 12, 2007, Cable Television Laboratories, Inc.
[SR-TSV-002476]	Telcordia Special Report, SR-TSV-002476, CPE Compatibility Considerations for the Voiceband Data Transmission Interface, December 1992.
[TS 23.228]	3GPP TS 23.228 V7.10.0, IP Multimedia Subsystem Stage 2 Specification, December 2007, The 3rd Generation Partnership Project (3GPP).

## 2.2 Informative References

This specification uses the following informative references.

[ANSI T1.508]	ANSI T1.508, Network Performance - Loss Plan for Evolving Digital Networks, 1998.
[ARCH-FRM TR]	PacketCable Architecture Framework Technical Report, PKT-TR-ARCH-FRM-V05-080425, April 25, 2008, Cable Television Laboratories, Inc.
[BR 780-200-020]	Telcordia BR 780-200-020 Tones and Announcements, October 2000.
[GR 517]	Telcordia (Bellcore) GR-517-CORE, Issue 1, LEC Traffic Environment Characteristics, December 1998.
[GR 674]	Telcordia GR-674 LSSGR: Special Information Tones (FSD 20-06-0500), June 2000.
[GR 675]	Telcordia GR-675 LSSGR: Expanded Announcement System (FSD 20-06-0600), June 2000
[Key Smith]	P. Key and D. Smith (editors). 1999. <i>The Internet &amp; The Public Switched Telephone Network – A Troubled Marriage</i> . In <i>Teletraffic Engineering in a Competitive World</i> . Edinberg: Elsevier.
[NFT TR]	PacketCable NAT and Firewall Traversal Technical Report, PKT-TR-NFT-V04-080425, April 25, 2008, Cable Television Laboratories, Inc.
[SR-2275]	Telcordia SR-2275, Telcordia Notes on the Networks, October 2000.
[TIA-912a]	TIA-912a Telecommunication - IP Telephony Equipment - Voice Gateway Transmission Requirements, August 2004.
[TSB-122a]	TIA/EIA/TSB 122a, Telecommunications - IP Telephony Equipment - Voice Router/Gatewayloss and Level Plan Guidelines, March 2001.
[V.25]	ITU-T Rec. V.25 (10/96), Automatic answering equipment and general procedures for automatic calling equipment on the general switched telephone network including procedures for disabling of echo control devices for both manually and automatically established calls.

## 2.3 Reference Acquisition

- Cable Television Laboratories, Inc., 858 Coal Creek Circle, Louisville, CO 80027; Phone +1-303-661-9100; Fax +1-303-661-9199; Internet: <http://www.cablelabs.com/>
- IHS Standards Store, Internet: <http://global.ihs.com/>
- Internet Engineering Task Force (IETF), Internet: <http://www.ietf.org/>  
Note: Internet-Drafts are draft documents valid for a maximum of six months and may be updated, replaced, or obsoleted by other documents at any time. The list of current Internet-Drafts can be accessed at <http://www.ietf.org/ietf/1id-abstracts.txt>.
- ITU-T Recommendations: [www.itu.int/ITU-T/publications/recs.html/](http://www.itu.int/ITU-T/publications/recs.html/)
- Telcordia Technologies, Internet: <http://www.telcordia.com/>
- 3<sup>rd</sup> Generation Partnership Project (3GPP), ETSI Mobile Competence Centre, 650 route des Lucioles, 06921 Sophia-Antipolis Cedex, France, Internet: <http://www.3gpp.org/>.

### 3 TERMS AND DEFINITIONS

This specification uses the following terms:

<b>Configuration Server (Config. Server)</b>	The logical network element responsible for E-DVA provisioning, configuration and management.
<b>Customer Premise Equipment</b>	Usage of CPE within this specification generically refers to the cable modem and E-DVA device that resides at the subscriber home, as well as any customer telephony equipment (telephones, answering machines, fax machines, etc.). Typically, CPE would refer to equipment that is beyond the service provider network interface, such as a telephone or personal computer. However, since the cable modem and E-DVA represent the service provider network interface device at the subscriber home, it is commonly referred to as CPE.
<b>Hybrid Fiber Coax</b>	Access network architecture consisting of fiber optic feeders from the head end to nodes, at which point coaxial cable is used for the final distribution to the subscribers.
<b>Telcordia (Bellcore)</b>	PSTN research/standards organization.
<b>Uninterruptible Power Supply</b>	A power supply including a battery for backup power when AC input power fails.

## 4 ABBREVIATIONS AND ACRONYMS

This specification uses the following abbreviations:

<b>A/D</b>	Analog to Digital converter
<b>CCS</b>	One Hundred Call Seconds
<b>CM</b>	Cable Modem
<b>CMS</b>	Call Management Server
<b>CMTS</b>	Cable Modem Termination System
<b>CPE</b>	Customer Premise Equipment
<b>CSCF</b>	Call State Control Function
<b>D/A</b>	Digital to Analog converter
<b>DOCSIS®</b>	Data-Over-Cable System Interface Specifications
<b>DTMF</b>	Dual Tone Multi Frequency
<b>DVA</b>	Digital Voice Adaptor
<b>eCM</b>	Embedded Cable Modem
<b>eDOCSIS™</b>	Embedded Data-Over-Cable System Interface Specification
<b>E-DVA</b>	Embedded Digital Voice Adaptor, a type of UE
<b>FITL</b>	Fiber In The Loop. A PSTN architecture consisting of a fiber optic access network.
<b>HFC</b>	Hybrid Fiber Coax
<b>IP</b>	Internet Protocol. A network layer protocol
<b>LEC</b>	Local Exchange Carrier
<b>NAT</b>	Network Address Translation
<b>NCS</b>	Network Call Signaling
<b>OSSI</b>	Operations Support System Interface
<b>POTS</b>	Plain Old Telephone Service
<b>PSTN</b>	Public Switched Telephone Network
<b>RST</b>	Residential SIP Telephony
<b>RTCP</b>	Real Time Control Protocol
<b>RTCPXR</b>	Real Time Control Protocol Extended Reports
<b>SDP</b>	Session Description Protocol
<b>SIP</b>	Session Initiation Protocol
<b>STUN</b>	Simple Traversal of User Datagram Protocol (UDP) Through Network Address Translators
<b>UDP</b>	User Datagram Protocol
<b>UE</b>	User Equipment
<b>UPS</b>	Uninterruptible Power Supply

## 5 OVERVIEW

### 5.1 PacketCable Overview

PacketCable is a project conducted by Cable Television Laboratories, Inc. (CableLabs<sup>®</sup>) and its member companies. The PacketCable project is aimed at defining interface specifications that can be used to develop interoperable equipment capable of providing packet-based voice, video, and other high-speed multimedia services over hybrid fiber coax (HFC) cable systems utilizing the Data-Over-Cable Interface Specification [DOCSIS RFIv2.0].

### 5.2 Service Goals

One application of the PacketCable architecture is packet-based voice communications for cable system subscribers. The PacketCable architecture as a whole enables voice communications, video, and data services based on bi-directional transfer of Internet Protocol (IP) traffic between the cable system headend and customer locations, over an all-coaxial or HFC cable network as shown in simplified form in Figure 1.

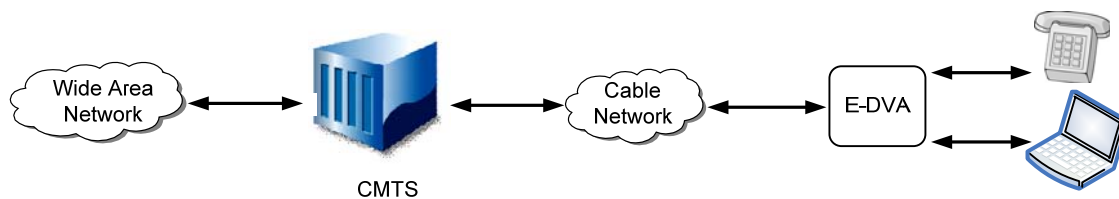

**Figure 1 - Telephony Services Over the Data-Over-Cable System**

The transmission path over the cable system is realized by a cable modem termination system (CMTS) and at each customer location by a cable modem (CM). The E-DVA includes an embedded cable modem and a Residential SIP Telephony (RST) client and analog ports for telephone devices. The E-DVA may include digital ports. The conversion between digital RST signaling and voice to analog telephone interfaces is accomplished within the E-DVA.

### 5.3 PacketCable Reference Architecture

For a description of the PacketCable architecture and Functional Components, please refer to [ARCH-FRM TR].

### 5.4 Embedded Digital Voice Adaptor

A Digital Voice Adaptor (DVA) is a PacketCable client device that contains a subscriber-side interface to the subscriber's CPE (e.g., telephone) and a network-side signaling interface to call control elements in the network (e.g., P-CSCF, S-CSCF, Application servers, etc). A DVA provides codecs and all signaling and encapsulation functions required for media transport and call signaling.

DVAs reside at the customer site and are connected to other PacketCable network elements via the HFC access network (DOCSIS). PacketCable DVAs are required to support the SIP protocol as specified in PacketCable specification [RSTF].

PacketCable only defines support for an embedded DVA (E-DVA). An E-DVA is a single hardware device that incorporates a DOCSIS 1.1 or higher CM as well as a PacketCable DVA component. Figure 2 shows a representative functional diagram of an E-DVA. Additional E-DVA functionality is further defined in [ARCH-FRM TR]. For the purposes of this specification, DVA is interpreted to be identical to E-DVA.

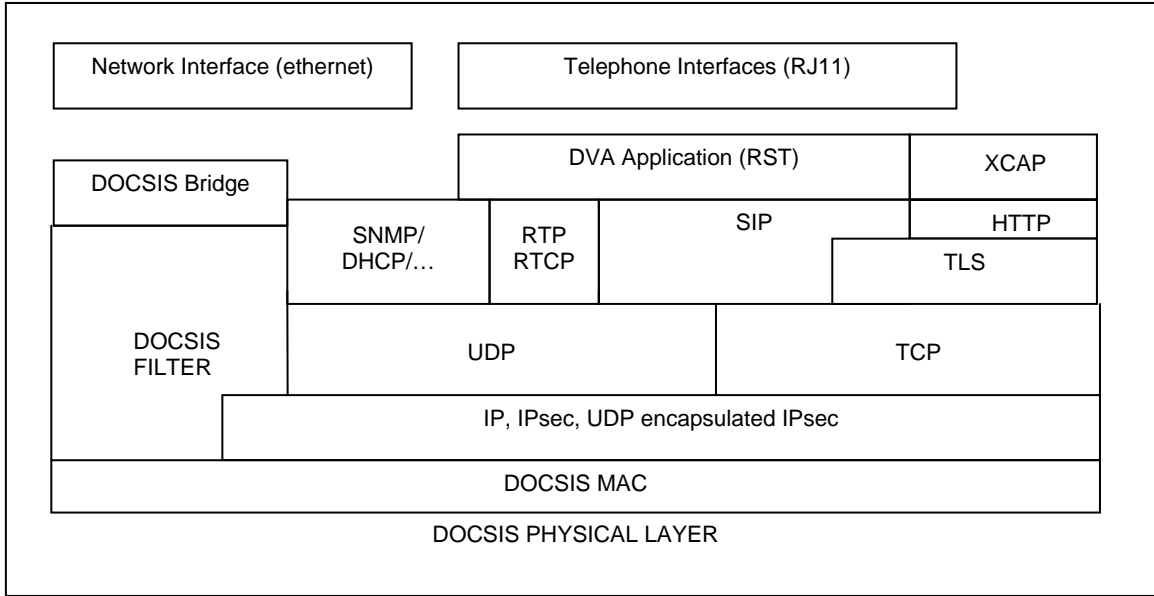

**Figure 2 - E-DVA Protocols**

## 6 E-DVA POWER REQUIREMENTS

This section defines the power requirements of the E-DVA. This includes power consumption and presents associated traffic models recommended for power consumption calculations.

### 6.1 Power Considerations

Local power refers to utilizing the subscriber's home AC utility power as the supply for the E-DVA. A battery backup is utilized to provide telephony services when the utility power fails.

### 6.2 Typical E-DVA Traffic Model

A projected "typical" E-DVA traffic model has been developed based on [GR 517] and [Key Smith] and input from cable operators. With this qualification, this model may be used to calculate long term average power.

**Table 1 - E-DVA Traffic Model**

Line Number	E-DVA Line 1	E-DVA Line 2	E-DVA Line 3	E-DVA Line 4	Cable Modem Data
Assumed Use	Voice	Modem/Voice	Voice/Fax	Voice	High Speed Data
CCS (100 call seconds)	4	4	2	2	4
Line Penetration (Normalized by Penetration)	100%	80%	50%	25%	25%
Average Ringing Period	14 sec	14 sec	14 sec	14 sec	n/a
Average call length					
E-DVA w/o Data Service	5 min	26 min	5 min	5 min	n/a
E-DVA with Data Service	5 min	5 min	5 min	5 min	n/a
Average Data Rate to Subscriber	n/a	n/a	n/a	n/a	100kb/s
Average Data Rate From Subscriber	n/a	n/a	n/a	n/a	10kb/s

The average cable modem data rates shown in Table 1 assume that when a user is active on the system (i.e., 4CCS), the user is interpreting or typing information during 90% of the active session, and no significant data is flowing through the data interface. Data interface rates of 1Mb/s to the subscriber and 100kb/s from the subscriber are assumed during the remaining 10% of the session. The averages are assumed to be long term and are considered over the entire domain of a power node (i.e., 100's of E-DVAs).

### 6.3 Service Requirements Under AC Fail Conditions

The E-DVA MUST remain operational during the switch between AC outage to battery backup. The E-DVA MUST also maintain provisioned services (operational means capable of originating calls, ringing, and terminating calls, if provisioned as in-service). When in battery mode, services will be offered as configured by the operator. This configuration may be different from the services when provided with AC power. The E-DVA MUST maintain established telephony calls across the switch over between AC power and battery back up. Since data traffic is not required for PacketCable service, the E-DVA data service MAY be de-activated immediately under local AC power fail conditions.

### 6.4 Local Powering with Battery Backup

Local powering is accomplished utilizing a UPS that converts household 120V AC power to DC power for the E-DVA. The UPS also provides battery backup to bridge E-DVA operation through typical local power outages. In addition, telemetry signals provide remote monitoring capability for local AC power and battery conditions. The indoor climate controlled environment is typically desired for battery placement to maximize battery life. E-DVAs MAY include an embedded UPS or utilize an external UPS.

## 7 E-DVA ANALOG PORT REQUIREMENTS

The E-DVA analog port represents an interface between the PacketCable/DOCSIS/IP (Internet protocol) network and devices designed to function when connected to the PSTN using standard PSTN interfaces. The subscriber side of this interface is an analog interface consistent with the PSTN, and the network side of this interface is a digital interface to the IP-based PacketCable network, which rides on top of the DOCSIS transport. It is expected that many operators will choose to use the PacketCable architecture to offer service to customers in residential dwellings. In such applications, the E-DVA will reside at the subscriber premises, typically as an interior unit with battery backup. Finally, because the network side of the port interface is digital, and the device resides close to the subscriber, the analog subscriber side of the port interface will only be required to support relatively short metallic (copper twisted pair) drops (i.e., 500 feet).

This interface is similar to the Telcordia GR-909 POTS interface requirements for FITL (fiber in the loop). Therefore, the port requirements are based on GR-909-CORE [GR 909]. For basic PacketCable service, the requirements can be divided into four categories:

- Loop Start Signaling (section 4.1 of [GR 909])
- General Supervision (section 4.4 of [GR 909])
- General Ringing (section 4.5 of [GR 909])
- Voice Grade Analog Transmission (section 5 of [GR 909])

The E-DVA analog 2-wire interface requirements are listed in the following sections.

For the purpose of this section, the subscriber twisted pair copper wiring (typically the wiring inside the subscriber's premises) that is connected to the E-DVA analog port will be referred to as the "loop." Note that this usage is different than the way these terms may be used in the context of the PSTN, in which the "loop" is defined as the transmission path between a telephone company central office and a customer's premises. The "loop" referred to in this section, in PSTN terms, would typically be referred to as "premises wire" or "inside wire." References here to "loops" and "transmission paths" should not be confused with links from customer premises to either a telephone company office or to a cable operator's headend.

### 7.1 Loop Start Signaling

#### 7.1.1 DC Supervisory Range

The DC supervisory range MUST meet:  $R_{DC} \geq 450$  ohms.  $R_{DC}$  is the DC supervisory range. The actual value of  $R_{DC}$  depends on the resistance of the loop wire from the E-DVA (the subscriber's inside wiring). That is,  $R_{DC} = 430$  Ohms +  $R_{loop}$ . Note that this accommodates a drop of 500 feet of AWG 22-gauge wire at 65 degrees Celsius.

Reference: section 4.1.1 of [GR 909].

#### 7.1.2 Idle State Voltage

The idle state is when the loop is open or on-hook. In this state, the idle voltage MUST:

- be  $42.75V_{dc} \leq V_{IDLE} \leq 80$  V DC; and
- have Class A2 continuous source electrical safety from section 14.6 of [GR 499] satisfied.

In this state, the idle voltage SHOULD:

- have a Ring that is negative with respect to tip
- have Ring-to-ground and tip-to-ground voltages that are  $< 0$

Reference: section 4.1.2 of [GR 909].

### 7.1.3 Loop Closure Detection

Loop closure is off-hook. Detection of loop closure in the E-DVA MUST meet:

- Resistance  $\leq R_{DC}$  between tip and ring is loop closure;
- Resistance  $\geq 10k$  ohms between tip and ring is not loop closure.

Reference: section 4.1.4 of [GR 909].

### 7.1.4 Loop Open Detection

Loop open is on-hook. Detection of loop open in the E-DVA MUST meet:

- Resistance  $\geq 10k$  ohms is loop open;
- Resistance  $\leq R_{DC} + 380$  ohms is not loop open;

The E-DVA MUST be able to distinguish between a hit, dial pulse, flash, or disconnect.

Reference: section 4.1.5 of [GR 909].

### 7.1.5 Off-Hook Delay

The E-DVA MUST meet the timing requirements R11-33 of [GR 506] for detecting a subscriber origination request (off-hook).

The E-DVA MUST be able to generate the local dial tone within 50 msec of detecting a subscriber origination request (off-hook).

The E-DVA MUST be capable of establishing a 2-way voice signal transmission capability on the loop established within 50 msec of detecting the subscriber termination request (off-hook).

Reference: section 4.1.7 of [GR 909].

### 7.1.6 Flash Hook Delay

The E-DVA MUST meet the timing requirements in section 12 of [GR 506] for detecting a flash signal and a subscriber termination request (on-hook).

The E-DVA MUST be able to signal to the network about a flash signal within 50 msec of detecting such an event.

### 7.1.7 On-Hook Delay

The E-DVA MUST meet the timing requirement in section 12 of [GR 506] for detecting an on-hook signal and a subscriber termination request (on-hook).

The E-DVA MUST be able to signal to the network about an on-hook signal or a subscriber termination request within 50 msec of detecting such an event.

### 7.1.8 Ringsplash

When a feature requires one 500 msec ringsplash, the E-DVA MUST apply one 500 +/- 50 msec ring burst to the line.

Reference: section 4.1.9 of [GR 909].

### 7.1.9 Distinctive Alerting

Defined ring cadences MUST be applied to the drop within +/-50 msec resolution. The E-DVA MUST be able to apply any of the distinctive alerting patterns described in the PacketCable Residential SIP Telephony Feature Specification [RSTF] on the line when signaled by the PacketCable network.

Reference: section 4.1.10 of [GR 909].

### 7.1.10 Transmission Path

The E-DVA MUST support part-time on-hook transmission capabilities: part-time = within 400 msec after a ringsplash. On-hook transmission provides the capability of transmitting a voiceband signal in both directions on the loop when the loop is open (on-hook).

Reference: section 4.1.15 of [GR 909].

## 7.2 General Supervision

### 7.2.1 Off-Hook Loop Current

The E-DVA MUST provide at least 20 mA of loop current in the off-hook state. Loop voltage is such that the ring conductor is negative with respect to the tip conductor.

Reference: section 4.2.1 of [GR 909].

### 7.2.2 Immunity to Line Crosses

Shorts between tip-to-tip, tip-to-ring, or ring-to-ring involving two or more lines MUST NOT damage the E-DVA. Shorts between tip-to-ground or ring-to-ground involving one or more lines MUST NOT damage the E-DVA.

Reference: section 4.4.3 of [GR 909].

### 7.2.3 System Generated Open Intervals

When in the loop closure state (off-hook), interruptions to loop current feed on the E-DVA MUST NOT exceed 100 msec.

Reference: section 4.4.5 of [GR 909].

Network Disconnect (or Loop Current Feed Open) is signaled by the network side of a loop start interface when the distant end releases while the CPE is offhook. Typically this signal is used to notify electronic equipment, such as answering machines, that the caller has hung up. When provisioned to do so via the NetDisc data element, the E-DVA MUST remove DC bias for 1 second +/- 400 milliseconds when a call has been cleared by the network.

**Table 2 - E-DVA Network Disconnect Signaling Event**

Data	Type	Persistence	Scope	Stored by	Written by	Read by	Config. Server Requirement
NetDisc	Integer (mSec) Range: 0 to 2000 Increments: 100 Default: 1000	Non-volatile	Per Line	Config. Server	Config. Server	Config. Server, E-DVA	Mandatory

NetDisc value of 0 indicates that the E-DVA MUST NOT remove DC bias when a call disconnects. The default value of NetDisc should be 1000 milliseconds. The default NetDisc for Answer Signal should be "off."

### 7.2.4 Open Switching Interval Distortion

The following are the Open Switching Interval Distortion requirements. When in the loop closure state and providing loop current feed, E-DVA loop current feed open commands of duration, T MUST have resolution +/-25 msec for  $50 \leq T \leq 1000$  msec. When in the above state, the E-DVA MUST continue to maintain loop closure with no interruptions >1 msec.

- Loop current feed open MUST NOT exceed 5 sec in duration.
- Loop current feed is an interruption of the loop current sourced on the drop.

Reference [GR 303] specifies that these closure requirements MUST be satisfied for both on-hook and off-hook.

Reference: section 4.4.6 of [GR 909].

### 7.2.5 Answer Supervision Signal (AnsSup)

Answer Supervision (also called battery reversal, reverse DC bias, or Reverse Loop Current Feed) is signaled when the distant end answers a call originated by the CPE. Typically this signal is used to notify electronic equipment such as PBXs which have a local billing system that a call has been answered. When provisioned to do so via the AnsSup data element, the E-DVA MAY reverse DC bias when a call has been answered.

**Table 3 - E-DVA Answer Supervision Event**

Data	Type	Persistence	Scope	Stored by	Written by	Read by	Config. Server Requirement
AnsSup	Boolean Default: FALSE	Non-volatile	Per Line	Config. Server	Config. Server	Config. Server, E-DVA	Mandatory

The default AnsSup value for Answer Signal should be “FALSE” ( or "OFF").

### 7.2.6 Dial Pulsing

Dial pulses MUST be collected at the E-DVA. The digits are gathered according to the digit map and all digits are sent in a single message. The E-DVA MUST support 8-12 pps with a 58-64% break.

Reference: section 4.4.9 of [GR 909].

### 7.2.7 DTMF Signaling

The E-DVA MUST support the use of DTMF for both dialed digits and for the relay of digits as part of an established session. When dialing the DTMF, signaling MUST be collected at the E-DVA. The digits are gathered according to the digit map and all digits are sent in a single message.

The E-DVA MUST NOT amplitude overload at the maximum expected DTMF signal level per [ANSI T1.401]. ([ANSI T1.401] describes the maximum DTMF signal level.) Amplitude overload is any output frequency between 0 – 12 kHz at a power level greater than -28 dBm0, when the input frequency is between 600 – 1500 Hz at a power level equal to the maximum expected DTMF signal level.

The E-DVA MUST apply DTMFs tone to the audio path, or the E-DVA MUST generate DTMF relay per [CODEC-MEDIA] as dictated from the negotiated SDP associate with the session.

The E-DVA MUST offer DTMF relay within SDP upon session origination as provisioned in the DTMF RELAY feature data element.

**Table 4 - DTMF Relay Offer**

Data	Type	Persistence	Scope	Stored by	Written by	Read by	Config. Server Requirement
DTMF RELAY	Boolean Default: TRUE	Non-volatile	Per E-DVA	Config. Server	Config. Server	Config. Server, E-DVA	Mandatory

The default value of DTMF\_RELAY = “TRUE” instructs the E-DVA to offer DTMF relay within SDP upon session origination.

### 7.2.8 DIALTONE REMOVAL

The E-DVA MUST remove dialtone within 250 msec of detecting the first dialed digit.

Subsequent digit analysis in accordance to the digit map may result in re-application of dialtone by the E-DVA. The requirement for dialtone removal also applies to such a re-application of the dialtone.

Note, however, that the act of re-applying the dialtone is a digit map action and independent of this requirement.

## 7.3 General Ringing

### 7.3.1 Alerting Signals

The E-DVA MUST support unbalanced or balanced ringing. The applied cadence MUST be within +/-50 msec of the defined cadence. Nominal cadence has a 6-sec period with 1.7 to 2.1 sec ringing and 3.1 to 5.5 sec of silence.

For Unbalanced Ringing, the alerting cadence is applied to ring with tip grounded. The DC component during ringing is such that the ring conductor is negative with respect to tip.

For Balanced Ringing, the alerting cadence is applied to both tip and ring, typically 180° out of phase, with or without a DC component.

Reference: section 4.5.2 of [GR 909]. Modified for PacketCable for optional balanced ringing.

### 7.3.2 Ringing Delay

Ringing MUST be applied within 200 msec of the E-DVA receiving SIP INVITE with SDP. The cadence MUST be used as per configuration entered at any point (i.e., the cadence may start with the silent period).

Reference: section 4.5.3 of [GR 909].

### 7.3.3 Ringing Source

The E-DVA Ringing Source MUST meet the duration-limited source safety requirements of [GR 1089].

The E-DVA ringing frequency MUST be 20+/-1 Hz.

The E-DVA ringing source DC component (offset) MUST be  $\leq 75$  Vdc.

The E-DVA Ringing Source MUST meet  $1.2 \leq \text{peak-to-rms voltage ratio} \leq 1.6$ .

The E-DVA ringing source bridged C-weighted noise MUST be  $\leq 90$  dBnC, when referenced to 900 ohms during ringing (i.e., the 20 Hz component  $< 0$  dBm), and the analog voice band lead conducted emissions criteria of [GR 1089].

Reference: section 4.5.4 of [GR 909].

### 7.3.4 Ringing Capability

The minimum ringing voltage of the E-DVA MUST meet 40 Vrms across a 5 REN load on a drop with resistance  $\leq R_{DC} - 400$  ohms.

Reference: section 4.5.5 of [GR 909].

### 7.3.5 Ringing Capacity

The E-DVA MUST be capable of supporting 5 REN per analog line as described in [GR 909].

Reference: section 4.5 of [GR 909].

### 7.3.6 Ring Trip

The E-DVA Ringing MUST be removed within 200 msec of detecting loop closure.

Reference: section 4.5.7 of [GR 909].

### 7.3.7 Ring Trip Detect Delay

The E-DVA MUST be able to detect a ring trip within 300 msec.

Reference: section 4.5.8 of [GR 909].

### 7.3.8 Ring Trip Immunity

E-DVA Ringing MUST NOT be tripped when a termination of 10k ohm in parallel with 5 REN load is applied between tip and ring.

E-DVA Ringing MUST NOT be tripped when a termination of 200 ohm is applied between tip and ring for  $\leq 12$  msec.

Reference: section 4.5.9 of [GR 909].

## 7.4 Voice Grade Analog Transmission

The PacketCable system utilizes digital transmission of voice signals to and from the DVA. The DVA converts between the digital voice signal on the IP network and the analog voice signal on the tip and ring loop. System impairments in the digital network, such as packet loss, can affect the voice signal but are outside the control of the DVA. Therefore, this section defines the analog voiceband requirements of the DVA and assumes an error-free digital network.

These requirements are derived from the PSTN, which, in some cases, utilizes analog transmission from a headend central office switch to a customer. Typically, the reference point by which these requirements are measured is the middle of the switch (digital to analog). This reference point is referred to as the 0 Transmission Level Point (TLP) and could be thought of as any point in the digital portion of the network.

Note that these are not end-to-end analog requirements since they apply to a single digital to analog conversion point (a typical voice call will be analog at each end with a digital network connecting the two ends). The 0 TLP of the PacketCable system is any point in the digital IP network. The digital IP network, for voice signal transmission purposes, extends all the way to the DVA where the digital to analog conversion occurs. These requirements only apply to the G.711 audio codec as specified in [CODEC-MEDIA]. Transmission requirements for the other compression algorithms specified in [CODEC-MEDIA] are not yet defined.

In general, all these requirements MUST be satisfied for both on-hook and off-hook parameters.

### 7.4.1 Input Impedance

The E-DVA input impedance MUST meet:

- 600 ohms nominal;
- ERL (echo return loss)  $> 26$  dB (29 dB objective);
- SRL (singing return loss)  $> 21$  dB (24 dB objective).

Reference: section 5.3.3 of [GR 909].

### 7.4.2 Hybrid Balance

The E-DVA Hybrid Balance MUST meet, where  $L_{T1}$  is transmit loss and  $L_{R1}$  is receive loss at 1004 Hz:

- ERL  $> 21$  dB (26 dB objective);
- SRL  $> 16$  dB (21 dB objective);
- ERL =  $15 + L_{T1} + L_{R1}$ ;
- SRL =  $10 + L_{T1} + L_{R1}$ .

Reference: section 5.3.4 of [GR 909].

### 7.4.3 Longitudinal Balance

The E-DVA Longitudinal Balance MUST meet:

- 200 Hz: min  $> 45$  dB, ave  $> 50$  dB (ave  $> 61$  dB objective);
- 500 Hz: min  $> 45$  dB, ave  $> 50$  dB (ave  $> 58$  dB objective);

- 1000 Hz: min > 45 dB, ave > 50 dB (ave > 52 dB objective);
- 3000 Hz: min > 40 dB, ave > 45 dB.

Reference: section 5.3.5 of [GR 909].

#### 7.4.4 E-DVA Loss

The E-DVA loss plan is part of a network loss plan, which considers not only the analog loss between end points, but also the end to end delay, the loop back delay, noise and echo cancellation. Guidance in setting the DVA loss can be found in [ANSI T1.508], [TSB-122a], and [TIA-912a] Table 1, which defines various termination points across a network.

Additional consideration must be taken due to the short analog loop architecture with the DVA. In this configuration there is a potential risk of G.711 codec overload with DTMF signaling. In this configuration it is recommended that an additional loss in each direction (D/A and A/D) be configured in the DVA.

Additionally, variations in network deployments result in variations in the end to end and loop back delays. These delay variations must also be considered in setting the loss plan values.

Due to these considerations, for each telephony line, the DVA MUST support two provisioned loss parameters, one for the D/A direction (towards the subscriber) and one for A/D direction (from the subscriber) direction.

The E-DVA MUST support a provisioning range of 0 dB to 12 dB of loss in 1 dB increments.

**Table 5 - E-DVA Provisioned Loss Plan**

Data	Type	Persistence	Scope	Stored by	Written by	Read by	Config. Server Requirement
D/A Loss	Integer (dB) Range: 0 to 12 Increments: 1 Default: 6	Non-volatile	Per Line	Config. Server	Config. Server	Config. Server, E-DVA	Mandatory
A/D Loss	Integer (dB) Range: 0 to 12 Increments: 1 Default: 6	Non-volatile	Per Line	Config. Server	Config. Server	Config. Server, E-DVA	Mandatory

**Note:** In loss planning, positive numbers represent loss and negative numbers represent gain.

#### 7.4.5 E-DVA Loss Tolerance

E-DVA Loss Tolerance MUST be within +/-0.5 dB of the provisioned loss.

Reference: [TIA-912a] clause 6.5.4.1.

#### 7.4.6 Frequency Response

The E-DVA Off-hook transmission loss between 400-2800 Hz MUST be within -0.5 to +1 dB of the loss at 1004 Hz using a 0 dBm0 signal.

The E-DVA On-hook transmission loss between 400-2800 Hz MUST be within -1 to +2 dB of the loss at 1004 Hz using a 0 dBm0 signal. (+ means more loss, - means less loss).

Reference: section 6.1.9 of [GR 57].

#### 7.4.7 60 Hz Loss

The E-DVA transmission path loss at 60 Hz MUST be at least 20 dB greater than the off-hook transmission path loss at 1004 Hz. The intention is to limit the encoding of 60 Hz induction in the A/D direction.

Reference: section 6.1.10 of [GR 57].

#### 7.4.8 Amplitude Tracking

The E-DVA deviation of a 1004 Hz off-hook transmission path loss relative to the loss of a 0 dBm0 input signal MUST meet:

- -37 to +3-dBm0 input: +/-0.5 dB max (+/-0.25 dB ave);
- -50 to -37-dBm0 input: +/-1.0 dB max (+/-0.5 dB ave);
- -55 to -50-dBm0 input: +/-3.0 dB max (+/-1.5 dB ave).

The E-DVA deviation of a 1004 Hz on-hook transmission path loss relative to the loss of a 0 dBm0 input signal MUST meet:

- -37 to 0 dBm0: +/-0.5 dB max.

Reference: section 6.1.11 of [GR 57].

#### 7.4.9 Overload Compression

The increase in the E-DVA off-hook transmission path loss at 1004 Hz relative to the loss of a 0 dBm0 input signal MUST meeting the following:

- +3 dBm0 input: <= 0.5 dB increased loss;
- +6 dBm0 input: <= 1.8 dB increased loss;
- +9 dBm0 input: <= 4.5 dB increased loss.

This is to ensure the receiver off-hook signal can be transmitted.

Reference: section 6.1.12 of [GR 57].

#### 7.4.10 Idle Channel Noise

The idle channel noise MUST NOT exceed 20 dBmC at the output of the E-DVA (18 dBmC objective).

Reference: section 6.1.13 of [GR 57].

#### 7.4.11 Signal to Distortion

The E-DVA ratio of the output signal to output C-notched noise with a 1004 Hz input signal while providing an onhook and off-hook transmission path MUST meet:

- 0 to -30-dBm0 input: >33-dB ratio;
- -30 to -40-dBm0 input: >27-dB ratio;
- -40 to -45-dBm0 input: >22-dB ratio.

Reference: section 5.3.15 of [GR 909] and section 6.1.14 of [GR 57].

#### 7.4.12 Impulse Noise

The E-DVA impulse noise MUST meet:

- <=15 impulses in 15 minutes with no holding tone applied at a threshold of 47 dBmC0;
- <=15 impulses in 15 minutes with a -13 dBm0 tone at 1004 Hz at a threshold of 65 dBmC0.

These SHOULD be met for both the on-hook and off-hook transmission path. For a line under test, other lines on the E-DVA SHOULD be active (off-hook, dialing, ringing, etc.).

Reference: section 5.3.16 of [GR 909] and section 6.1.15 of [GR 57].

### 7.4.13 Intermodulation Distortion

The E-DVA intermodulation distortion MUST meet:

- $R_2 > 43$  dB using a  $-13$  dBm0 input signal;
- $R_3 > 44$  dB using a  $-13$  dBm0 input signal.

$R_2$  and  $R_3$  are the 2nd and 3rd order intermodulation products measured using the IEEE 743-1984 4-tone method.

Reference: section 6.1.16 of [GR 57].

### 7.4.14 Single Frequency Distortion

The E-DVA single frequency distortion MUST meet:

- Using a 0 dBm0 input signal between 0-12 kHz, the output between 0-12 kHz  $< -28$  dBm0;
- Using a 0 dBm0 input signal between 1004-1020 Hz, the output between 0-4 kHz  $< -40$  dBm0.

Reference: section 6.1.17 of [GR 57].

### 7.4.15 Generated Tones

The E-DVA generated tones MUST meet:

- $< -50$  dBm0 between 0-16 kHz

Reference: section 5.3.20 of [GR 909].

### 7.4.16 Peak-to-Average Ratio

The E-DVA peak-to-average ratio of transmission paths MUST meet:

- $P/AR > 90$  with a  $-13$  dBm0 input level. On-hook and off-hook transmission paths.

Reference: section 6.1.19 of [GR 57].

### 7.4.17 Channel Crosstalk

With a 0-dBm0 signal between 200-3400 Hz applied to a line, other lines on the E-DVA MUST meet  $< -65$  dBm0 C message weighted output between 200-3400 Hz.

Reference: section 5.3.22 of [GR 909] and section 6.1.20 of [GR 57].

## 7.5 Out of Service Requirements

The PacketCable specification [RSTF] section, *In-Service and out-of-service states*, defines the conditions where the E-DVA determines a network availability state and uses one of several analog line supervisory tones (dial tone, re-order tone, etc.) to indicate to the end user or device the current network state when a connection is attempted (E-DVA off hook state).

In addition to supervisory tones, some end user devices (security systems) also determine network connection likelihood by detecting the analog telephony DCbias at the E-DVA telephony termination point. This technique continuously monitors the DCbias and the loss of DCbias is interpreted by the security system as an alarm state. This type of alarm service, therefore, also requires mechanisms to manage the analog telephony DCbias signal both in the E-DVA on hook and off hook state to indicate the current network availability state.

The goal must be to provide E-DVA telephony termination point conditions (DCbias and supervisory tone signals) consistent with historical PSTN services while also providing a method where planned or scheduled Network or E-DVA operations (network maintenance, software downloads, reboots) do not cause unwanted or inappropriate security alarms.

Due to the fact that end user alarms are subject to the E-DVA and network availability states, including short term, planned outages, it is required to allow the service provider to provision various parameters related to network availability state including planned outages, signaling types, timer durations etc. to properly signal the current system state to the end user and the end user devices.

### 7.5.1 E-DVA On Hook State

In this E-DVA state, the DCbias is the signaling method to indicate the Network/E-DVA in/out-of-service state. The E-DVA MUST support provisioning of the On Hook state DCbias. The Operator is able to provision to enable planned, scheduled service times to not be signaled as an out-of-service state pending a maximum duration element.

DCbiasSig element enables/disables the DCbias management per provisioned values on a per telephony port basis.

The E-DVA MUST perform DCbias per DCbias provisioned elements with a DCbiasSign element value of 0.

A value of 1 indicates that the DCbias is not controlled by the provisioned elements.

DCbiasMax element sets the maximum period of time that a DCbias is to be maintained following an E-DVA reboot requiring a in-service State re-establishment per [RSTF]. The E-DVA MUST maintain DCbias following an E-DVA reboot requiring an in-service State re-establishment per [RSTF] for the time period indicated in the DCbiasMax element.

Upon any reset or reboot, the E-DVA SHOULD NOT remove DCbias from the telephony termination point for longer than the Network Disconnect Interval (typically 1 second +/- 400 milliseconds). The E-DVA MUST NOT remove DCbias for more than 5 seconds, as long as the operational AC or battery power supply to the E-DVA is maintained across such an initialization event. An E-DVA then MUST comply with the DCbiasMax element. Note that not every security system will accept a 5-second DCbias removal time without alarming. Therefore, it is important to minimize any outage time under any condition.

If the Network/E-DVA fails to re-establish the in-service state per [RSTF] during the DCbiasMax duration, the E-DVA MUST remove the DCbias from the telephony port when the DCbiasMax duration expires.

If the Network/E-DVA succeeds to re-establish the in-service state per [RSTF] during the DCbiasMax duration, the E-DVA MUST cancel the DCbiasMax resulting in the DCbias being maintained on the telephony port in support of normal telephony signaling requirements.

DCbiasHold element sets the period of time that a DCbias is maintained following an out-of-service state per [RSTF]. The E-DVA MUST maintain DCbias following an out-of-service state per [RSTF] for the period of time indicated in the DCbiasHold date element.

If the DCbiasHold duration expires, the E-DVA MUST remove DCbias from the telephony port.

If the Network/E-DVA succeeds to re-establish the in-service state per [RSTF] during the DCbiasHold duration, the E-DVA MUST be cancel DCbiasHold resulting in the DCbias being maintained on the telephony port in support of normal telephony signaling requirements.

DCbiasEnable element sets a delay time period prior to reapplying DCbias on the E-DVA telephony port following the re-establishment of the in-service state per [RSTF] and following a DCbias removal. This avoids "race" conditions between the Network/E-DVA transitions from inappropriately signaling to the end user security system. The E-DVA MUST reapply DCbias on the telephony port following the re-establishment of the in-service state per [RSTF] and following a DCbias removal after the delay timer period indicated by the DCbiasEnable element.

**Table 6 - Network/E-DVA On Hook In/Out of Service**

Data	Type	Persistence	Scope	Stored by	Written by	Read by	Config. Server Requirement
DCbiasSig	Boolean Default: FALSE	Non-volatile	Per Line	Config. Server	Config. Server	Config. Server, E-DVA	Mandatory
DCbiasMax	Integer (seconds) Range: 0 to 2400 Default: 1200	Non-volatile	Per Line	Config. Server	Config. Server	Config. Server, E-DVA	Mandatory
DCbiasHold	Integer (seconds) Range: 0 to 1200 Default: 600	Non-volatile	Per Line	Config. Server	Config. Server	Config. Server, E-DVA	Mandatory
DCbiasEnable	Integer (seconds) Range: 0 to 60 Default: 5	Non-volatile	Per Line	Config. Server	Config. Server	Config. Server, E-DVA	Mandatory

**Considerations:**

1. During call processing states, the E-DVA MUST NOT remove DCbias from the telephony termination point for longer than the Network Disconnect Interval (typically 1 second +/- 400 milliseconds).
2. The echo canceller in the E-DVA MUST be able to pass test 14 in [G 168] when a V-series low-speed (< 9,6 kbit/sec) modem is used which does not send a 2100 Hz disable tone with phase reversals. This is not unique to E-DVA to home security systems but is reflective of compliance to ITU-T V.25 requirements for in band analog modem signaling.

**7.5.2 E-DVA Off Hook State**

In this E-DVA state, In-Service and out-of-service states MUST be supported as per [RSTF].

Some E-DVA telephony termination ports may be used by security systems which may require the removal of DCbias to signal an alarm state. The enabling of the DCbiasSig element which enables/disables the DCbias management per provisioned values on a per telephony port basis will provide selective management of the DCbias signaling on a per telephony port basis.

All sub-elements of DCbiasSig MUST be supported if DCbiasSig is enabled.

**7.5.3 DTMF Signaling**

Some Home Alarm systems use proprietary DTMF signaling protocols. These protocols assume DTMF decoders and encoders meet Telcordia or ETSI standards. This places specific requirements on the E-DVA with respect to DTMF relay. DTMF telephone-events MUST be fully played out by an egress gateway according to the duration specified in the event subject to an optional minimum play-out duration. The DTMF events MUST be provisioned on the E-DVA endpoint per the [CODEC-MEDIA] to reflect Telcordia [GR 506] section 15.4.8, DTMF Signal Duration R15-52. DTMF signals generated by an E-DVA MUST have a signal duration of 50 milliseconds.

**7.5.4 Expanded Network Service Outages**

While services have been offered to provide operators methods to minimize Home Security System alarms during scheduled or known periods of network un-availability, situations may still exist where it is desirable for the operator to further expand the DCbias durations beyond the provisioned values. Under these cases, the Operator may remotely direct the E-DVA to expand the current DCbias duration times for a single event so as to provide short term maintenance flexibility while still maintaining Home Security System requirements.

**7.6 Message Waiting Indicator**

The E-DVA MUST follow the general requirements on the Message Waiting Indicator (MWI) given in [RSTF].

Upon receiving the NOTIFY message from the MWI Application Server, the E-DVA MUST present the corresponding MWI to the user's CPE device via a MWI tone, a MWI voice announcement, a MWI FSK signal, or a MWI DTMF signal, according to the provisioned UE MWI Tone Indication, UE MWI Voice Announcement Indication, UE MWI FSK Indication and UE MWI DTMF Indication data parameters in Table 7. The following are additional requirements on MWI:

- The MWI FSK or DTMF signal is presented to the user's CPE device through the analog port on the E-DVA when the CPE device is on-hook. In presenting these signals, the E-DVA MUST follow the corresponding requirements in [GR 30] section 2.3.2, [SR-TSV-002476], [GR 1401], [GR 506], [EN 300 659-1] clause 6.2, and [EN 300 659-3] clause 5.2.2.
- The MWI tone or voice announcement MUST be presented to the user's CPE device through the analog port on the E-DVA when the CPE device goes off-hook.
- If the MWI arrives while the line is busy, the E-DVA MUST delay the presentation until the line goes back to the idle state.

The E-DVA can have built-in capabilities to present the MWI signals in a visual or audible format directly to the user. Such local capabilities are vendor-specific and are outside the scope of this specification.

**Table 7 - MWI Signal Types**

<b>Data</b>	<b>Type</b>	<b>Persistence</b>	<b>Scope</b>	<b>Stored by</b>	<b>Written by</b>	<b>Read by</b>	<b>Config. Server Requirement</b>
UE MWI Tone Indication	Boolean	Non-volatile	Per public user ID	Config. Server	Config. Server	E-DVA	Mandatory
UE MWI Voice Announcement Indication	Boolean	Non-volatile	Per public user ID	Config. Server	Config. Server	E-DVA	Mandatory
UE MWI FSK Indication	Boolean	Non-volatile	Per public user ID	Config. Server	Config. Server	E-DVA	Mandatory
UE MWI DTMF Indication	Boolean	Non-volatile	Per public user ID	Config. Server	Config. Server	E-DVA	Mandatory

## 8 CLIENT REQUIREMENTS

### 8.1 Provisioning

The E-DVA MUST comply with the E-DVA provisioning requirements as specified in [RST E-UE PROV].

### 8.2 Security

The security considerations for the E-DVA are based on those specified in [PKT 33.203], [TS 23.228], [PKT 24.229], and [NFT TR]. The requirements specific to the E-DVA are provided below.

#### 8.2.1 Authentication

As part of the SIP registration for each provisioned line, the E-DVA MUST support SIP-Digest-based authentication with the PacketCable core network as detailed in [PKT 33.203] and [PKT 24.229], using the corresponding Private User Identity/Public User Identity pair and the User ID/Password pair obtained as part of the Secure Provisioning Flow or from the Configuration Server during the bootstrapping process. The registration also allows the E-DVA to establish any necessary security associations for the SIP signaling security with the P-CSCF, as specified in [PKT 33.203].

The E-DVA MAY support any other authentication procedure described in [PKT 33.203].

#### 8.2.2 Signaling Security

The E-DVA MUST support TLS for the SIP-signaling security.

The E-DVA MAY support other signaling-security protocols specified in [PKT 33.203].

For both authentication and signaling security the E-DVA MUST use the X.509v3 certificate profile as follows.

E-DVA certificates MUST follow the MTA Device certificate profile specified in [SEC1.5]. Existing PacketCable 1.0 and 1.5 MTA certificates are being reused for PacketCable Release 2.0. E-DVA certificates MUST be issued by MTA Manufacturer Certificate Authorities as specified in [SEC1.5].

In order to perform authentication for secure configuration, the E-DVA MUST possess the CableLabs Service Provider Root CA certificate. This certificate is installed into each E-DVA at the time of manufacture or with a secure software download as specified in [SEC1.5] and MUST NOT be updated by the provisioning server.

### 8.3 NAT/Firewall Traversal

Even though there is no NAT/Firewall between the E-DVA and the CMTS, there may be a network-based NAT/Firewall behind the CMTS.

The NAT/Firewall traversal requirements described in [TS 23.228], [PKT 24.229], and [NFT TR] SHOULD be supported by the E-DVA.

## 8.4 Codecs

G.711  $\mu$ -law, G.711 A-law [G 711], T.38, V.152, and DTMF Relay **MUST** be supported by the E-DVA per the [CODEC-MEDIA] specification. Both  $\mu$ -law and A-law **MUST** be offered at session establishment if G.711 is offered. The packet period of a G.711 payload is configured as shown in the table below. The offering of T.38, V.152, and DTMF Relay at session establishment is determined based on the setting of their respective data element as described below. Table 8 provides a summary of the E-DVA data elements related to CODEC configuration.

**Table 8 - E-DVA CODEC Provisioning**

Data	Type	Persistence	Scope	Stored by	Written by	Read by	Config. Server Requirement
G711 Packet	Integer (msec) Range: 10-30 Increments: 10 Default: 20	Non-volatile	Per E-DVA	Config. Server	Config. Server	Config. Server, E-DVA	Mandatory
T38	Boolean Default: TRUE (or ON)	Non-volatile	Per E-DVA	Config. Server	Config. Server	Config. Server, E-DVA	Mandatory
V152	Boolean Default: TRUE (or ON)	Non-volatile	Per E-DVA	Config. Server	Config. Server	Config. Server, E-DVA	Mandatory
DTMF Relay	Boolean Default: TRUE (or ON)	Non-volatile	Per E-DVA	Config. Server	Config. Server	Config. Server, E-DVA	Mandatory
RTCPXR Publish_report	IP address	Non-volatile	Per E-DVA	Config. Server	Config. Server	Config. Server, E-DVA	Mandatory
RTCPXR	Boolean Default: TRUE (or ON)	Non-volatile	Per E-DVA	Config. Server	Config. Server	Config. Server, E-DVA	Mandatory
RTCP_RATE	Integer (secs) Range: 0-60 Increments: 1 Default: 5	Non-volatile	Per E-DVA	Config. Server	Config. Server	Config. Server, E-DVA	Mandatory

A value of ON for T38 enables fax relay on the E-DVA. The E-DVA **MUST** enable T.38 operation as provisioned via the T.38 data element.

A value of ON for V152 enables modem relay on the E-DVA. The E-DVA **MUST** enable V.152 operation as provisioned via the V.152 data element.

A value of ON for DTMF Relay enables DTMF Relay on the E-DVA. The E-DVA **MUST** enable DTMF Relay operation as provisioned via the DTMF Relay data element.

Publish\_report defines the network address that receives the call statistics report from the E-DVA. The E-DVA **MUST** send Publish reports at the end of each call.

RTCPXR determines if extended reports for the sake of voice metrics are included within RTCP packets. A value of ON enables RTCP extended reports. Voice metrics can include network and audio metrics as defined in [CODEC-MEDIA].

RTCP\_RATE sets the interval at which RTCP packets are sent from the E-DVA. A value of zero for RTCP\_RATE disables RTCP transmission. The E-DVA **MUST** send RTCP packets at the rate indicated in the RTCP\_RATE data element.

If a voice call is switched to T.38 or V.152, the E-DVA **MUST** use the same packet period as the prior voice stream for transmitting data.

## 8.5 Loopback Test Capability

The PacketCable network may initiate a test call to the E-DVA to request that the E-DVA then be set into loopback mode such that network can send RTP streams to the E-DVA, and receive the same stream back. This allows the network operator to test the voice path and, potentially, a number of voice/packet performance statistics.

### 8.5.1 Test Call Request Encoding

The PacketCable network indicates, via a specific encoding scheme in the SIP INVITE, that the request is to initiate a test call and enable RTP loopback.

To indicate an RTP loop back test call, the INVITE received from the network MUST be encoded with:

- A Require header containing the option tag 'answermode' (reference [ID SIP ANSWERMODE]).
- An Answermode header containing the parameters 'auto;require'.
- SDP attribute 'loopback' indicating the specific loopback behavior required (reference [ID MMUSIC LOOPBACK]).
- SDP attribute 'loopback-source' indicating that the network is the source of the media that is to be the subject of the RTP loopback.

### 8.5.2 E-DVA Requirements on Reception of a Loopback Request

On reception of an INVITE request encoded as defined in this section, the E-DVA MUST:

- Not alert the subscriber.
- Provide a 200 OK final response to the INVITE.
- Encode the answer SDP provided in the 200 OK according to the rules in reference [ID MMUSIC LOOPBACK]).

On reception of RTP packets from the network, once a Loopback mode has been established, the action at the E-DVA is dependent on the contents of the 'loopback' attribute received in the offering SDP from the network.

If the 'loopback' attribute was encoded as 'rtp-pkt-loopback,' then E-DVA MUST NOT decode the received RTP packet and instead sends the received packet back to the network. The destination IP address and port for the looped RTP is that given in the offering SDP in the initial INVITE.

If the 'loopback' attribute was encoded as 'rtp-media-loopback,' then the E-DVA MUST decode and then re-encode the received RTP payload before sending the received packet back to the network if the E-DVA supports media loop back mode. The destination IP address and port for the looped RTP is that given in the offering SDP in the initial INVITE. The E-DVA MUST reject the INVITE with the 'rtp-media-loopback' if the E-DVA does not support the media loopback mode.

The Loopback test session ends upon reception of a BYE from the network on the dialog established by the initial INVITE.

The E-DVA MUST reject an INVITE request encoded as defined in Section 8.5.1 if it has insufficient resources to meet the requirements of the loopback mode. For example, the E-DVA may already be involved in a 3-way call.

The E-DVA SHOULD end the loopback mode with a BYE if a user request for a 3-way call cannot be serviced due to resource limitations.

## 8.6 Announcements

For the E-DVA, an Announcement is defined as the application of an analog signal to the two wire telephony port (RJ-11 analog telephone interface) to provide the end user or device information with respect to a call request or status change. These announcements could be analog audio tones or analog voice or music announcements and be provisioned on the E-DVA or on a network announcement source. When an E-DVA needs to present an announcement from a network announcement source, the audio format is negotiated between the E-DVA and the source of the announcement content.

Acoustic or visual announcements by the E-DVA are outside of the scope of this document.

### 8.6.1 Feature Description

North American telephony standards define minimum analog line announcements as a set of tones that are required for specific services or connection status (references [SR-2275], [GR 506], [GR 674], and [GR 675]).

The E-DVA **MUST** support the analog line tones listed in the referenced Telcordia standards for analog telephony services of the target market, physical location or operator directive within the constraints of this section. The specific tones are provisioned and map to the tone-identifiers defined in this document. Tone frequencies, formats, amplitudes, DCbias, and cadences are provisioned on the E-DVA.

In addition to these announcement tones, the E-DVA **MAY** also be capable of requesting audio announcements to be applied to the analog line from a network announcement application server. [BR 780-200-020] defines text for audio announcements. The E-DVA **MAY** provide audio announcements from an internal, provisioned, audio application server to the analog line.

In addition to the analog line signals, the E-DVA could present acoustic or visual displays equivalent to the tone and voice announcements. Acoustic or visual announcements by the UEs are outside of the scope of this document.

Therefore, there are two types of announcements in PacketCable: tone and audio announcements.

### 8.6.2 Tone Media

Network initiated tone announcement addresses for the alert info header for E-DVA internally stored or generated tones use the format file:///PacketCableRST/<tone-identifier> where the < tone-identifier > element is per Table 9.

**Table 9 - Announcement Tone Identifiers**

Meaning / Description	< tone-identifier >	Definition
DTMF tones	0-9,*,#,A, B,C,D	Detection and generation of DTMF signals is described in [GR 506]. It is considered an error to try and play DTMF tones on a phone that is on hook and an error should consequently be returned when such attempts are made (error code 402 – phone on hook).
Busy tone	bz	Station Busy is a combination of two AC tones with frequencies of 480 and 620 Hertz and levels of –24 dBm each, to give a combined level of –21 dBm. The cadence for Station Busy Tone is 0.5 seconds on followed by 0.5 seconds off, repeating. See [GR 506] for details. It is considered an error to try and play busy tone on a phone that is on hook and an error should consequently be returned when such attempts are made (error code 402 – phone on hook).
Confirmation tone	cf	Confirmation Tone uses the same frequencies and levels as dial tone (350 and 440 Hertz ) but with a cadence of 0.1 second on, 0.1 second off repeated three times. See [GR 506] for details. It is considered an error to try and play confirmation tone on a phone that is on hook and an error should consequently be returned when such attempts are made (error code 402 – phone on hook).
Dial tone	dl	Dial Tone is a combination of two continuous AC tones with frequencies of 350 and 440 Hertz and levels of –13dBm each to give a combined level of –10 dBm. See [GR 506] for details. It is considered an error to try and play dial-tone on a phone that is on hook and an error should consequently be returned when such attempts are made (error code 402 – phone on hook).

Meaning / Description	< tone-identifier >	Definition
Message waiting indicator	mwi	Message Waiting indicator tone uses the same frequencies and levels as dial tone (350 and 440 Hertz at -13dBm each), but with a cadence of 0.1 second on, 0.1 second off repeated 10 times followed by steady application of dial tone. See [GR 506] for details. It is considered an error to try and play message waiting indicator on a phone that is on hook and an error should consequently be returned when such attempts are made (error code 402 – phone on hook).
Off-hook warning tone	ot	Receiver Off Hook Tone (ROH Tone) is the irritating noise a telephone makes when it is not hung up correctly. ROH Tone is generated by combining four tones at frequencies of 1400 Hertz, 2060 Hertz, 2450 Hertz and 2600 Hertz at a cadence of 0.1 second on, 0.1 second off, repeating. [GR 506] contains details about required power levels. It is considered an error to try and play off-hook warning tone on a phone that is on hook and an error should consequently be returned when such attempts are made (error code 402 – phone on hook).
Distinctive ringing (0..7)	r0, r1, r2, r3, r4, r5, r6 or r7	See [GR 506] for details. The values for r1 to r5 are as defined for distinctive ringing pattern 1 to 5 as defined in [GR 506]. The provisioning process MAY define the ringing cadence for each of the r0-r7 signals. The E-DVA MUST support provisioning for r0, r6 and r7. It is considered an error to try and ring a phone that is off hook and an error should consequently be returned when such attempts are made (error code 401 – phone off hook).
Ringing	rg	See [GR 506] for details. The value for rg is as defined for distinctive ringing pattern 1 as defined in [GR 506]. The provisioning process MAY define the ringing cadence. The ringing signal may be parameterized with the signal parameter "rep" which specifies the maximum number of ringing cycles (repetitions) to apply. The following will apply the ringing signal for up to 6 ringing cycles: S: rg(rep=6) It is considered an error to try and ring a phone that is off hook and an error should consequently be returned when such attempts are made (error code 401 – phone off hook).
Reorder tone	ro	Reorder tone is a combination of two AC tones with frequencies of 480 and 620 Hertz and levels of -24 dBm each, to give a combined level of -21 dBm. The cadence for reorder tone is 0.25 seconds on followed by 0.25 seconds off, repeating continuously. See [GR 506] for details. It is considered an error to try and play reorder tone on a phone that is on hook and an error should consequently be returned when such attempts are made (error code 402 – phone on hook).
Ringsplash	rs	Ringsplash, also known as "Reminder ring" is a burst of ringing that may be applied to the physical forwarding line (when idle) to indicate that a call has been forwarded and to remind the user that a Call Forwarding subfeature is active. In the US, it is defined to be a 0.5(-0,+0.1) second burst of power ringing. The provisioning process MAY define the cadence for ringsplash. It is considered an error to try and ring a phone that is off hook and an error should consequently be returned when such attempts are made (error code 401 – phone off hook).
Ring back tone	rt	Audible Ring Tone is a combination of two AC tones with frequencies of 440 and 480 Hertz and levels of -19 dBm each, to give a combined level of -16 dBm. In the U.S. the cadence for Audible Ring Tone is defined to be 2 seconds on followed by 4 seconds off. The definition of the tone is defined by the national characteristics of the Ringback Tone, and MAY be established via provisioning. See [GR 506] for details. The ringback signal can be applied to both an endpoint and a connection. When the ringback signal is applied to an endpoint, it is considered an error to try and play ring back tones, if the endpoint is considered on hook and an error should consequently be returned when such attempts are made (error code 402 – phone on hook). When the ringback signal is applied to a connection, no such check is to be made.
Stutter dial tone	sl	Stutter Dial Tone (also called Recall Dial Tone) is generated by supplying Confirmation Tone, followed by continuous Dial Tone. See [GR 506] for details. The stutter dial tone signal may be parameterized with the signal parameter "del" which will specify a delay in milliseconds to apply between the confirmation tone and the dial tone (e.g., this feature is needed for Speed Dialing). The following will apply stutter dial tone with a delay of 1.5 seconds between the confirmation tone and the dial tone: S: sl(del=1500) It is considered an error to try and play stutter dial tone on a phone that is on hook and an error should consequently be returned when such attempts are made (error code 402 – phone on hook).

Meaning / Description	< tone-identifier >	Definition
Call waiting tones	wt1, wt2, wt3, wt4	<p>Call Waiting tones are defined in [GR 506] for details – the number refers to the tone pattern used. The duration of the tone pattern lasts for up to 1 second. Two tone patterns should be played separated by a period of 10 seconds. The default maximum number of repetitions and delay between repetitions may be altered by the provisioning process. The default Call Waiting tone is a 440-Hz tone applied for 300 ± 50 ms. The talking path should be interrupted for a maximum of 400 ms for the application of each CW tone pattern. When this signal is requested, the embedded client will play the two tone patterns as specified in [GR 506] before the "TO" signal times out. It is considered an error to try and apply call waiting tones on a phone that is on hook and an error SHOULD consequently be returned when such attempts are made (error code 402 – phone on hook).</p> <p>The default time-out is calculated based on the default (or provisioned) number of repetitions, default (or provisioned) delay between repetitions and length of time to generate the call waiting tone itself (1 second). For example, if Call Waiting Delay is set to 12 seconds and Call Waiting Maximum Number of Repetitions is set to 2, then the call waiting tone will be heard up to three times (played once and repeated twice). Therefore, the default time-out is calculated by adding the length of time it takes to play the call waiting tone three times (3 seconds) and the delay between repetitions (2 * 12 seconds). The calculated default timeout in this example is therefore 27 seconds. Upon request the call waiting signal may be parameterized with the signal parameter "to" which in essence overrides the calculated default timeout described above.</p>
DTMF tones wildcard	X	The DTMF tones wildcard matches any DTMF digit between 0 and 9.

Network generated tones or Network directed tone generation must use the same <tone-identifier> convention for signaling of the desired tone.

### 8.6.3 Tone and Announcement Media

When supplied by the Application Server, the URL provided in the `annc-url` shall use one of the following URL schemes:

`sip:` Indicates that the E-DVA SHOULD pass the `prompt_url` to the configured Media Server in an INVITE request to establish an RTP session for the announcement.

`ftp:` Indicates that the E-DVA SHOULD download the announcement media from remote storage to play out locally. The E-DVA MAY look for cached announcement media in local storage.

`http:` Indicates that the E-DVA SHOULD download the announcement media from remote storage to play out locally. The E-DVA MAY look for cached announcement media in local storage.

If the Application Server provides an announcement address using any other URL scheme, the E-DVA MAY forward the announcement address to the configured Media Server in an INVITE request to establish an RTP session for the announcement. Otherwise, the E-DVA applies the locally provisioned tone or announcement appropriate to the request or response code.

PacketCable supports the following basic categories of audio announcements, as described in [BR 780-200-020]. All network announcements, whether provisioned locally on the E-DVA or referenced to resources in the network, are identified by an announcement identifier. Table 10 describes announcement categories and conditions and the associated Announcement Identifiers. The provisioning reference for these announcements is [SR-2275].

**Table 10 - Announcement Identifiers**

Category/Condition	Announcement	Announcement Identifier
Reorder/All Circuits Busy	"Your call cannot be completed at this time. Please hang up and try again later."	Annc-Reorder
Reorder/Protocol Errors	"Your call cannot be completed at this time. Please hang up and try again later."	Annc-Reorder
Vacant Code/No Route	"Your call cannot be completed as dialed. Please check the number and try again."	Annc-Vacant
Intercept/Number Change	Implementation dependent.	Annc-NumberChg
Intercept/Disconnected Number	"The number that you have reached has been disconnected. Please check the number and try again."	Annc-Disconnected

Category/Condition	Announcement	Announcement Identifier
Intercept/Nonworking Number	"The number that you have reached is not in service. Please check the number and try again."	Annc-NonWorking
Intercept/Temporary Suspension	Implementation dependent.	Annc-TempSusp
Intercept/Incoming Call Restriction	"The number you have reached can not accept your call at this time. Please hang up and try again later."	Annc-Dencline
No Circuit	"Your call cannot be completed at this time. Please hang up and try again later."	Annc-NoCircuit
Ineffective/Dialing Irregularity	"Your call cannot be completed as dialed. Please check the number and try again."	Annc-DialError
Ineffective/Screened Line Access Denial	Implementation dependent.	Annc-AccessDenied

The E-DVA MAY be provisioned to map SIP response codes to announcements. However, to minimize the complexity of the E-DVA, the E-DVA MAY use the SIP Response Code to format the prompt\_url in the INVITE message that it sends to the network announcement source. The format of the prompt\_url is:

```

sip:annc<operator_announcement_domain>
play=file://<announcement_network_path>/<response_code>.<announcement_mime_type>

```

The E-DVA could be provisioned to identify, locate, and play announcements based on the presence of Alert-info headers or Contact headers provided by other network elements in response messages, or simply by the response code if no announcement is requested. The Response codes and Announcement Identifiers may be found in the Announcement Map specified in [RSTF].

When there is a matching entry, the E-DVA MUST retrieve the Announcement Identifier from the entry and use this to retrieve the Announcement URI from the Announcement Media Map as specified in [RSTF]. The Announcement URI could specify a locally stored announcement, tone, or bell cadence by using the file syntax, in which case the E-DVA MUST look up the alert media in its Local Media Table, provisioned as per [RSTF].

When there is no entry in the Announcement Map for a response code, the E-DVA MAY construct a URI following the procedure described in [RSTF] Announcements section.

Table 11 summarizes the feature data elements defined to support implementation of the tone and audio announcement features.

**Table 11 - Announcement Types**

Data	Type	Persistence	Scope	Stored by	Written by	Read by	Config. Server Requirement
E-DVA Tone Identifiers	Character string	Non-volatile	Per E-DVA	Config. Server	Config. Server	Config. Server, E-DVA	Mandatory
E-DVA Audio Announcement Identifiers	Character string	Non-volatile	Per E-DVA	Config. Server	Config. Server	Config. Server, E-DVA	Optional

## 9 E-DVA MONITORING REQUIREMENTS

The E-DVA is a critical element in the PacketCable architecture. It provides the customer's interface to the service provider's network, and is located outside the service provider's head end. As such, it is critical that the operational status of the E-DVA be monitored in order to provide the quickest information to the service provider. In particular, if the E-DVA fails and is not capable of providing the intended service, the service provider will need to know about this condition quickly (preferably before the customer).

The minimum goal of fault management should be to isolate failures to a field replaceable unit. Preferably, fault management should be able to identify the failed functional subsystem within the unit. This enables the service provider to dispatch service personnel with the appropriate equipment necessary to trouble-shoot and resolve the problem in the least amount of time (i.e., minimize Mean Time To Replacement, or MTTR).

This section provides the E-DVA monitoring requirements in support of proper fault management. Specifically, it provides the monitoring requirements for three main functional subsystems of the E-DVA: the DOCSIS eCM, the PacketCable E-DVA, and the battery-backup module.

### 9.1 eCM Monitoring

The E-DVA functions as the customer premise network interface to the PacketCable network and thus enables service to the customer. In particular, within the eDOCSIS-compliant E-DVA, the eCM provides the critical connection between the E-DVA and the PacketCable network [eDOCSIS]. An eCM failure will affect the availability of the PacketCable service.

The E-DVA **MUST** support the eCM failure detection mechanisms defined by DOCSIS specifications [DOCSIS RFIv2.0], [DOCSIS OSSIV2.0], and [eDOCSIS].

### 9.2 E-DVA Monitoring

At the minimum, the E-DVA monitoring **MUST** utilize the eCM failure detection mechanisms defined by DOCSIS specifications [DOCSIS RFIv2.0], [DOCSIS OSSIV2.0], and [eDOCSIS].

Additional vendor-specific E-DVA monitoring mechanisms **MAY** be developed. Such mechanisms can include internal on-line diagnostics utilized to detect vendor specific events.

For the report of the E-DVA failures, the E-DVA **MUST** support the event and alarm reporting mechanisms as defined in [RST E-UE PROV].

### 9.3 Battery-Backup Monitoring

To maintain operation during the utility AC power outage, the E-DVA **MAY** provide local power with uninterruptible power supply (UPS) battery backup. If the UPS is provided, the E-DVA **MUST** support the On Battery, AC Restored, Battery Bad, Battery Good, Battery Missing, Battery Present, Depleted Battery, and Battery Charging alarm state telemetry signals for the monitoring of the battery-backup module. For the report of these telemetry signals, the E-DVA **MUST** support the event and alarm reporting mechanisms as defined in [RST E-UE PROV].

## Appendix I Acknowledgements

PacketCable wishes to recognize the following individuals for their significant involvement and contributions to this specification:

Steve Hughey (Arris)

Gordon Li (Broadcom)

Brent Agnew (Broadsoft)

Steve Dotson, Ike Elliott, Kevin Johns, Bernard McKibben (CableLabs)

Geoff Devine (CedarPoint)

Moh Torabi (Lucent)

Phil Freyman and Bob Stein (Motorola)

John Gilmore, Kevin Boyle (Nortel)

Mark Trayer (Samsung)

Tom Miller (Siemens)

John Bartusek, and Satish Kumar (Texas Instruments)

*Sandeep Sharma (CableLabs)*

## Appendix II Revision History

The following Engineering Change Notices were incorporated in PKT-SP-RST-E-DVA-I02-070925.

<b>ECN</b>	<b>ECN Date</b>	<b>Summary</b>
RST-E-DVA-N-07.0447-3	6/18/07	Update the Requirements on Ring Trip Immunity, Time Keeping, and Telemetry Events
RST-E-DVA-N-07.0466-3	6/25/07	Added Announcements subsection
RST-E-DVA-N-07.0469-2	7/16/07	Alignment with 3GPP IMS Release 7 and other reference updates

The following Engineering Change Notices were incorporated in PKT-SP-RST-E-DVA-I03-080425.

<b>ECN</b>	<b>ECN Date</b>	<b>Summary</b>
RST-E-DVA-N-07.0494-4	11/5/07	PACM Spec Withdrawal E-DVA Impacts
RST-E-DVA-N-08.0508-2	3/24/08	Updates for 3GPP Dec 07 R7 alignment and IETF updates

---