

PacketCable™

**PacketCable Residential SIP
Telephony Accounting Specification**

PKT-SP-RST-ACCT-I03-080425

ISSUED

Notice

This PacketCable specification is the result of a cooperative effort undertaken at the direction of Cable Television Laboratories, Inc. for the benefit of the cable industry and its customers. This document may contain references to other documents not owned or controlled by CableLabs. Use and understanding of this document may require access to such other documents. Designing, manufacturing, distributing, using, selling, or servicing products, or providing services, based on this document may require intellectual property licenses from third parties for technology referenced in this document.

Neither CableLabs nor any member company is responsible to any party for any liability of any nature whatsoever resulting from or arising out of use or reliance upon this document, or any document referenced herein. This document is furnished on an "AS IS" basis and neither CableLabs nor its members provides any representation or warranty, express or implied, regarding the accuracy, completeness, noninfringement, or fitness for a particular purpose of this document, or any document referenced herein.

© Copyright 2006-2008 Cable Television Laboratories, Inc.
All rights reserved.

Document Status Sheet

Document Control Number:	PKT-SP-RST-ACCT-I03-080425			
Document Title:	PacketCable Residential SIP Telephony Accounting Specification			
Revision History:	I01 - Released 9/27/06			
	I02 - Released 9/25/07			
	I03 - Released 4/25/08			
Date:	April 25, 2008			
Status:	Work in Progress	Draft	Issued	Closed
Distribution Restrictions:	Author Only	GL/Member	GL/Member/ Vendor	Public

Key to Document Status Codes

- Work in Progress** An incomplete document, designed to guide discussion and generate feedback that may include several alternative requirements for consideration.

- Draft** A document in specification format considered largely complete, but lacking review by Members and vendors. Drafts are susceptible to substantial change during the review process.

- Issued** A stable document, which has undergone rigorous member and vendor review and is suitable for product design and development, cross-vendor interoperability, and for certification testing.

- Closed** A static document, reviewed, tested, validated, and closed to further engineering change requests to the specification through CableLabs.

Trademarks

CableLabs®, DOCSIS®, EuroDOCSIS™, eDOCSIS™, M-CMTS™, PacketCable™, EuroPacketCable™, PCMM™, CableHome®, CableOffice™, OpenCable™, OCAP™, CableCARD™, M-Card™, DCAS™, and tru2way™ are trademarks of Cable Television Laboratories, Inc.

Contents

1	SCOPE	1
1.1	Introduction and Purpose	1
1.2	Requirements	1
2	REFERENCES	2
2.1	Normative References	2
2.2	Informative References	2
2.3	Reference Acquisition	2
3	TERMS AND DEFINITIONS	3
4	ABBREVIATIONS AND ACRONYMS	4
5	TECHNICAL OVERVIEW	5
5.1	PacketCable Accounting Architecture	5
5.1.1	Functional Entities	5
5.2	Design Goals	6
5.3	Scope	6
6	PACKETCABLE SERVICES	7
6.1	PacketCable Call Configurations	7
6.1.1	On-Net to On-Net Call Configuration	7
6.2	Specific Services	9
6.2.1	Call Forwarding	9
6.2.2	Call Blocking	15
6.2.3	Call Transfer	24
6.2.4	Auto Recall (for Anonymous Calls Only)	27
6.2.5	Auto Callback (for Anonymous Calls Only)	34
6.2.6	Operator Services	34
6.2.7	COT	35
7	DEFINITION OF ACCOUNTING INFORMATION	37
7.1	Data Description for RST Offline Accounting	37
7.1.1	Rf Message Contents	37
7.2	RST Specific Parameters	38
7.2.1	Definition of the RST Information	38
7.2.2	RST Specific AVPs	38
APPENDIX I ACKNOWLEDGEMENTS		42
APPENDIX II REVISION HISTORY		43

Figures

Figure 1 - PacketCable Accounting Reference Architecture.....	5
Figure 2 - Generic RST Feature Invocation	7
Figure 3 - Call Forward Establishment.....	12
Figure 4 - Call Forward Activation with a User-Provided Address	13
Figure 5 - Remote Activation of Call Forwarding.....	15
Figure 6 - Outbound Call Blocking (OCB) - Feature Deactivated.....	17
Figure 7 - OCB Invalid Override PIN	18
Figure 8 - OCB - Valid Override PIN	19
Figure 9 - OCB Override PIN Service Not Enabled	20
Figure 10 - SCB - Called Party Accepts.....	22
Figure 11 - SCB - Called Party Rejects or Fails to Respond to IVR.....	23
Figure 12 - SCB - Calling Party Fails to Enter a Greeting	24
Figure 13 - Call Transfer Establishment.....	27
Figure 14 - Successful AR Accounting Flow Diagram	30
Figure 15 - Delayed Successful AR Accounting Flow Diagram.....	32
Figure 16 - Unsuccessful AR Accounting Due to Time Expiration.....	33
Figure 17 - COT Accounting Flow	36

Tables

Table 1 - Call Transfer ACR Event AVPs for 202 Accepted.....	25
Table 2 - Call Transfer ACR Event AVPs for 200 OK.....	26
Table 3 - Offline Charging Messages Reference Table.....	37
Table 4 - Service Information used for RST	38
Table 5 - Structure of the RST-Information	38
Table 6 - RST specific AVPs	39

1 SCOPE

1.1 Introduction and Purpose

The purpose of this specification is to define the collection of usage data needed to support Accounting of Residential SIP Telephony (RST) Features. In addition to defining how the collection of usage data is done, this specification details the various accounting events and their associated attributes. The PacketCable Accounting framework and generic requirements are defined in the PacketCable Accounting specification [ACCT], on which this specification is based.

Residential SIP Telephony (RST) Features are defined in the RST Features specification [RSTF]. Accounting procedures for a sub-set of those features defined by the RST specification are defined in this document. In particular, the RST specification defines both UE-based and network-based features. UE-based features are executed locally by the UE-based on some locally defined criteria (i.e., matching a feature code to an internal digit map for feature execution). Such features cannot be accounted for, as there are no accounting records created by the UE. Sessions resulting from local feature execution can be accounted for using standard accounting procedures. However, the reason for the session establishment will not always be known by the network. There are some locally executed features, e.g., three-way calling, that may be detectable by the billing support system through post processing of accounting records (i.e., if the billing support system sees two sets of seemingly unrelated accounting events for which both sessions were active at the same time, it can infer that a three-way call was made).

Network-based features on the other hand are executed in the network by an application server. This server provides feature execution as defined by the RST specification. Given that application servers can generate accounting events, the features executed by application servers can be accounted for. Given that PacketCable Accounting does not define Accounting for application servers, this specification defines the accounting records the application server generates based on the feature being executed.

PacketCable is a CableLabs specification effort designed to extend cable's real-time IP communication service architecture and to accelerate the convergence of voice, video, data, and mobility technologies.

1.2 Requirements

Throughout this document, the words that are used to define the significance of particular requirements are capitalized. These words are:

"MUST"	This word means that the item is an absolute requirement of this specification.
"MUST NOT"	This phrase means that the item is an absolute prohibition of this specification.
"SHOULD"	This word means that there may exist valid reasons in particular circumstances to ignore this item, but the full implications should be understood and the case carefully weighed before choosing a different course.
"SHOULD NOT"	This phrase means that there may exist valid reasons in particular circumstances when the listed behavior is acceptable or even useful, but the full implications should be understood and the case carefully weighed before implementing any behavior described with this label.
"MAY"	This word means that this item is truly optional. One vendor may choose to include the item because a particular marketplace requires it or because it enhances the product, for example; another vendor may omit the same item.

2 REFERENCES

2.1 Normative References

In order to claim compliance with this specification, it is necessary to conform to the following standards and other works as indicated, in addition to the other requirements of this specification. Notwithstanding, intellectual property rights may be required to use or implement such normative references.

- [ACCT] PacketCable Accounting Specification, PKT-SP-ACCT-I04-080425, April 25, 2008, Cable Television Laboratories, Inc.
- [RSTF] PacketCable Residential SIP Telephony Feature Specification, PKT-SP-RSTF-I03-080425, April 25, 2008, Cable Television Laboratories, Inc.
- [TS 32.240] 3GPP TS 32.240, Charging Architecture and Principles, Release 7, V7.2.0, March 2007.
- [TS 32.260] 3GPP TS 32.260, IP Multimedia Subsystem (IMS) charging, Release 7, V7.4.0, October 2007.
- [TS 32.299] 3GPP TS 32.299, Diameter charging applications, Release 7, V7.7.0, October 2007.

2.2 Informative References

This specification uses the following informative references.

- [PKT 24.229] PacketCable SIP and SDP Stage 3 Specification 3GPP TS 24.229, PKT-SP-24.229-I04-080425, April 25, 2008, Cable Television Laboratories, Inc.
- [RFC 3588] IETF RFC 3588, Diameter Base Protocol, September 2003.
- [TS 23.228] 3GPP TS 23.228, IP Multimedia Subsystem (IMS) Stage 2, Release 7, V7.10.0, December 2007.
- [TS 32.251] 3GPP TS 32.251, Telecommunication management; Charging management; Packet Switched (PS) domain charging, Release 7, V7.5.1, October 2007.

2.3 Reference Acquisition

- Cable Television Laboratories, Inc., 858 Coal Creek Circle, Louisville, CO 80027; Phone 1+303-661-9100; Fax 1+303-661-9199; Internet: <http://www.cablelabs.com/>
- Internet Engineering Task Force (IETF), Internet: <http://www.ietf.org>
- Third Generation Partnership Project (3GPP), Internet: <http://www.3gpp.org>

3 TERMS AND DEFINITIONS

This specification uses the following terms:

Accounting	The process of collecting usage data
DIAMETER	The Diameter protocol provides an Authentication, Authorization and Accounting (AAA) framework for applications such as network access or IP mobility
Charging	The process of applying rating to usage data for a given session for the generation of a subscriber's bill
HFC Access Network	The Hybrid-Fiber Coax Network, which provides physical transport of video and high speed data services via DOCSIS
Usage Data	A collection of data representing the usage of network resources for a given session

4 ABBREVIATIONS AND ACRONYMS

This specification uses the following abbreviations:

3GPP	Third Generation Partnership Project
AC	Automatic Callback
ACA	Accounting-Answer
ACR	Accounting-Request
AR	Auto Recall
AS	Application Server
AVP	Attribute Value Pair
B2BUA	Back-to-Back User Agent
CDF	Charging Data Function
CF	Call Forwarding
CFDA	Call Forwarding Don't Answer
CFV	Call Forwarding Variable
CSCF	Call Session Control Function
ICID	IMS Charging ID
IMPU	IMS Public Identity
IMS	IP Multimedia Subsystem
IOI	Inter-Operator Identifier
IVR	Interactive Voice Responder
LIDB	Line Identification Database
OCB	Outbound Call Blocking
P-CSCF	Proxy-CSCF
RACF	Remote Activation of Call Forwarding
RST	Residential SIP Telephony
SCB	Solicitor Call Blocking
S-CSCF	Serving-CSCF
UE	User Equipment

5 TECHNICAL OVERVIEW

5.1 PacketCable Accounting Architecture

Figure 1 depicts the PacketCable Accounting reference architecture, as described in PacketCable Accounting [ACCT].

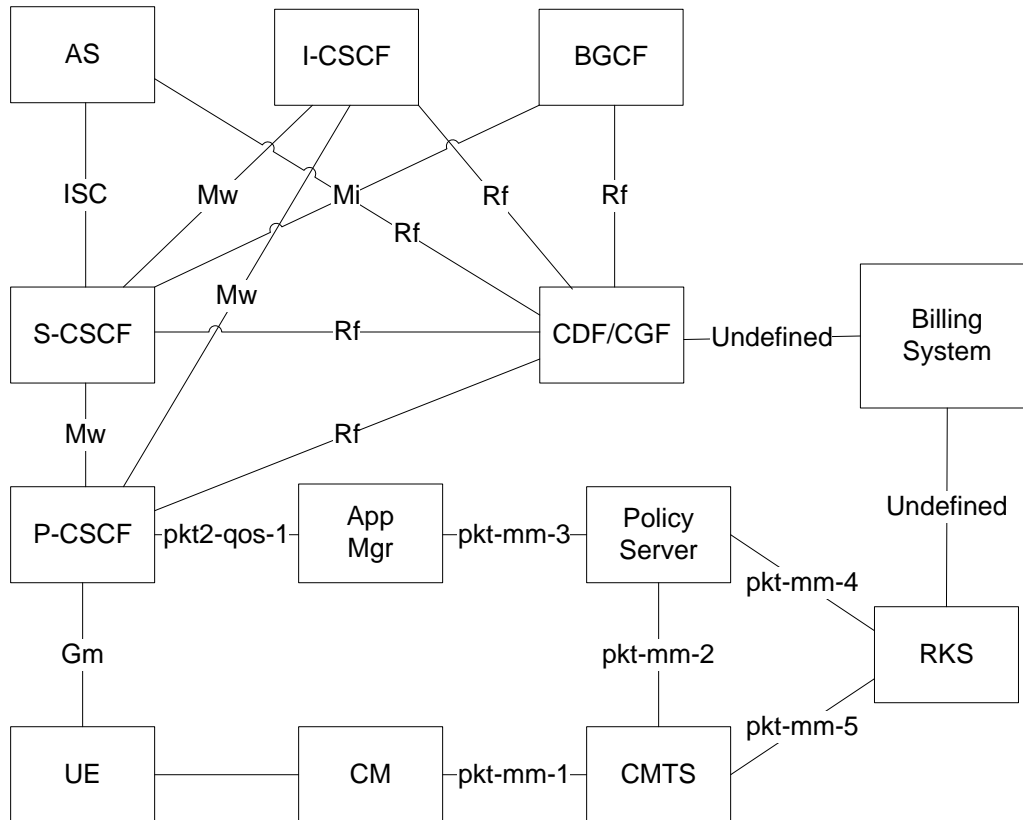

Figure 1 - PacketCable Accounting Reference Architecture

The PacketCable Residential SIP Telephony (RST) Feature specification [RSTF] leverages PacketCable as the underlying SIP-based network. The RST Application Server implements the application level network functionality for the RST service, and is essentially seen as an Application Server from the PacketCable perspective. Consequently, communications between the PacketCable network and the RST Application Server utilize the ISC interface defined in 3GPP [TS 23.228].

As described in the following sections, only the RST Application Server is relevant for accounting of RST Features.

5.1.1 Functional Entities

The next two sections discuss the RST functional entities; RST Client and RST Application Server are presented as described in [RSTF]. Also, different roles of the RST server that impact the RST accounting architecture are described.

5.1.1.1 RST Client (UE)

The RST Client resides on the UE and is used to access RST services. References to simply a UE in this specification imply a UE with an RST Client accessing RST services.

5.1.1.2 RST Application Server

The RST Application server implements the application level network functionality for the RST service.

The RST application server may be either a back-to-back user agent (B2BUA), or a forwarding proxy, depending on the feature definition in the RST Feature specification. For the features covered by this specification, the RST application server is expected to always act as a forwarding proxy. However, the accounting definitions should not prohibit B2BUA operation, should such an implementation be used.

5.2 Design Goals

The PacketCable RST Accounting architecture attempts to limit extensions of accounting events to the Application Server only. Changes to CSCF accounting events should be avoided whenever practically possible.

Extensions to accounting events should be contained to an RST-Information AVP group within the Service-Information AVP group as defined in [TS 32.260] and [TS 32.299].

5.3 Scope

Only those features that are network-executed are to be covered by this document. Those features that are UE-executed are not covered by this document, and thus not explicitly accounted for. As a result, this document only documents impacts to the AS to CDF interface. The CSCF to CDF interface is defined in the PacketCable Accounting specification [ACCT].

6 PACKETCABLE SERVICES

6.1 PacketCable Call Configurations

The architecture for PacketCable Accounting is documented in [ACCT]. All of the requirements on PacketCable Network Elements for reporting accounting information in that specification MUST be implemented in order to support the RST service. These requirements ensure that the data specific to the HFC access network can be properly correlated with the accounting data generated in the IMS domain. Further, PacketCable Network Elements MUST implement the Rf interface as defined in [TS 32.240], [TS 32.260], and [TS 32.299]. PacketCable Network Elements MUST support the P-Charging-Vector and P-Charging-Function-Address header requirements as defined in [PKT 24.229].

Additionally, [ACCT] describes the basic requirements on the PacketCable network elements, and provides a description of critical DIAMETER AVPs needed for PacketCable accounting.

In this specification, additional RST-specific requirements, primarily on the RST AS, are discussed.

The PacketCable charging model enables both session-based and event-based charging. Session-based charging uses ACRs of types Start, Interim, and Stop, while Event-based charging uses Event ACRs. PacketCable accounting uses all of these ACR types. In support of RST service features, event based charging is used in conjunction with the accounting defined for the PacketCable network elements.

6.1.1 On-Net to On-Net Call Configuration

As Figure 2 shows, the RST AS sends accounting data to the CDF via the Rf interface as defined in [TS 32.260] and [TS 32.299]. Data specific to the features being invoked are covered in detail in the specific feature sections. This section covers capabilities common to all of the RST features.

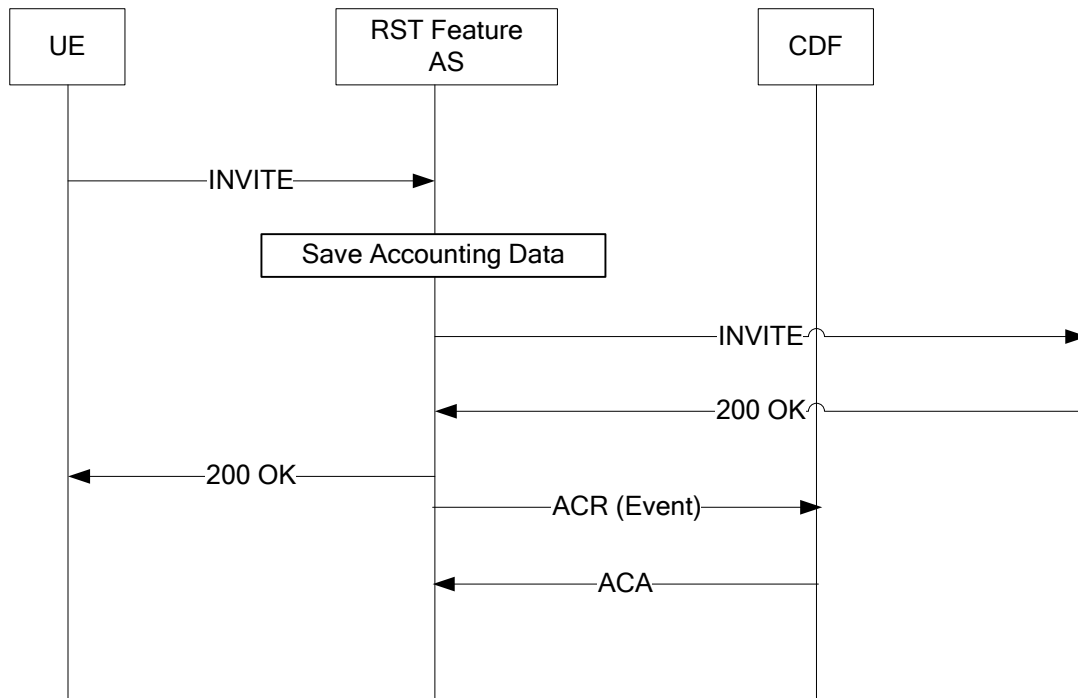

Figure 2 - Generic RST Feature Invocation

Figure 2 shows a generic example of how an RST feature may be invoked upon initiation of a session. Generally, the AS handling the feature request will generate an ACR message appropriate to the context of the feature. These AS-generated messages are of type Event for all of the defined RST features. In the example shown in Figure 2, the event message is sent when the 200 OK to the initial invite is received. In the actual feature descriptions, the context will define the appropriate trigger for sending an event ACR.

As in Figure 2, some of the critical AVPs are found in the Diameter Base data defined in [RFC 3588]. The rest are grouped in the IMS-Information AVP (ID 876), within the Service-Information AVP (ID 873), and defined in [TS 32.299]. Note that Diameter Base AVPs have IMS names that differ from the names in RFC 3588. This document uses the IMS name for initial reference of such AVPs, and includes the base name in parentheses along with the AVP ID. After the initial reference, only the IMS name is used.

6.1.1.1.1 *DIAMETER AVPs for Basic RST Feature Accounting Use*

The AVPs described in the list below and covered in [ACCT] apply to RST features. The RST AS MUST include the following AVPs in the ACR Event messages related to an RST feature activation or invocation:

- IMS-Charging-ID (AVP 841): Used by the CDF for correlation. If the AS is within the same trusted domain as the CSCF that made the feature request, the ICID will be provided to the AS in SIP signaling and the AS MUST use the provided ICID unless indicated otherwise in this specification. If the CSCF does not provide an ICID, the AS will generate a unique ICID for the signaling dialog.
- Operation Type (Accounting-Record-Type AVP 480) from the Diameter Base Data: Designates if the message is an ACR Start, Interim, Stop, or Event. This will help the CDF determine the context of the message.
- Node-Functionality (AVP 862): Identifies the type of the node that sent the accounting message (P-CSCF, S-CSCF, I-CSCF, AS). This will help the CDF determine the context of the message. The AS MUST set the node-functionality to AS.
- Originator Host (Origin-Host AVP 264) and Originator Domain (Origin-Realm AVP 296) in the Diameter Base data: Uniquely identify the node that sent the accounting message. The AS MUST set the originator host and originator domain as configured.
- Operation Number (Accounting-Record-Number AVP 485) from the Diameter Base Data: Provides a sequence number for ordering the accounting messages.
- Role-of-Node (AVP 829): Designates whether the element is originator, terminator, proxy, or B2BUA. This will allow the CDF/Billing System to determine whether it is receiving accounting messages for the originating or terminating side of a session.

The Inter-Operator-Identifier (AVP 838) is a grouped AVP that contains the Originating-IOI (AVP 839) and Terminating-IOI (AVP 840), wherever operator boundaries are crossed. This data will be used for settlements with interconnect operators. The specification [PKT 24.229] describes when the IOI is available to an IMS node. Whenever a PacketCable RST AS receives or sends inter-operator information in IMS signaling, it MUST include the IOI AVP in the ACR Event message.

6.1.1.1.2 *Subscriber Identification*

As described in [ACCT], Calling-Party-Address and Called-Party Address are used to identify the subscribers involved in an RST session. These are populated from the public identity headers and Request URI respectively.

When generating ACR Event messages, the RST AS MUST include the Calling-Party-Address AVP containing the entire contents of the P-Asserted-Identity header of the originator, if present. If the P-Asserted-Identity header is not present, then the RST AS MUST include the entire contents of the P-Preferred-Identity header if present. If both the P-Asserted-Identity and P-Preferred-Identity headers are not present, then RST AS MUST include the entire contents of the From header.

As with the S-CSCF, an RST AS commonly performs translations on the request URI. The reported value of the Called-Party-Address from the AS should be the address in the modified Request URI after all translations have been completed.

When generating ACR Event messages, the RST AS MUST include the Called-Party-Address AVP containing the entire contents of the Request URI of the terminator after applying all of the translations needed on the SIP Request.

The RST AS may be required to generate feature-specific accounting data with additional subscriber information. This additional data is defined in the specific feature sections.

6.1.1.1.3 RST Feature Timestamps

The following timestamp AVPs are included in RST AS messages:

- Origination Timestamp (Event-Timestamp AVP 55) from the Diameter Base Data: This is defined as the time that the "operation is requested," which generally means when the DIAMETER message is sent.
- SIP-Request-Timestamp (AVP 834): This AVP is used for the time when a SIP request message was sent.
- SIP-Response-Timestamp (AVP 835): This AVP is used for the time when a SIP response was received.

SIP-Request-Timestamp and SIP-Response-Timestamp are grouped under Time-Stamps (AVP 833).

The context of the specific RST feature will determine exactly how each of these timestamp AVPs are populated.

6.2 Specific Services

6.2.1 Call Forwarding

6.2.1.1 Call Forwarding Variable

Call forwarding Variable (CFV) is a feature that allows a subscriber to activate forwarding of all calls to the subscriber's public identity to another location. The forward-to address can be provided by the subscriber or by the network operator. With CFV, the forwarding happens immediately and the forwarded public identity has no opportunity to answer the call prior to the forwarding.

6.2.1.1.1 Accounting Procedures

The follow sections provide the detailed accounting procedures for each Call Forwarding Variable scenario.

6.2.1.1.1.1 CFV Establishment

The Call Forward Application Server (CF AS) MUST generate an ACR Event when it receives the 200 OK in response to the forwarded INVITE. The CF AS MUST set the Role-of-Node AVP to terminator. The CF AS MUST set the Server-Role AVP to Call Forwarding Variable, the Session-Type to session establishment, and the RST-Subscriber-ID to the IMS Public Identity (IMPU) of the forwarding party in the ACR Event. The CF AS MUST set the SIP-Response-Timestamp in the ACR Event to the time when received the 200 OK to the forwarded INVITE.

The Call Forward Application Server (CF AS) MUST generate an ACR Event when it receives an error in response (4xx, 5xx, or 6xx) to the forwarded INVITE. The CF AS MUST set the Role-of-Node AVP to terminator. The CF AS MUST set the Server-Role AVP to Call Forwarding Variable, the Session-Type to session establishment and the RST-Subscriber-ID to the IMPU of the forwarding party in the ACR Event.

The CF AS MUST set the SIP-Response-Timestamp in the ACR Event to the time when it sent the error response (4xx, 5xx, or 6xx) to the forwarded INVITE.

The CF AS MUST set the Cause-Code (AVP 861) indicating the response code received or sent by the CF AS.

When canceling a forwarded session, the CF AS MUST generate an ACR Event when it receives a 200 OK to a CANCEL. The CF AS MUST set the Role-of-Node AVP to terminator. The CF AS MUST set the Server-Role AVP to the Call Forwarding Variable, the Session-Type to session establishment and the RST-Subscriber-ID to the IMPU of the forwarding party in the ACR Event.

The CF AS MUST set the SIP-Response-Timestamp in the ACR Event to the time when it received the 200 OK to the forwarded CANCEL.

The CF AS MUST set the Cause-Code (AVP 861) to 2 "Unsuccessful session setup."

6.2.1.1.1.2 CFV Deactivation

The CF AS MUST generate an ACR Event when it sends the 200 OK in response to an INVITE received from the RST subscriber that deactivates CFV. The CF AS MUST set the Role-of-Node AVP to originator. The CF AS MUST set the Server-Role AVP to Call Forwarding Variable, the Session-Type to De-Activation, and the RST-Subscriber-ID to the IMPU of the forwarding party in the ACR Event.

The CF AS MUST set the SIP-Response-Timestamp to the time when it sends the 200 OK to the INVITE.

6.2.1.1.1.3 CFV Activation with User-provided Address

When the CF AS receives an INVITE, which indicates CFV Activation, and a user-provided address is present, the AS will forward the INVITE to the user-provided address. The CF AS MUST generate an ACR Event when it receives the 200 OK response to the forwarded INVITE. The CF AS MUST set the Role-of-Node AVP to originator. The CF AS MUST set the Server-Role AVP to Call Forwarding Variable, the Session-Type to activation, and the RST-Subscriber-ID to the IMPU of the forwarding party in the ACR Event.

The CF AS MUST set the SIP-Response-Timestamp to the time when it received the 200 OK response to the forwarded INVITE.

For the case where the forwarded to party does not answer or is busy, the CF AS MUST NOT generate an ACR Event. If a second CFV Activation to a user provided address is attempted within a two minute window, the CF AS MUST generate an ACR Event when it receives the first 18x or 486 (busy) response to the forwarded INVITE. The CF AS MUST set the Role-of-Node AVP to originator. The CF AS MUST set the Server-Role AVP to Call Forwarding Variable, the Session-Type to Activation, and the RST-Subscriber-ID to the IMPU of the forwarding party in the ACR Event.

The CF AS MUST set the SIP-Response-Timestamp to the time when it received the 18x or 486 (busy) response to the forwarded INVITE.

The CF AS MUST generate an ACR Event when it receives a non-busy error in response (4xx, 5xx, or 6xx) to the forwarded INVITE. The CF AS MUST set the Role-of-Node AVP to originator. The CF AS MUST set the Server-Role AVP to Call Forwarding Variable, the Session-Type to Activation, and the RST-Subscriber-ID to the IMPU of the forwarding party in the ACR Event.

The CF AS MUST set the SIP-Response-Timestamp in the ACR Event to the time when it received the error response (4xx, 5xx, or 6xx) to the forwarded INVITE.

The CF AS MUST set the Cause-Code (AVP 861) indicating the response code received by the CF AS.

6.2.1.1.1.4 CFV Activation to a Fixed Number

The CF AS MUST generate an ACR Event when it sends the 200 OK response to the INVITE received from the RST subscriber that activates CFV. The CF AS MUST set the Role-of-Node AVP to originator. The CF AS MUST set the Server-Role AVP to Call Forwarding Variable, the Session-Type to Activation, and the RST-Subscriber-ID to the IMPU of the forwarding party in the ACR Event.

The CF AS MUST set the SIP-Response-Timestamp to the time when it sent the 200 OK response to the INVITE.

The CF AS MUST generate an ACR Event when it sends an error in response (4xx, 5xx, or 6xx) to the INVITE received from the RST subscriber that activates CFV. The CF AS MUST set the Role-of-Node AVP to originator. The CF AS MUST set the Server-Role AVP to Call Forwarding Variable, the Session-Type to Activation, and the RST-Subscriber-ID to the IMPU of the forwarding party in the ACR Event.

The CF AS MUST set the SIP-Response-Timestamp in the ACR Event to the time when it sent the error response (4xx, 5xx, or 6xx) to the INVITE.

The CF AS MUST set the Cause-Code (AVP 861), indicating the response code sent by the CF AS.

6.2.1.1.1.5 UE SUBSCRIBE for Notification of a Forwarded Call

The CF AS, if configured to send ACR Event upon successful subscription, MUST generate an ACR Event when it sends the 200 OK in response to a SUBSCRIBE for Notification of a forwarded call. The CF AS MUST set the Role-of-Node AVP to originator. The CF AS MUST set the Server-Role AVP to Call Forwarding Variable, the Session-Type to Subscribe, and the RST-Subscriber-ID to the IMPU of the forwarding party in the ACR Event.

The CF AS MUST set the SIP-Response-Timestamp to the time when it sent the 200 OK response to the SUBSCRIBE.

6.2.1.1.1.6 Notification to UE of a Forwarded Call or Call Forwarding Activation Status

The CF AS, if configured to send ACR Event when sending NOTIFY messages, MUST generate an ACR Event when it receives the 200 OK response to a NOTIFY of a forwarded call or call forwarding activation status. The CF AS MUST set the Role-of-Node AVP to terminator. The CF AS MUST set the Server-Role AVP to Call Forwarding Variable, the Session-Type to Notify, and the RST-Subscriber-ID to the IMPU of the forwarding party in the ACR Event.

The CF AS MUST set the SIP-Response-Timestamp to the time when it received the 200 OK response to the NOTIFY.

6.2.1.1.2 DIAMETER Message Flows

6.2.1.1.2.1 Successful Call Forward Establishment

Figure 3 shows the Diameter transactions that are required between the Call Forward Application Server and the CDF during a Call Forward initiated for an RST subscriber. The 200 OK response to the call forward INVITE triggers an accounting action (ACR Event) in the Call Forward Application Server (CF AS). The CF AS does not remain in the signaling path after the INVITE transaction completes. The RST subscriber's S-CSCF will generate start and stop ACRs that will supply the details about the call session. The event ACR from the Call Forward Application Server can be correlated with the session records to allow the billing center to correctly associate the RST subscriber with the call leg to the forward-to party.

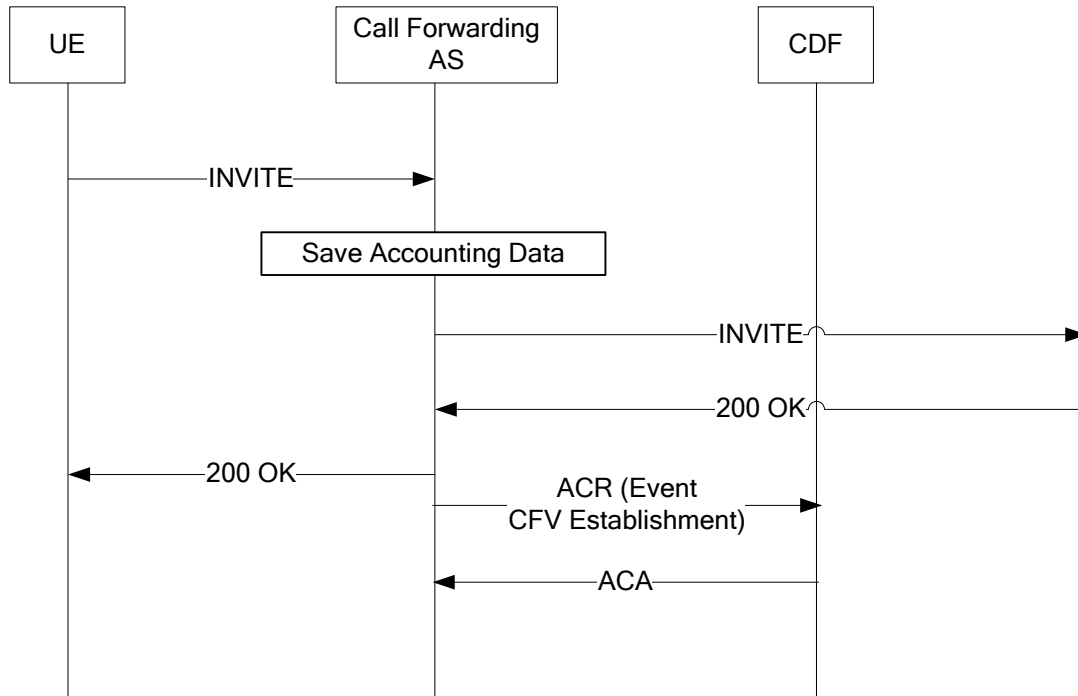

Figure 3 - Call Forward Establishment

6.2.1.1.2.2 Successful Call Forward Variable Activation with User-provided Address

Figure 4 shows the Diameter transactions that are required between Call Forward Application Server and the CDF when Call Forwarding is being activated by an RST subscriber with a user-provided address. In this case, the Call Forward Application Server proxies the INVITE to the user-provided address and the RST subscriber is connected thru to the forward-to address. The 200 OK response to the call forward INVITE triggers an accounting action in the Call Forward Application Server. The accounting action is distinguished from the normal Call Forwarding action by indicating that it is a CFV Activation vs. a CFV session establishment. The Call Forward Application Server does not remain in the signaling path after the INVITE transaction completes. The RST subscriber's S-CSCF will generate start and stop ACRs that will supply the details about the call session. The event ACR from the Call Forward Application Server can be correlated with the session records to allow the billing center to correctly associate the RST subscriber with the call forwarding activation call.

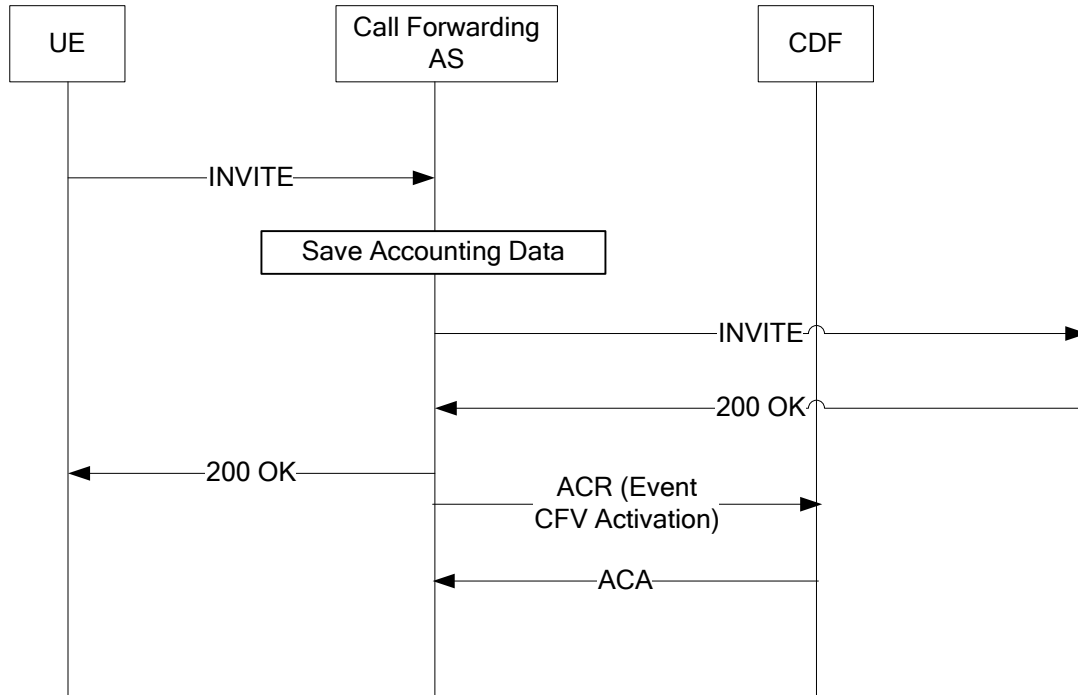

Figure 4 - Call Forward Activation with a User-Provided Address

6.2.1.2 Call Forwarding Don't Answer

Call forwarding don't answer (CFDA) is a feature that allows forwarding of all unanswered calls to the subscriber's public identity to another location. The forward-to address can be provided by the subscriber to the network operator through a non-signaling mechanism. With CFDA the forwarding happens after a pre-provisioned timeout if the forwarded public identity has not answered the call.

6.2.1.2.1 Accounting Procedures

The accounting procedures for Call Forwarding Don't Answer are the same as for Call Forwarding Variable session establishment. The CFDA AS MUST follow the procedures in Section 6.2.1.1.1.1.

6.2.1.3 Call Forwarding on Busy

Call forwarding busy line (CFBL) is a feature that allows a subscriber to activate forwarding of all calls to the subscriber's public identity to another location when the call is received while the subscriber is not capable of receiving another incoming call. The forward-to address is provided by the network operator, though the subscriber may request a particular forward-to address. With CFBL, the forwarding happens immediately upon detection that the public identity cannot receive the call and the forwarded public identity has no opportunity to answer the call prior to the forwarding.

6.2.1.3.1 Accounting Procedures

The accounting procedures for Call Forwarding on Busy are the same as for Call Forwarding Variable session establishment. The CFBL AS MUST follow the procedures in Section 6.2.1.1.1.1.

6.2.1.4 Call Forwarding Selective Call Forwarding

Selective Call Forwarding (SCF) is an incoming call management feature that allows customers to define a special list of addresses and a remote address. Incoming calls that are on the list will be forwarded to the remote address. With SCF, the forwarding happens immediately and the forwarded public identity has no opportunity to answer the call prior to the forwarding.

6.2.1.4.1 Accounting Procedures

The accounting procedures for Call Forwarding Selective Call Forwarding are the same as for Call Forwarding Variable session establishment. The CFBL AS MUST follow the procedures in Section 6.2.1.1.1.1.

6.2.1.5 Remote Activation of Call Forwarding

The remote activation of call forwarding feature (RACF) allows a subscriber who also subscribes to the call forwarding variable to control CFV for one of his PacketCable UEs from another location (i.e., not at the UE being forwarded). In order to prevent unauthorized forwarding, the subscriber is required to provide a PIN or password when activating or deactivating RACF. PIN numbers can be specified by the service provider. The service provider may also allow the subscriber to create or modify his PIN numbers using the SPP feature.

6.2.1.5.1 Accounting Procedures

6.2.1.5.1.1 CFV Activation with User Provided Address

The RACF AS MUST generate an ACR Event when it sends the BYE upon completion of the activation of CFV. The RACF AS MUST set the Role-of-Node AVP to origination. The RACF AS MUST set the Server-Role AVP to Remote Activation of Call Forwarding, the Session-Type to Activation, and the RST-Subscriber-ID to the IMPU of the forwarding party in the ACR Event.

The RACF AS MUST set the SIP-Request-Timestamp to the time when it sent the BYE.

6.2.1.5.1.2 CFV Activation to a Fixed Number

The RACF AS MUST generate an ACR Event when it sends the BYE upon completion of the activation of CFV. The RACF AS MUST set the Role-of-Node AVP to origination. The RACF AS MUST set the Server-Role AVP to Remote Activation of Call Forwarding, the Session-Type to Activation, and the RST-Subscriber-ID to the IMPU of the forwarding party in the ACR Event.

The RACF AS MUST set the SIP-Request-Timestamp to the time when it sent the BYE.

6.2.1.5.1.3 CFV Deactivation

The RACF AS MUST generate an ACR Event when it sends the BYE upon completion of the deactivation of CFV. The RACF AS MUST set the Role-of-Node AVP to origination. The RACF AS MUST set the Server-Role AVP to Remote Activation of Call Forwarding, the Session-Type to De-Activation, and the RST-Subscriber-ID to the IMPU of the forwarding party in the ACR Event.

The RACF AS MUST set the SIP-Request-Timestamp to the time when it sends the BYE.

6.2.1.5.2 DIAMETER Message Flows

Figure 5 shows the Diameter transactions that are required between participating RACF Application Server and CDF for Remote Activation of Call Forwarding. In this case, the RACF Application Server receives an INVITE, and connects an IVR into the call. The results of the IVR interactions determines the type of Call Forward activation or de-activation that is being executed. When the RACF Application Server terminates the session with a BYE, it generates an accounting event that indicates the type of Call Forwarding action that occurred.

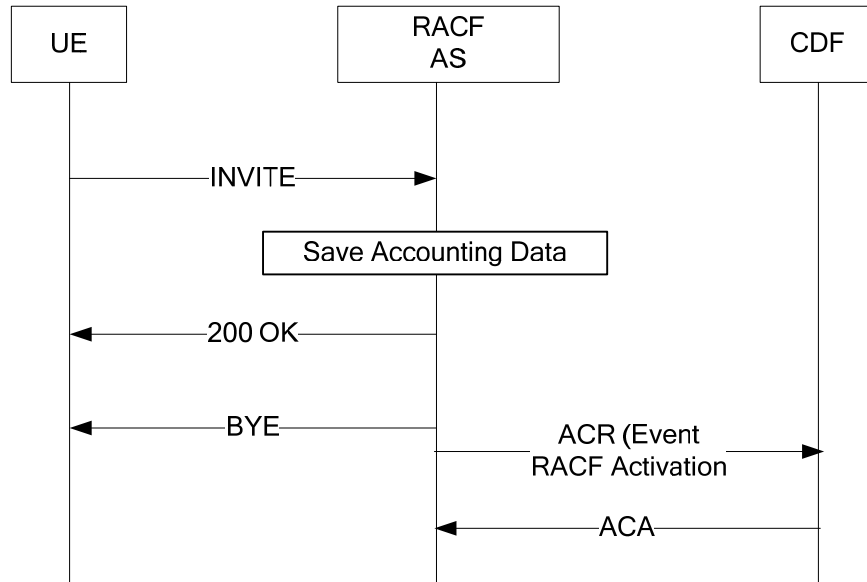

Figure 5 - Remote Activation of Call Forwarding

6.2.1.6 Call Forwarding to Voice Mail

Call forwarding to voice mail is achieved by the network operator provisioning the CFDA and CFBL features with a forward-to address of the voice mail system.

6.2.1.6.1 Accounting Procedures

When forwarding the call due to a busy line condition, the CF AS MUST follow the procedures as defined in Section 6.2.1.2.

When forwarding the call due to a don't answer condition, the CF AS MUST follow the procedures as defined in Section 6.2.1.3.

6.2.2 Call Blocking

6.2.2.1 Outbound Call Blocking

Outbound Call Blocking (OCB) prevents a UE from making calls to specific public identities, as defined in [RSTF]. Service providers typically offer this feature as one or more named outbound call blocking services. Examples include International Call Blocking, Local Directory Assistance Call Blocking, Long Distance Directory Assistance Call Blocking, 900/976 Call Blocking, and Toll Call Blocking.

The OCB AS may support an override PIN option. It does this by including an override PIN announcement in the early media session. The caller entered override PIN is forwarded to the OCB AS per the method negotiated in the early media session SDP offer-answer exchange. If the override PIN is authenticated, the OCB AS forwards the INVITE to the destination Public Identity. If the PIN override authentication fails, the OCB AS announces the authentication failure and terminates the early media session by sending a Forbidden (403) response.

If the OCB AS does not support the override PIN option, the OCB AS sends a Forbidden (403) response after announcing the call has been blocked. The Forbidden (403) response and acknowledgement end the early media session.

6.2.2.1.1 *Accounting Procedures*

Outbound Call Blocking takes place at the OCB AS. The accounting procedures at the OCB AS are described below.

When a call is blocked by the OCB AS, the OCB AS MUST generate an ACR Event and set the Server-Role to OCB and Session-Type to CALL BLOCK. The OCB AS MUST set the SIP-Response-Timestamp to the time the Forbidden (403) response was transmitted. The OCB AS MUST set the Role-of-Node AVP to origination.

If the PIN override is accepted by an OCB AS, the call is allowed and the OCB AS MUST generate an ACR Event and set the Server-Role to OCB and Session-Type to CALL BLOCK OVERRIDE. The OCB AS MUST set the SIP-Request-Timestamp to the time the INVITE was forwarded. The OCB AS MUST set the Role-of-Node AVP to origination.

If OCB is disabled (via provisioning), the call is allowed and the OCB AS MUST generate an ACR Event and set the Server-Role to OCB and Session-Type to CALL BLOCK DISABLED. The OCB AS MUST set the SIP-Request-Timestamp to the time the INVITE was forwarded. The OCB AS MUST set the Role-of-Node AVP to origination.

If the PIN override fails to authenticate, the call is blocked and the OCB AS MUST generate an ACR Event and set the Server-Role to OCB and Session-Type to CALL BLOCK. The OCB AS MUST set the SIP-Response-Timestamp to the time the Forbidden (403) response was transmitted. The OCB AS MUST set the Role-of-Node AVP to origination.

If the OCB is not configured to support the optional PIN override capability, the call is blocked and the OCB AS MUST generate an ACR Event and set the Server-Role to OCB and Session-Type to CALL BLOCK. The OCB AS MUST set the SIP-Response-Timestamp to the time the Forbidden (403) response was transmitted. The OCB AS MUST set the Role-of-Node AVP to origination.

No accounting is required when the OCB feature is subscribed via normal operator provisioning or via subscriber self-provisioning via a web portal.

No accounting is required when the OCB override PIN is changed.

6.2.2.1.2 DIAMETER Message Flows

Outbound Call Blocking takes place at the OCB AS. Normal S-CSCF accounting triggers apply.

Example call flows for Outbound Call Blocking are shown below. They are the OCB call flows from the RSTF specification [RSTF] with the OCB AS-generated accounting messages shown.

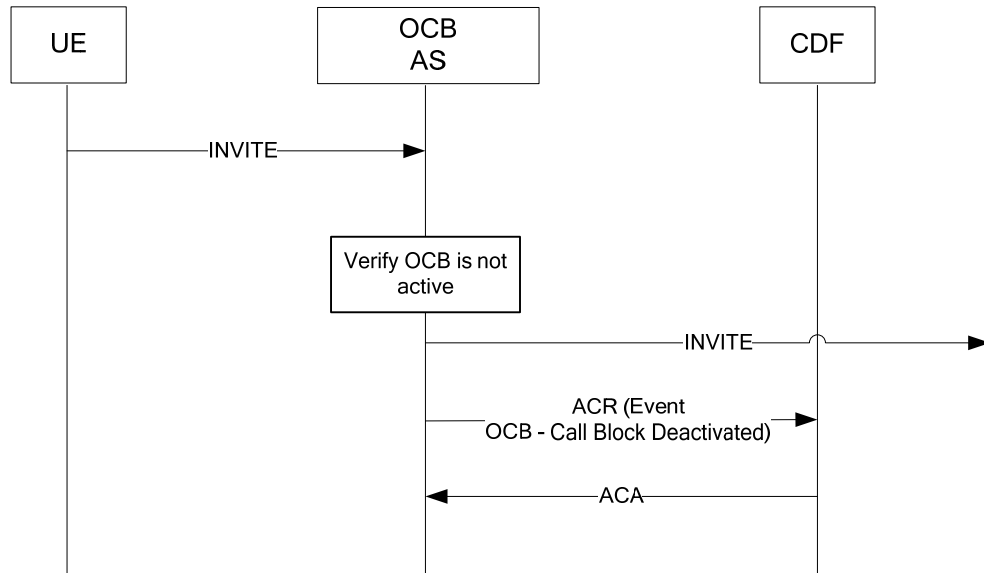

Figure 6 - Outbound Call Blocking (OCB) - Feature Deactivated

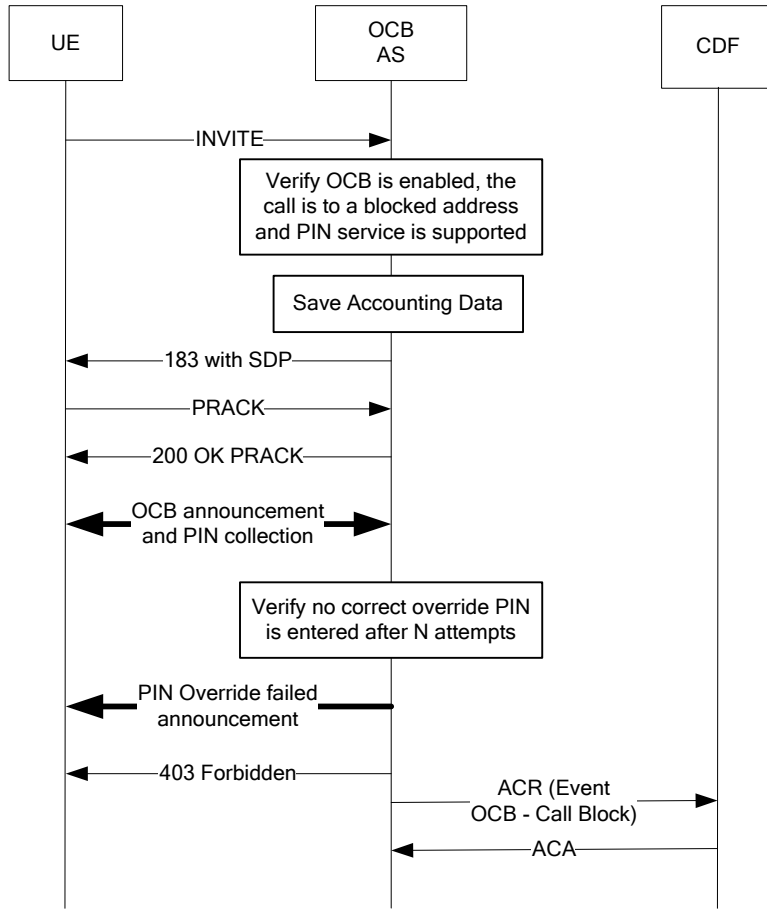

Figure 7 - OCB Invalid Override PIN

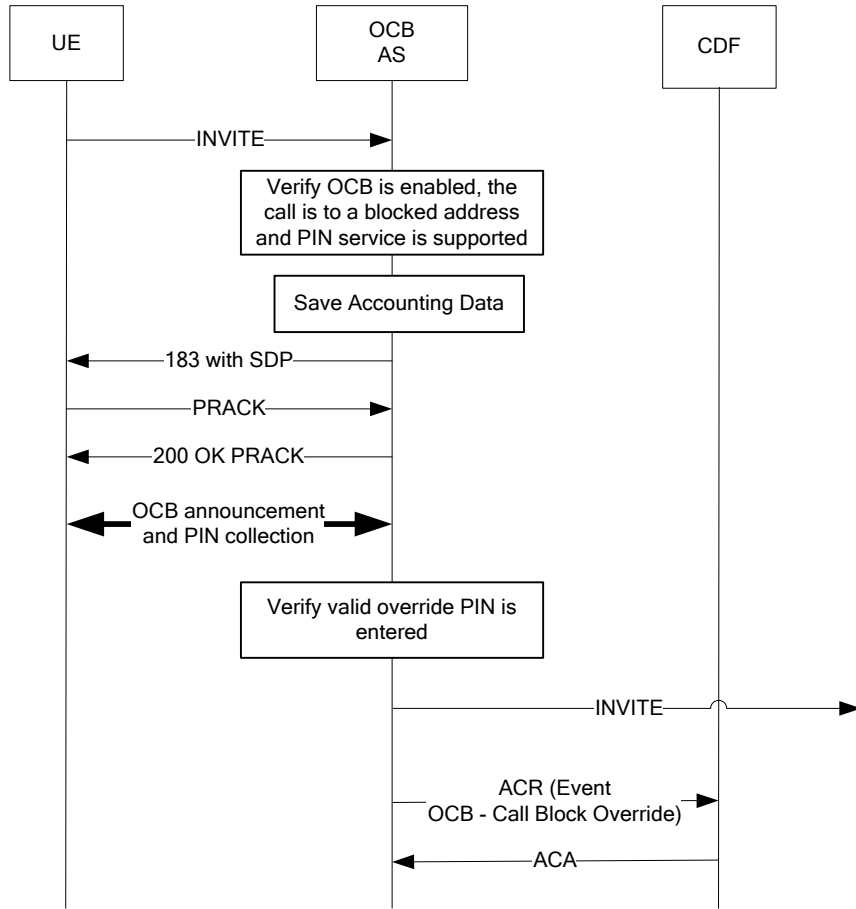

Figure 8 - OCB - Valid Override PIN

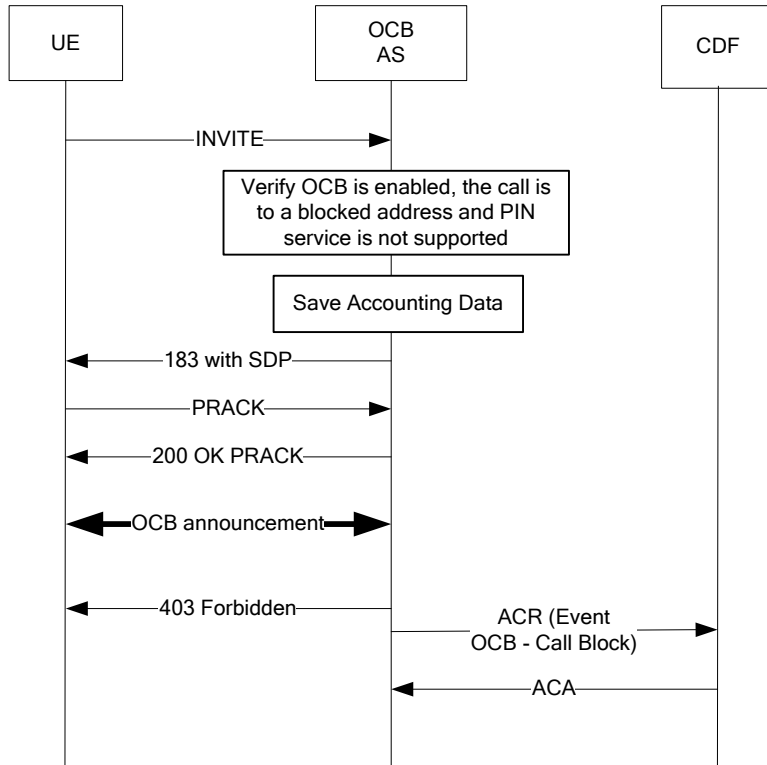

Figure 9 - OCB Override PIN Service Not Enabled

6.2.2.2 Collect Call Blocking

Collect Call Blocking prevents termination of a collect call to the subscriber's public identity as defined in [RSTF]. A blocked caller receives treatment indicating the subscriber declines to accept the call.

Collect Call Blocking is a network-based feature relying on LIDB (Line Identification Database) for feature status.

The execution of this feature depends on operator interaction with a database external to the PacketCable network. The typical use is as follows:

- A subscriber calls an operator to place a collect call;
- The operator locates the number to call in the LIDB, to determine if the call is possible;
- If the call is possible, the operator places it; otherwise, the operator informs the subscriber the call is blocked.

6.2.2.2.1 Accounting Procedures

The call is blocked at the operator service in the PSTN before it reaches the PacketCable network, requiring no resources from the PacketCable network.

This feature has no subscriber-visible activation/deactivation functionality.

6.2.2.3 Solicitor Call Blocking

Solicitor Blocking provides an IVR screen between incoming callers and the subscriber. There are two versions of this feature as defined in [RSTF].

In the first version, the incoming caller is connected to IVR and plays a greeting asking the caller to press a key to be connected to the subscriber, thereby acknowledging the caller is not a solicitor and connecting the caller to the subscriber.

In the second version, the feature application server prompts the caller for a name (greeting) to play to the subscriber. The feature application server then calls the subscriber, plays the greeting, and offers a menu of choices for handling the call. The subscriber then selects or rejects the call based on an IVR menu of choices.

In both versions of the feature there is a subscriber-specified caller acceptance list of numbers that the subscriber chooses to allow without screening.

Solicitor Blocking is dependent upon the Screening List Editing (SLE) feature to maintain an SCB caller list of numbers that will bypass the screening. A customer can initiate procedures for modifying the white list by going off-hook, receiving a dial-tone, and dialing the Solicitor Blocking access code. Each code should provide the customer with access to the same set of Solicitor Blocking capabilities.

6.2.2.3.1 Accounting Procedures

Solicitor Call Blocking (SCB) takes place at the SCB AS. The accounting procedures at the SCB AS are described below.

If the calling party does not leave a greeting, the call is blocked and the SCB AS MUST generate an ACR Event, including the Server-Role set to SCB, Session-Type set to CALL BLOCK, and the SIP-Response-Timestamp AVP set to the time the 480 final response was transmitted. The SCB AS MUST set the Role-of-Node AVP to termination.

If the called party does not accept the call, the call is blocked and the SCB AS MUST generate an ACR Event, including the Server-Role set to OCB, the Session-Type set to CALL BLOCK and the SIP-Response-Timestamp AVP set to the time the 480 final response was transmitted. The SCB AS MUST set the Role-of-Node AVP to termination.

If the called party accepts the call, the SCB AS MUST generate an ACR Event including the Server-Role set to OCB, CB-Session-Type set to CALL BLOCK OVERRIDE, and the SIP-Request-Timestamp AVP set to the time the INVITE was forwarded. The SCB AS MUST set the Role-of-Node AVP to termination.

Solicitor Blocking is dependent upon the Screening List Editing (SLE) feature to maintain an SCB caller list of numbers that will bypass the screening process. If the calling party is in the called party's SCB caller list, the call is allowed and the SCB AS MUST generate an ACR Event, including the Server-Role set to OCB, CB-Session-Type set to CALL BLOCK OVERRIDE, and the SIP-Request-Timestamp AVP containing the time the INVITE was forwarded. The SCB AS MUST set the Role-of-Node AVP to termination.

6.2.2.3.2 DIAMETER Message Flows

Solicitor Call Blocking takes place at the SCB AS. Normal S-CSCF accounting triggers apply.

Example call flows for Solicitor Call Blocking are shown below. They are the OCB call flows from the RST specification [RSTF] with the SCB AS generated accounting messages shown.

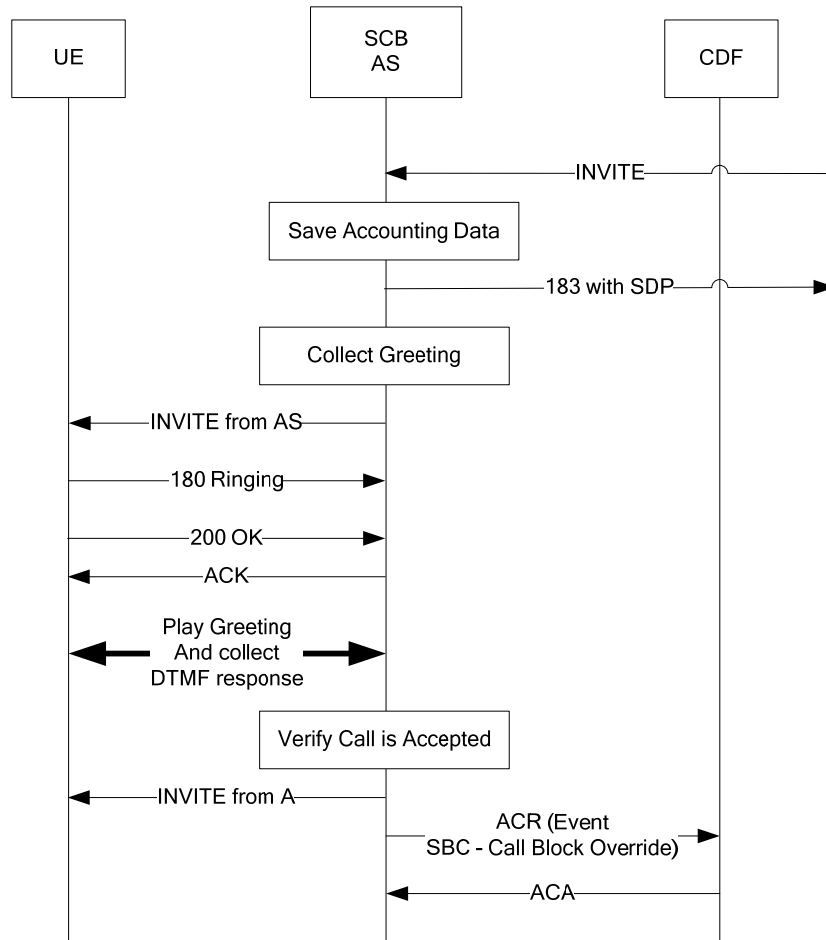

Figure 10 - SCB - Called Party Accepts

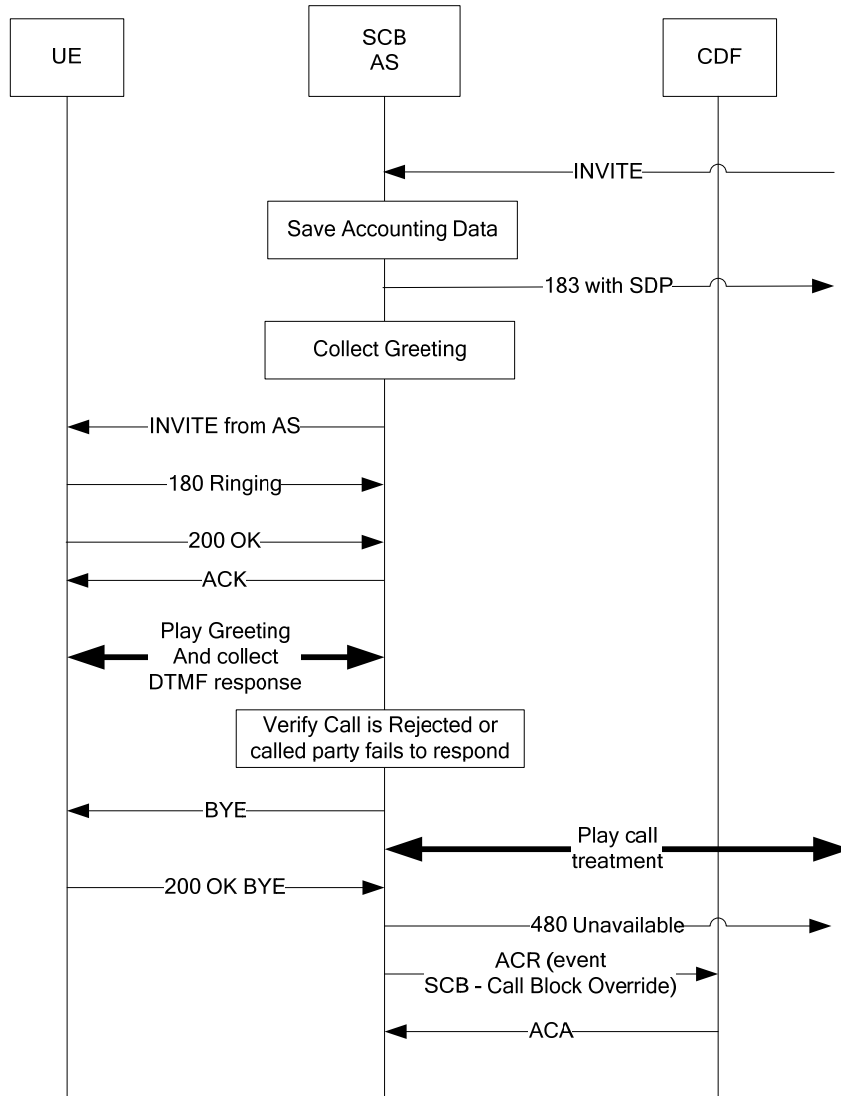

Figure 11 - SCB - Called Party Rejects or Fails to Respond to IVR

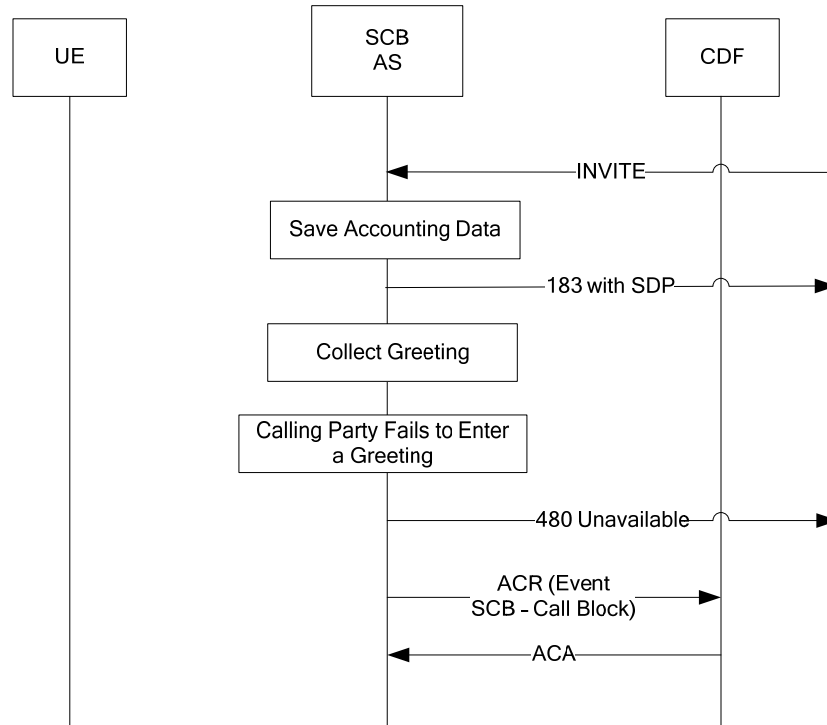

Figure 12 - SCB - Calling Party Fails to Enter a Greeting

6.2.3 Call Transfer

Call Transfer occurs when an RST subscriber who is in a stable call, flashes, calls a third party and hangs up the phone, either after talking to the third party, or while the call to the third party is still being established. The transfer is initiated when the UE sends a REFER that gets forwarded by its serving S-CSCF to a Call Transfer Application Server. The Call Transfer Application Server is in the flow of the session transfer INVITE transaction, but does not receive subsequent transactions associated with the transfer session. Before the transfer, there is a call between the RST subscriber (party B) and some other user (party A). Standard accounting records will be created for the A – B session. There may also be a consultative session between the transferor (party B) and the transfer to user (party C). If so, standard accounting records will be created for the B – C session. When the transfer session between A and C is established, standard accounting records will be created for the A – C session. To allow proper billing, the Call Transfer Application Server needs to generate an accounting record that indicates a transfer has occurred that includes information on the transferor, the transferee, and the transfer-to party, the original call sessions, including the B – C session if one is established, and the final transfer session. This will allow the billing center to generate the correct start and stop times for the calls.

Note: For a call transfer, the following could be used for the start and stop times by the billing center to calculate charges:

- A-B start time is the timestamp in the ACR Start sent by the S-CSCF when the 200 OK was sent or received for the original call.
- B-C start time is either the timestamp in the ACR Start sent by the S-CSCF when the 200 OK is received from C for the consultative leg (original B-C call) for the transfer call (A-C call).
- A-B and B-C stop timestamp in the ACR Stop sent by the S-CSCF when is the time that the BYE is sent for the A-C call.

Normally, the billing center would use the ICID to correlate accounting records. When the UE generates the REFER message that is received by the Call Transfer Application Server, the UE does not know the ICID(s), only the Call-ID(s) that are included in the REFER message. Thus, the Call Transfer Application Server can generate accounting record(s) that contains the original session Call-ID, the consultative session Call-ID, if applicable, and the transfer session ICID. Standard accounting records that are generated by IMS include both the Call-ID as well as the ICID. This is expected to allow a billing center to do the necessary correlation of records.

6.2.3.1 Accounting Procedures

Call Transfer accounting procedures need to address accounting procedures related to three parties: the transferor (always an RST subscriber), transferee (may be an RST subscriber), and the transfer-to party (may be an RST subscriber).

6.2.3.1.1 Successful Call Transfer Establishment – Transferor Accounting

Call Transfer is managed by the Call Transfer AS in response to a REFER from the transferor. The accounting procedures are described below.

Two accounting events occur as a result of the SIP signaling. The SIP 202 ACCEPTED response to the REFER and the SIP 200 OK response to the transfer session INVITE trigger the accounting sequence in the Call Transfer Application Server. If the Call Transfer Application Server rejects the REFER with an error code or the transfer-to party rejects the transfer session, the Call Transfer Application Server generates accounting events to record the error. The Call Transfer AS MUST include the same Call Transfer feature specific information for both a successful Call Transfer and the error case.

The Call Transfer Application Server MUST generate an ACR Event when it receives the 202 ACCEPTED or an error response for the REFER that is forwarded to the transferee. The Call Transfer AS MUST include the AVPs in the table below with the values specified.

Table 1 - Call Transfer ACR Event AVPs for 202 Accepted

AVP	Value	Informative Notes
Role-of-Node	origination	None
Server-Role	call transfer	None
Session-Type	REFER	None
RST-Subscriber-ID	IMPU of the RST subscriber requesting the transfer	None
Target	value of the Target header field	The Target header includes the SIP Call-ID for the original call (A – B Call).
Refer-To	value of the Refer-to header field	The Refer-to header contains a Replaces header with a Call-ID parameter. This is the SIP Call-ID for the call to the transfer-to party (B – C call).
SIP-Response-Timestamp	the time that Call Transfer AS received the 202 or an error in response to the REFER	None

In the case where an error response was received, the Call Transfer AS MUST set the Cause-Code (AVP 861) indicating the response code received by the Call Transfer AS.

The Call Transfer Application Server MUST generate an ACR Event when it receives the 200 OK or error response to the INVITE for the transfer call. The Call Transfer AS MUST include the AVPs in the table below with the values specified.

Table 2 - Call Transfer ACR Event AVPs for 200 OK

AVP	Value	Informative Notes
Role-of-Node	origination	None
Server-Role	call transfer	None
Session-Type	session establishment	None
RST-Subscriber-ID	IMPU of the RST subscriber requesting the transfer	None
Target	value of the Target header field from previous REFER message	The Target header includes the SIP Call-ID for the original call (A – B Call).
Refer-To	value of the Refer-to header field from previous REFER message	The Refer-to header contains a Replaces header with a Call-ID parameter. This is the SIP Call-ID for the call to the transfer-to party (B – C call).
Transfer-Session-Call-ID	Call-ID parameter in the Call-ID header of the INVITE	This is the SIP Call-ID for the transfer session (A – C call).
SIP-Response-Timestamp	the time that Call Transfer AS received the 200 OK or an error in response to the INVITE	None

In the case where an error response was received, the Call Transfer AS MUST set the Cause-Code (AVP 861) indicating the response code received by the Call Transfer AS.

6.2.3.1.2 Successful Call Transfer Establishment - Transferee Accounting

In addition to the accounting records for the transferor (party B), accounting records for the transferee (party A) need to be considered. Since the call transfer involves replacing the original call with a new SIP session, care needs to be taken to ensure the transferee (party A) is correctly billed. Accounting records for party A should enable the billing center to ensure that A is billed at the original A – B call rate. At some time after the initial call has been setup, the transferee (party A) receives a REFER that causes it to initiate a call to the Call Transfer Application Server.

Note: The ACR event for the REFER is being extended as specified in [ACCT]. This will allow the billing center to bill the transfer call (A - C Call) as a continuation of the A - B call, since the REFER ACR event will contain the A-B Call-ID in the Target AVP and the CT-AS info, which is the target for the A - C Call, in the Refer-to AVP. To ensure that this is a transfer, the billing center may test to see that the A-CT-AS INVITE ACR start timestamp is within some limit of the REFER ACR event timestamp (e.g., within 10 seconds).

If the transferee (party A) is in the PSTN and is connected via an MGC, there would be no signaling back to party A for the transfer call, and its billing center would only have records that show the initial call to the transferor (party B), with a start time corresponding to when the answer message from or to the transferor (party B) occurred, and with a stop time that occurs after the completion of the call to the transfer-to party (party C).

6.2.3.1.3 Successful Call Transfer Establishment – Transfer-to Party Accounting

Since the transfer-to party (party C) is the terminating side of any call leg associated with a call transfer, no special accounting activities are required for the transfer-to party.

6.2.3.2 DIAMETER Message Flows

Call Transfer accounting scenarios are shown for three parties involved in a call transfer: the transferor (always an RST subscriber), transferee (may be an RST subscriber), and transfer-to party (may be an RST subscriber).

6.2.3.2.1 Successful Call Transfer Establishment - Transferor

Figure 13 shows the Diameter transactions that are required between the Call Transfer Application Server and the CDF during a Call Transfer initiated by the transferor. The 202 Accepted for the transfer REFER and the 200 OK for the transfer INVITE trigger accounting action in the Call Transfer AS. The Call Transfer AS does not remain in the signaling path after the transfer INVITE transaction completes.

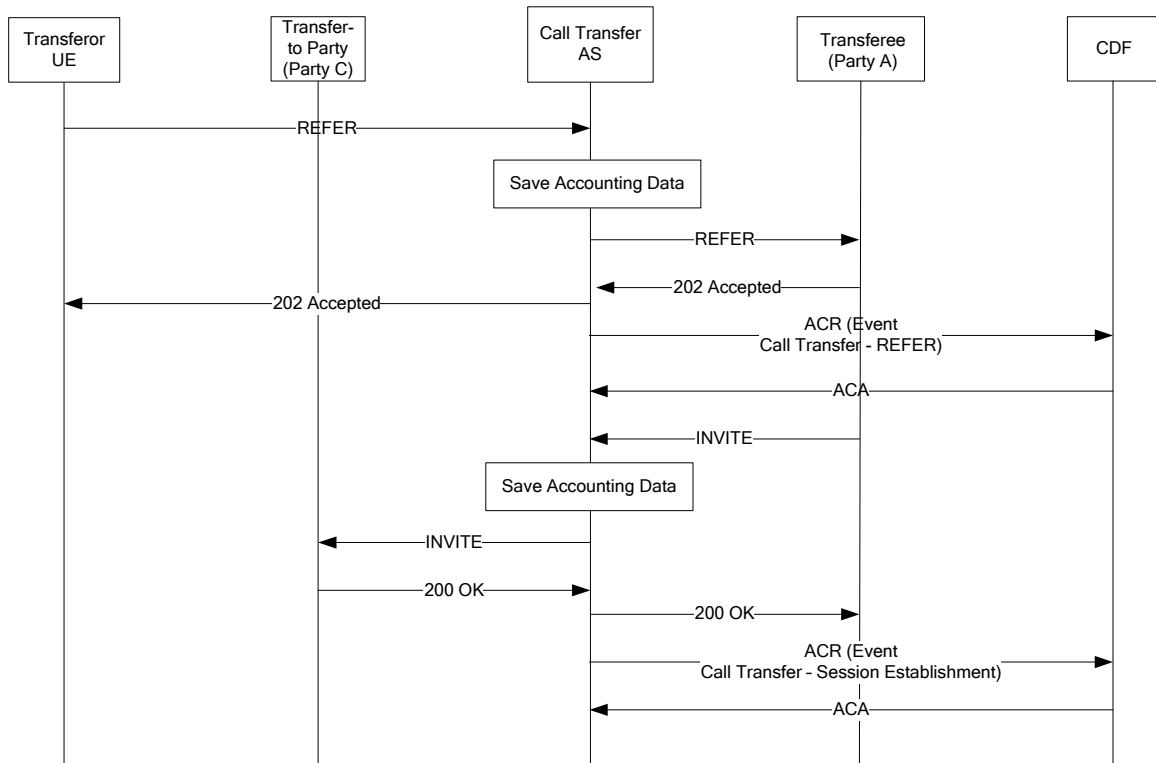

Figure 13 - Call Transfer Establishment

6.2.4 Auto Recall (for Anonymous Calls Only)

The Automatic Recall (AR) feature allows a UE to automatically return a call to the last calling address (the target address is the P-Asserted-ID of the caller) that sent an INVITE to this UE, whether the INVITE was answered by this UE or not. The AR feature should work even when the last call received at the UE did not supply a caller ID. The AR feature invocation has the following two variations:

1. Non-Anonymous AR: The caller ID of the last received call at an AR requesting UE is known, and the AR can be placed at the target address directly by either entering the last caller ID or pushing a button on the requesting

UE. This case of AR feature invocation does not require the use of an AS and thus becomes of a case of basic session establishment call, requiring no event-related accounting records to be created.

2. Anonymous AR: The public identity of last caller is not known to (not supplied at) the AR requesting UE, and the AR feature invocation becomes that of an "Anonymous AR" feature and will involve the intervention of an AR Application Server (AR AS). Consequently, the accounting procedure for this "Anonymous AR" feature will include a generation of event-related accounting data, due to the intervention of the AR AS and its associated actions, resulting in a number of possible accounting scenarios.

This section contains accounting specifications for the case of "Anonymous AR." It should be clear that no accounting is required when the AR is subscribed by the subscriber's self-provisioning action via a web portal.

6.2.4.1 Accounting Procedures

The AR AS will search its network-based call logs with P-Asserted-IDs for the last terminating call to the AR requesting UE and to retrieve the identity of the anonymous target UE matching the call ID provided by the requesting UE. Upon finding the identity, the AR AS replaces the call ID in the INVITE with the IMPU and sends the INVITE back to the S-CSCF to be delivered to the target UE. At this juncture, the AR AS generates an accounting request, ACR Event, indicating a successful target UE identification event for the anonymous AR feature invocation.

If the "INVITE" request to the target UE is returned with a response of "Busy," the requesting UE will send a "SUBSCRIBE" message (via S-CSCF to AR AS to S-CSCF) to the target UE to monitor its Busy/Idle state. Upon sending the SUBSCRIBE message, the AR AS generates another accounting record, an ACR Event, indicating another successful event of associating the anonymous last call ID to the IMPU of the target UE. If while subscribed to the target UEs Busy/Idle state, the user chooses to de-activate the AR feature before the "AR Feature Timer" expires, the requesting UE sends an INVITE message with a request URI containing the AR deactivation VSC and the call ID to the AR AS. Upon receiving this deactivation INVITE message, the AR AS identifies the most recent AR call activation request and sends a SUBSCRIBE message with Expires Header = 0 to the target UE, which cancels the subscription.

If the number of simultaneously SUBSCRIBE messages, queued at the target UE, has already reached a provisioned threshold, the newly arrived SUBSCRIBE message is responded with a "486 Busy Here" or "600 Busy Everywhere" response, and the target UE rejects the SUBSCRIBE message request. Then the Requesting UEs AR-ACTIVATE procedure fails the AC request by playing an error announcement (either a voice or tone announcement) to the caller according to the procedures specified in [RSTF].

If the target UE responds to the SUBSCRIBE message by a "NOTIFY" of a change in its state from "Busy" to "Idle," and the AR feature activation time has not expired, another INVITE request will be sent by the requesting UE to the target UE, to be responded with a "180 Ringing" message. Otherwise, the SUBSCRIBE request will persist until the AR invocation time expires.

The accounting for the AR events is not triggered until after the AR activation code is dialed, the anonymous AR feature is invoked, and the AR AS has sent the INVITE back to the S-CSCF. As a matter of procedure, every time the AR AS performs and successfully completes a function, it generates an ACR Event, including the AR-Session-Type AVP set to the corresponding AR event, and the SIP-Response-Timestamp AVP that contains the time the response to the AR AS request message was received by the AR AS. The accounting records for the AR specific message reported by the AR AS are correlated with the accounting records (reported by the P-CSCF and S-CSCF) of the basic call that follows the invocation of the anonymous AR using the same ICID.

The following seven possible outcomes, two successes, one deactivation, and four failures, may result from applying the above-described anonymous AR accounting procedure to invoke the AR feature.

6.2.4.1.1 *Successful AR Invocation*

Upon receipt of an INVITE that identifies the AR feature, the AR AS retrieves the public identity of the target UE and forwards the INVITE, resulting in either "180 Ringing" or "200 OK" message from the target UE. If the target UE rings, then the AR feature invocation is complete. The AR AS MUST generate an ACR Event upon receipt of either a 180 or 200 message to the forwarded INVITE. The AR AS MUST set the Role-of-Node to originator, the Server-Role to Auto Recall, and the Session-Type to success. The AR AS MUST set the SIP-Response-Timestamp in the ACR Event to the time when it received either the 180 or the 200 response to the INVITE.

6.2.4.1.2 *Delayed Successful AR*

If the target UE responds to the initial INVITE with a "486 busy" or "600 busy everywhere" SIP response message, the AR AS MUST generate an ACR Event. The AR AS MUST set the Role-of-Node to originator, the Server-Role to Auto Recall, and the Session-Type to delay success. The AR AS MUST set the SIP-Response-Timestamp in the ACR Event to the time when it received either the 486 or the 600 response to the INVITE.

As a result of the error response, the requesting UE will send a SUBSCRIBE message to the AR AS to subscribe to the target UEs state. If configured, the AR AS MUST generate an ACR Event upon receipt of the 200 OK from the target UE to the SUBSCRIBE and the resulting NOTIFY.

Upon notification that the target UE is now idle, the requesting UE will send another INVITE to the AR AS. If the INVITE to the Target UE is responded by a "180 Ringing" or "200 OK," then the AR feature invocation is complete with a delay. In this case the AR AS MUST generate an ACR Event upon receipt of either a 180 or a 200 message to the forwarded INVITE. The AR AS MUST set the Role-of-Node to originator, the Server-Role to Auto Recall, and the Session-Type to success. The AR AS MUST set the SIP-Response-Timestamp in the ACR Event to the time when it received either the 180 or the 200 response to the INVITE.

6.2.4.1.3 *Deactivation of Successful AR Invocation*

Upon receipt of an INVITE message with request URI containing the AR deactivation VSC and the call ID, the AR AS identifies the most recent AR call activation request and sends a SUBSCRIBE message with Expires Header = 0 to the target UE, which cancels the subscription. The AR AS MUST generate an ACR Event upon receipt of a response to the SUBSCRIBE (either positive or negative). The AR AS MUST set the Role-of-Node to originator, the Server-Role to Auto Recall, and the Session-Type to de-activation. The AR AS MUST set the SIP-Response-Timestamp in the ACR Event to the time when it received the response to the SUBSCRIBE.

6.2.4.1.4 *Unsuccessful due to Time Expiration*

If the target UE responds to the initial INVITE with a "486 busy" or "600 busy everywhere" SIP response message, the AR AS MUST generate an ACR Event. The AR AS MUST set the Role-of-Node to originator, the Server-Role to Auto Recall, and the Session-Type to delay success. The AR AS MUST set the SIP-Response-Timestamp in the ACR Event to the time when it received either the 486 or the 600 response to the forwarded INVITE.

If the SUBSCRIBE to the target UE expires before receiving notification of a change in state, the AR AS MAY receive a NOTIFY indicating the termination of the subscription. If the AR AS receives such a notification and is configured to generate accounting events for NOTIFY messages, the AR AS MUST generate an ACR Event. The AR AS MUST set the Role-of-Node to originator, the Server-Role to Auto Recall, and the Session-Type to Failure_Timeout. Given that no additional SIP signaling results from the timeout of the subscription, the AR AS MUST NOT include the time_stamps AVP in the ACR Event and simply uses the Origination Timestamp as defined by the DIAMETER header.

6.2.4.1.5 *Unsuccessful due to SUBSCRIBE Limitation at the Target UE*

If the target UE responds to the initial INVITE with a "486 busy" or "600 busy everywhere" SIP response message, the AR AS MUST generate an ACR Event. The AR AS MUST set the Role-of-Node to originator, the Server-Role

to Auto Recall, and the Session-Type to delay success. The AR AS MUST set the SIP-Response-Timestamp in the ACR Event to the time when it received either the 486 or the 600 response to the forwarded INVITE.

If the target UE responds with "480 temporarily unavailable" to the SUBSCRIBE, the AR AS MUST generate ACR Event. The AR AS MUST set the Role-of-Node to originator, the Server-Role to Automatic Recall, and the Session-Type to Failure_SUBS_Limit. The AR AS MUST set the SIP-Response-Timestamp to the time when it received the 480 to the SUBSCRIBE.

6.2.4.1.6 Unsuccessful due to No Target UE Dialog

If the target UE does not support the dialog event package, it will respond to SUBSCRIBE requests with a "489 Bad Event." The AR AS MUST generate an ACR Event upon receipt of the 489 response. The AR AS MUST set the Role-of-Node to originator, the Server-Role to Automatic Recall, and the AR-Session-Type to Failure_Dialog. The AR AS MUST set the SIP-Response-Timestamp to the time when it received the 489 to the INVITE.

6.2.4.1.7 Unsuccessful due to Unidentified Target UE

When the AR AS fails to identify the anonymous target public identity of the target UE, it rejects the INVITE message from the requesting UE by sending a "489 Bad Event" response message. The AR AS MUST generate an ACR Event upon sending of the 489 response. The AR AS MUST set the Role-of-Node to originator, the Server-Role to Automatic Recall, and the Session-Type to Failure_Identity. The AR AS MUST set the SIP-Response-Timestamp AVP to the time when it received the "489 Bad Event" response to the INVITE.

6.2.4.2 DIAMETER Message Flows

This section provides diagrams detailing the generic flow diagram and adding the accounting related actions required by the AR AS for each case of success and failure.

6.2.4.2.1 Successful AR Invocation

Figure 14 shows a successful AR invocation that went through on the first INVITE request message from the requesting UE to the target UE. The AR AS will generate ACR Event once, and that occurs after forwarding the INVITE message to S-CSCF.

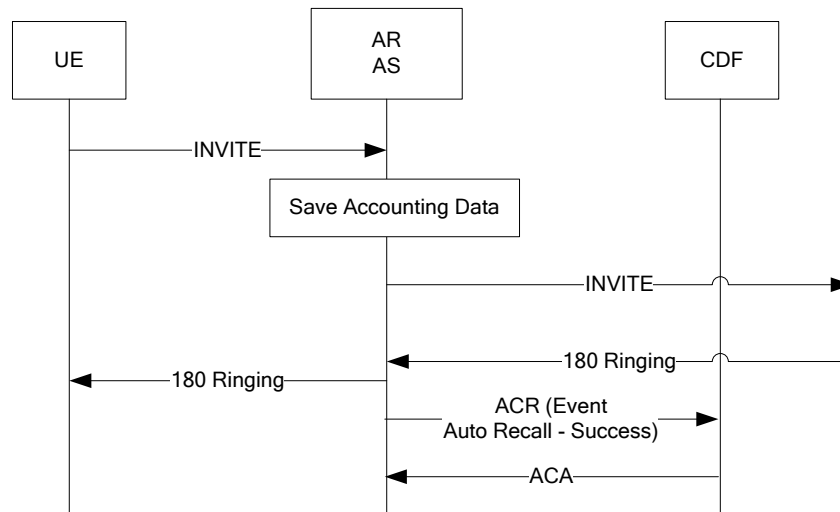

Figure 14 - Successful AR Accounting Flow Diagram

6.2.4.2.2 *Delayed Successful AR*

Figure 15 shows a successful AR invocation that was delayed by an additional request message, SUBSCRIBE to the target UEs state, sent by the requesting UE due to the target UE being busy when the first INVITE arrived. In this scenario, the AR AS issues three ACR Event request messages, after receiving the sending first INVITE, the first SUBSCRIBE, and the second INVITE, all to S-CSCF.

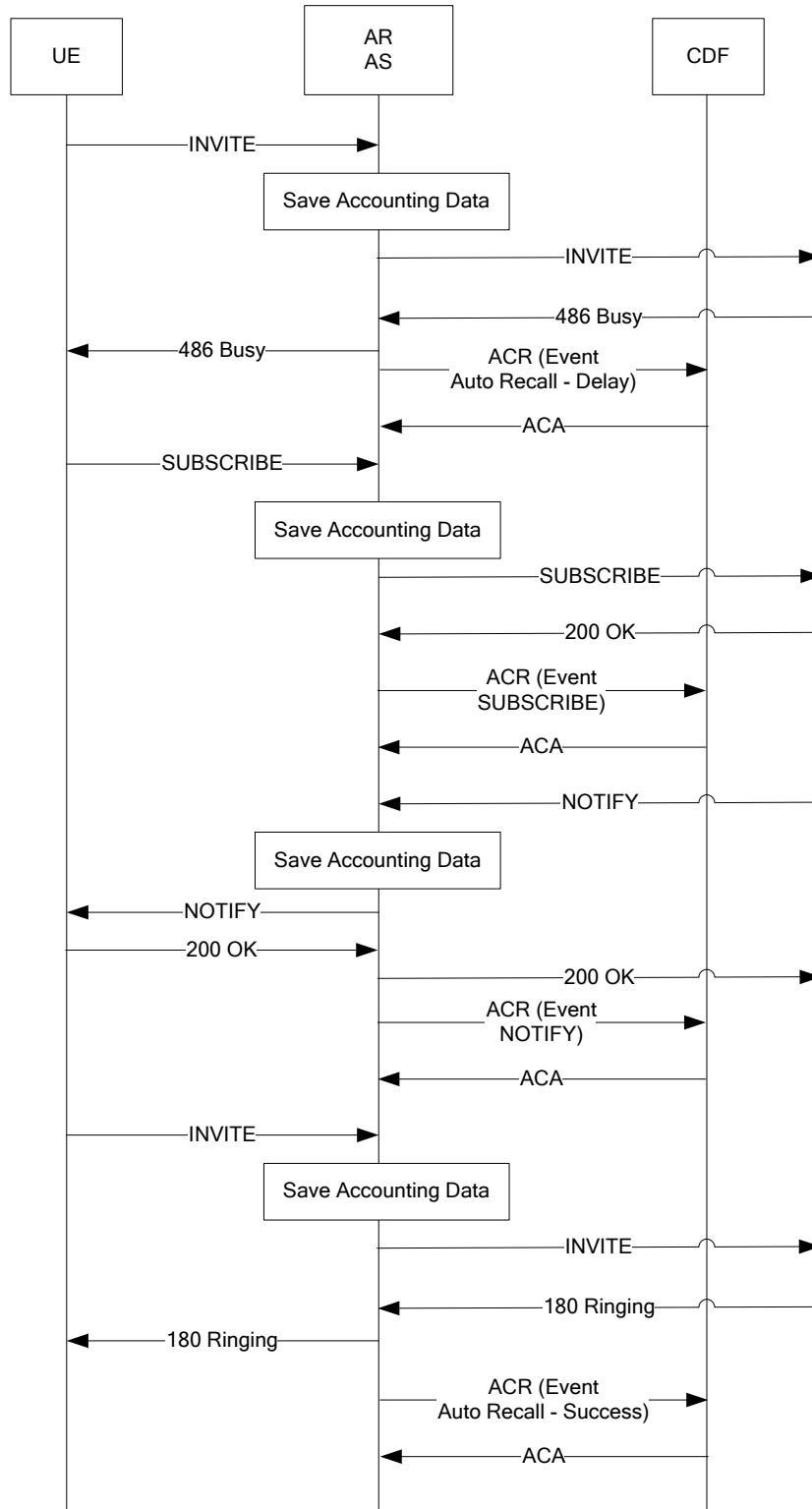

Figure 15 - Delayed Successful AR Accounting Flow Diagram

6.2.4.2.3 Unsuccessful Due to Time Expiration

Figure 16 shows a scenario of an unsuccessful AR invocation due to the expiration of the AR invocation time. For this scenario, in addition to two accounting records for the first INVITE and the first SUBSCRIBE, there will be an additional ACR Event after the second NOTIFY request is forwarded to the S-CSCF.

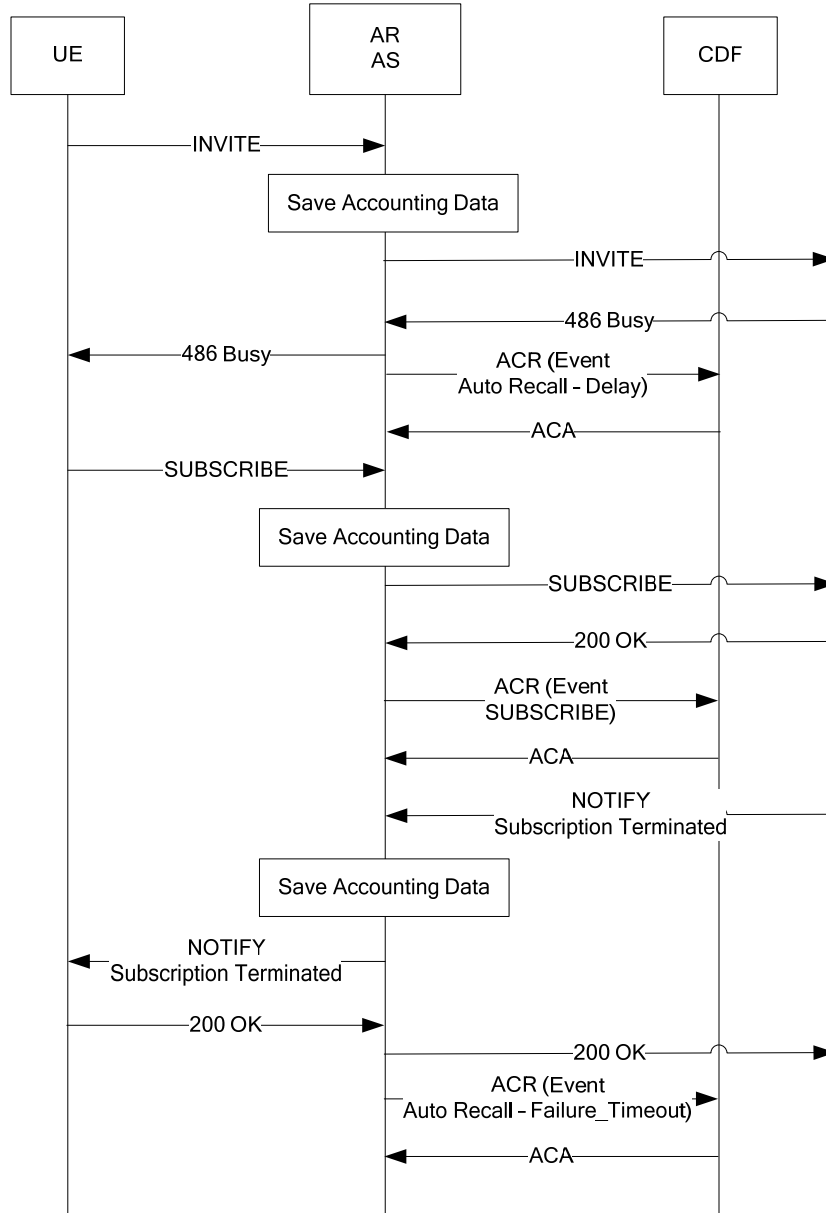

Figure 16 - Unsuccessful AR Accounting Due to Time Expiration

6.2.5 Auto Callback (for Anonymous Calls Only)

The Automatic Callback (AC) feature, as described in [RSTF], allows a UE to automatically call back the last called address (the target address that is the URI of the called party) to which the last INVITE was sent from this UE, whether the INVITE request was responded by the called party or not. The AC feature invocation has the following two variations:

1. **Non-Anonymous AC:** The public identity of the most recently called party is known. In this case, an AC feature call can be placed at the target address, directly by either entering the public identity of the last called party, or pushing a button on the requesting UE. This case of AC feature invocation becomes of a case of basic session establishment call, requiring no even-related accounting records to be created other than what is needed for the basic call accounting as addressed in Section 6.1 of this specification.
2. **Anonymous AC:** The public identity of the most recently called party is not known. This can happen when the most recently called party was the target UE of an anonymous Auto Recall (AR). In this case, the most recently called party for the AC will be an anonymous AC target party. The calling party UE locally stores the most recent call ID and the fact that the called party was anonymous.

This section contains accounting specifications for the case of "Anonymous AC." It should be clear that no accounting is required when the AC is subscribed by subscriber's self-provisioning action via a web portal.

6.2.5.1 Anonymous AC Accounting Procedures

Triggered by the S-CSCF, an AC application server (AC AS) stores in its network-based call logs the P-Asserted-Identity of the most recently made call by a UE if the called party's identity were to be kept anonymous. In other words, the most recent call was the subject of an anonymous Automatic Recall (AR).

To invoke the anonymous AC feature, the UE sends an INVITE to the AC AS with a request URI containing the AC service activation code and the call ID of the most recent call attempt made by this UE.

At this point, the "Anonymous AC" accounting procedure becomes the same as the procedure described for the "Anonymous Auto-Recall," Section 6.2.4. The Anonymous AC AS MUST follow the accounting procedures as defined in Section 6.2.4 with the exception that the Server-Role MUST be set to Auto Callback.

6.2.6 Operator Services

Operator Services allow a subscriber to verify the busy state of a line (BLV) and join an existing call on that line if that line is busy (barge-in). The subscriber connects to an operator to perform the verification by dialing 0+ the number to verify. The operator then calls the number, and if it is busy, bridges the call using a special media gateway connected to an MGC. The connection is receive-only and scrambled when verifying, and send-receive when barging in.

Billing for this service is by a dedicated billing system on the Operator Services platform external to the PacketCable network. The PacketCable network will generate normal session accounting events for inbound operator services calls. However, providing explicit accounting level details as to the type of operator service being performed is out of scope of this document.

6.2.7 COT

The Customer Originated Trace (COT) feature allows a user to initiate a call trace from the UE by dialing *57, the COT activation code. Upon dialing *57, a SIP early media session is established with the COT Application Server (AS) (i.e., the AS providing the COT feature) and its associated media server. A COT service message is played which usually describes the feature and cost, and then provides a request for a confirmation digit ("1") to initiate the trace of the last incoming call. While the COT feature could be included within a bundled feature package, it is usually charged on a single event basis since it is rarely invoked and is usually only provided as a regulatory requirement, not as a revenue-generating feature.

6.2.7.1 Accounting Procedures

The COT feature has the following two scenarios to consider:

1. The alleged malicious caller is known to the UE associated with the offended party (that is, the P-Asserted-ID of the malicious caller is available in the INVITE message and can be provided to the COT AS).
2. The alleged malicious caller is anonymous to the UE associated with the offended party (that is, the COT AS collects and provides the P-Asserted-ID of the malicious caller on the offended party's behalf).

In the first scenario, a COT AS is not required to collect the P-Asserted-ID of the malicious caller, and is only triggered when the *57 COT vertical service code is dialed.

In the second scenario, the malicious caller is unknown to the offended party's UE because he or she has elected the privacy feature, providing anonymity to untrusted SIP entities. The COT AS stores the P-Asserted-ID for all terminating calls where anonymity (privacy: id) has been requested.

In both scenarios, after the activation code (*57) is dialed, and the early media session is established to play the COT announcement, the COT feature is still not executed until the COT confirmation code is dialed. Dialing the confirmation digit initiates the accounting event. If the COT AS receives the confirmation digit and can provide call tracing data, the COT AS MUST generate an ACR Event. The COT AS MUST set the Role-of-Node to originator, and the Server-Role to COT. Given that no additional SIP signaling results from the confirmation of the COT request, the COT AS MUST NOT include the time_stamps AVP in the ACR Event and simply uses the Origination Timestamp AVP as defined by the DIAMETER header.

The COT AS MUST NOT generate an ACR Event if the call tracing data could not be collected for any reason or if the confirmation is not provided.

6.2.7.2 DIAMETER Message Flows

In both COT scenarios, the accounting is identical because only the mechanism of capturing the malicious caller identity differs. The usefulness to the COT user is identical in both scenarios; hence the accounting method and resulting charge should be identical.

Figure 17 provides a simplified call flow that summarizes the COT accounting procedures.

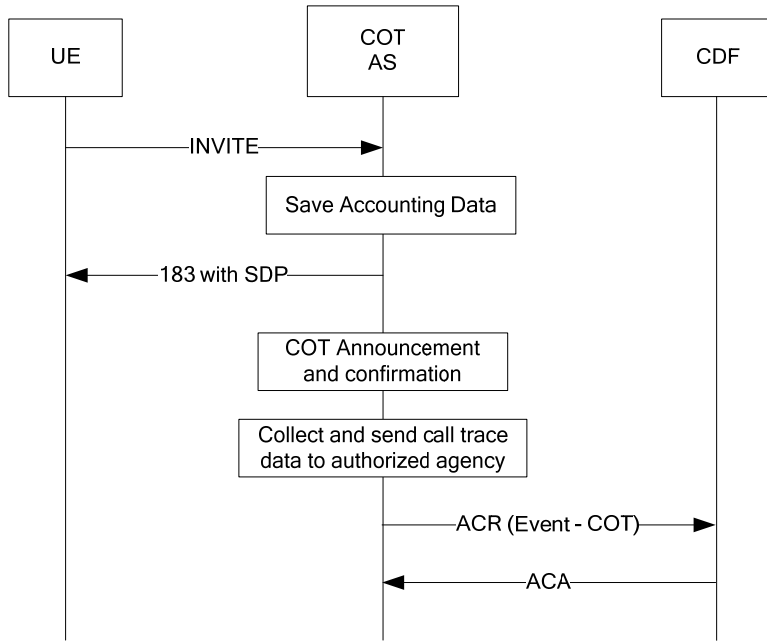

Figure 17 - COT Accounting Flow

7 DEFINITION OF ACCOUNTING INFORMATION

This section is to document any additional AVPs necessary for RST accounting.

7.1 Data Description for RST Offline Accounting

The Application Server providing RST Services generates accounting information that can be transferred from the CTF to the CDF with the Diameter accounting application. Detailed information about the usage of the Diameter accounting application is described in [TS 32.299].

7.1.1 Rf Message Contents

7.1.1.1 Summary of Offline Charging Message Formats

The RST Charging application for offline charging employs the Accounting-Request (ACR) and Accounting-Answer (ACA). The ACR can be of type start, stop, interim, or event, and includes all charging information. The ACA is just an acknowledgement of the ACR.

Table 3 describes the use of these messages for offline charging.

Table 3 - Offline Charging Messages Reference Table

Command-Name	Source	Destination	Abbreviation
Accounting-Request	RST Application Server	CDF	ACR
Accounting-Answer	CDF	RST Application Server	ACA

7.1.1.2 Structure for the Accounting Message Formats

RST offline charging uses the diameter accounting application with the two messages ACR and ACA. The request can be of type start, stop, interim, or event. The accounting request message includes all charging information and the answer is just an acknowledgement of the request message. Detailed information about the diameter offline charging application is described in [TS 32.299].

This sub clause describes the different fields used in the accounting messages.

7.1.1.2.1 Accounting-Request Message

The basic structure of a Diameter ACR message and the detailed descriptions of the fields are provided in [TS 32.299].

Section 7.2 of this document provides the extensions to the basic ACR message and the associated detailed descriptions of those fields necessary for RST accounting.

7.1.1.2.2 Accounting-Response Message

The basic structure of a Diameter ACA message and the detailed descriptions of the fields are provided in [TS 32.299].

RST accounting does not define any extensions to the ACA message.

7.2 RST Specific Parameters

7.2.1 Definition of the RST Information

The RST Information parameter used for RST accounting is provided in the Service Information parameter.

7.2.1.1 RST Information assignment for Service-Information

The components in the Service Information that are used for RST can be found in Table 4.

Table 4 - Service Information used for RST

Field	Category	Description
Service Information	O _M	This is a structured field and holds the 3GPP specific parameter as defined in [TS 32.299]. For IMS Charging the IMS Information is used.
IMS Information	O _M	This is a structured field and holds the IMS specific parameters. The details are defined in [TS 32.260].
PS Information	O _C	This is a structured field and holds PS specific parameters. The complete structure is defined in [TS 32.251].
GGSN Address	O _C	This field holds the IP-address of the GGSN that generated the GPRS Charging ID, as described in [TS 32.240].
RST Information	O _M	This is a structured field and holds the RST specific parameters. The details are defined in Section 7.2.1.2.

7.2.1.2 Definition of the RST Information

RST-specific charging information is provided within the RST Information AVP group. The detailed structure of the IMS Information can be found in Table 5.

Table 5 - Structure of the RST-Information

Field	Category	Description
Server-Role	O _M	Identifies the feature being performed by the RST Application Server
Session-Type	O _M	Type of action being performed
RST-Subscriber-ID	O _M	IMPU of RST subscriber
Call-Transfer	O _M	Call Identifiers for each leg of a transferred call

7.2.2 RST Specific AVPs

For the purpose of RST accounting, additional AVPs are used in ACR / ACA. The information is summarized in Table 6 along with the AVP flag rules.

The 3GPP-defined service information uses the value 10415 (3GPP) as the *Vendor-Id* while the RST information uses the value of 4491 (CableLabs) as the *Vendor-Id*.

Detailed descriptions of AVPs that are used specifically for RST accounting are provided in the subsections below and MUST be formatted as defined.

Table 6 - RST specific AVPs

AVP Name	AVP Code	Used in				Value Type	AVP Flag rules				
		ACR	ACA	CCR	CCA		Must	May	Should not	Must not	May Encr.
Call-Transfer	201	X	-	-	-	Grouped	V, M	P	-	-	N
Refer-To	223	X	-	-	-	UTF8String	V, M	P	-	-	N
RST-Information	224	X	-	-	-	Grouped	V, M	P	-	-	N
RST-Subscriber-ID	225	X	-	-	-	UTF8String	V, M	P	-	-	N
Server-Role	226	X	-	-	-	Enumerated	V, M	P	-	-	N
Session-Type	227	X	-	-	-	Enumerated	V, M	P	-	-	N
Target	230	X	-	-	-	UTF8String	V, M	P	-	-	N
Transfer-Session-Call-ID	232	X	-	-	-	UTF8String	V, M	P	-	-	N

7.2.2.1 Call-Transfer

The *Call-Transfer AVP* (AVP code 201) is of type Grouped. Its purpose is to allow the transmission of additional Call IDs associated with a Call Transfer.

It has the following ABNF grammar:

```

Call-Transfer ::= < AVP Header: 201 >
                [ Target ]
                [ Refer-To ]
                [ Transfer-Session-Call-ID ]
    
```

7.2.2.2 Refer-To

The *Refer-To AVP* (AVP code 223) is of type UTF8String and contains the SIP Call-ID for the transfer-to party, if a consultative session had been established (the B – C call).

7.2.2.3 RST-Information AVP

The *RST-Information AVP* (AVP code 224) is of type Grouped. Its purpose is to allow the transmission of additional RST service specific information elements.

It has the following ABNF grammar:

```

RST-Information ::= < AVP Header: 224>
                  [ Server-Role ]
                  [ Session-Type ]
                  [ RST-Subscriber-ID ]
    
```

7.2.2.4 *RST-Subscriber-ID*

The *RST-Subscriber-ID AVP* (AVP code 225) is of type UTF8String and contains the IMPU of the RST subscriber for which the feature was invoked.

7.2.2.5 *Server-Role*

The *Server-Role AVP* (AVP code 226) is of type Enumerated and contains the format of the application name.

It can be one of the following values:

Call Forward Variable (CFV)	0
Call Forward Don't Answer (DFDA)	1
Call Forward Busy Line (CFBL)	2
Selective Call Forwarding (SCF)	3
Outbound Call Blocking (OCB)	4
Selective Call Blocking (SCB)	5
Customer Originated Trace (COT)	6
Call Transfer (CT)	7
Automatic Recall (AR)	8
Automatic Callback (AC)	9

7.2.2.6 *Session-Type*

The *Session-Type AVP* (AVP code 227) is of type Enumerated and contains the format of the application type.

It can be one of the following values:

Activation	1
De-activation	2
Session establishment	3
Subscribe	4
Notify	5
Call Block	6
Call Block Override	7
Call Block Disabled	8
Reference	9

Success	10
Delay_Success	11
Failure_Timeout	12
Failure_SUBS_Limit	13
Failure_Dialog	14
Failure_Identity	15

7.2.2.7 Target

The *Target AVP* (AVP code 230) is of type UTF8String and contains the SIP Call-ID for the original call (the A – B call).

7.2.2.8 Transfer-Session-Call-ID

The *Transfer-Session-Call-ID AVP* (AVP code 232) is of type UTF8String and contains the SIP Call-ID for the transfer session (the A – C call).

Appendix I Acknowledgements

We wish to thank the vendor participants contributing directly to this document:

David Ensign – Cisco

Tom Miller – Siemens

Jim Stanco – Siemens

Marc Price – Openet

Mohammad Torabi– Lucent

Sorin Georgescu – Ericsson

Brent Agnew – Broadsoft

Tom Hallin - Motorola

Kevin Johns - CableLabs

Appendix II Revision History

The following Engineering Change Notices were incorporated in PKT-SP-RST-ACCT-I02-070925.

ECN	ECN Date	Summary
RST-ACCT-N-07.0456-3	6/25/07	Auto Recall/Callback Deactivation
RST-ACCT-N-07.0468-2	7/16/07	Alignment with 3GPP IMS Release 7 and other reference updates

The following Engineering Change Notice was incorporated in PKT-SP-RST-ACCT-I03-080425.

ECN	ECN Date	Summary
RST-ACCT-N-08.0507-1	3/24/08	Updates for 3GPP Dec 07 R7 alignment
