

Superseded

by a later version of this document

PacketCable™ Applications

PacketCable High Definition Voice with DECT Specification

PKT-SP-DECT-HDV-I02-090917

ISSUED

Notice

This PacketCable specification is the result of a cooperative effort undertaken at the direction of Cable Television Laboratories, Inc. for the benefit of the cable industry and its customers. This document may contain references to other documents not owned or controlled by CableLabs. Use and understanding of this document may require access to such other documents. Designing, manufacturing, distributing, using, selling, or servicing products, or providing services, based on this document may require intellectual property licenses from third parties for technology referenced in this document.

Neither CableLabs nor any member company is responsible to any party for any liability of any nature whatsoever resulting from or arising out of use or reliance upon this document, or any document referenced herein. This document is furnished on an "AS IS" basis and neither CableLabs nor its members provides any representation or warranty, express or implied, regarding the accuracy, completeness, noninfringement, or fitness for a particular purpose of this document, or any document referenced herein.

© Copyright 2009 Cable Television Laboratories, Inc.
All rights reserved.

Document Status Sheet

Document Control Number:	PKT-SP-DECT-HDV-I02-090917			
Document Title:	PacketCable High Definition Voice with DECT Specification			
Revision History:	I01 - Released 02/26/09 I02 - Released 09/17/09			
Date:	September 17, 2009			
Status:	Work in Progress	Draft	Issued	Closed
Distribution Restrictions:	Author Only	GL/Member	GL/Member/Vendor	Public

Key to Document Status Codes

- Work in Progress** An incomplete document, designed to guide discussion and generate feedback that may include several alternative requirements for consideration.
- Draft** A document in specification format considered largely complete, but lacking review by Members and vendors. Drafts are susceptible to substantial change during the review process.
- Issued** A stable document, which has undergone rigorous member and vendor review and is suitable for product design and development, cross-vendor interoperability, and for certification testing.
- Closed** A static document, reviewed, tested, validated, and closed to further engineering change requests to the specification through CableLabs.

Trademarks

CableLabs®, DOCSIS®, EuroDOCSIS™, eDOCSIS™, M-CMTS™, PacketCable™, EuroPacketCable™, PCMM™, CableHome®, CableOffice™, OpenCable™, OCAP™, CableCARD™, M-Card™, DCAS™, tru2way™, and CablePC™ are trademarks of Cable Television Laboratories, Inc.

DECT™ is a trademark of ETSI. DECT CAT-iq™ is a trademark of the DECT Forum.

Contents

1	SCOPE	1
1.1	Introduction and Purpose.....	1
1.2	Requirements.....	1
2	REFERENCES	2
2.1	Normative References.....	2
2.2	Informative References.....	2
2.3	Reference Acquisition.....	3
3	TERMS AND DEFINITIONS	4
4	ABBREVIATIONS AND ACRONYMS	5
5	OVERVIEW	6
5.1	Service Objectives for HD Voice Support in PacketCable Specifications.....	6
5.2	Strategy for Leveraging DECT CAT-iq™.....	8
6	TECHNICAL REQUIREMENTS	11
6.1	DECT Integration.....	11
6.2	Codec requirements.....	12
6.2.1	Codec Negotiation.....	12
6.3	DTMF Digit Processing.....	16
6.4	Hook Status.....	17
6.4.1	Off-hook Transitions.....	17
6.4.2	On-hook transitions.....	17
6.5	Hook Flash Detection.....	18
6.6	Tone Generation.....	18
6.6.1	Local Tone Generation.....	18
6.6.2	Network Tone Generation.....	19
6.7	Caller ID Delivery.....	19
6.8	Ring Generation.....	19
6.9	VMWI Delivery.....	20
6.10	Barge-In.....	20
6.11	Internal Call Requirements.....	22
6.12	Service Status.....	22
6.13	VoIP Metrics Package Interoperability for DECT.....	23
6.13.1	Packet Loss and Discard.....	23
6.13.2	Delay Metrics.....	23
6.13.3	Signal Metrics.....	23
6.13.4	Call Quality.....	24
6.14	Emergency Services.....	25
6.15	Operator Services.....	25
6.16	Fax, Modem and TDD Interoperability for DECT.....	25
6.17	IP Transparent Data Services.....	25
6.18	Security.....	25
6.19	Provisioning.....	25
6.20	Interoperability with Legacy Home Alarm Systems.....	25
6.20.1	Preemption for the Alarm System.....	26
6.20.2	Simultaneous Calls for the Alarm System.....	27
6.21	Network-Based Call Screening.....	28
6.22	Multi-line Support.....	29

7 DECT MESSAGES31

7.1 CC-SETUP 31

7.2 CC-SETUP-ACK..... 32

7.3 CC-INFO 32

7.4 CC-ALERTING..... 32

7.5 CC-CONNECT..... 32

7.6 CC-CONNECT-ACK..... 33

7.7 CC-SERVICE-CHANGE..... 33

7.8 CC-SERVICE-ACCEPT 33

7.9 CC-SERVICE-REJECT 33

7.10 IWU-INFO 33

7.11 CC-RELEASE..... 33

7.12 CC-RELEASE-COM..... 33

7.13 FACILITY 33

APPENDIX I ACKNOWLEDGEMENTS34

APPENDIX II REVISION HISTORY35

Figures

Figure 1 - PacketCable Clients with HD Voice via DECT.....6

Figure 2 - Relationship between client and FP.....7

Figure 3 - PacketCable HD Voice Specifications.....8

Figure 4 - Leveraging DECT for HD Voice.....9

Figure 5 - Network Based Call Screening Call Flow Example29

Tables

Table 1 - Features leveraged from ETSI [TS 102 527-1].....9

Table 2 - Features leveraged from ETSI [TS 102 527-2].....10

Table 3 - Features leveraged from ETSI [TS 102 527-3].....10

Table 4 - DECT Handsets Serviced By FP.....11

Table 5 - HD Voice Profile11

Table 6 - Preferred Codec List for the DECT Air Interface13

Table 7 - Examples of DECT Air Interface Codec Selection.....15

Table 8 - DTMF Tone Duration17

Table 9 - Barge-In Feature Data.....20

Table 10 - Service Status Feature Data23

Table 11 - Analog Line Configuration for Alarm Systems26

Superseded*by a later version of this document*

1 SCOPE

1.1 Introduction and Purpose

This specification includes High Definition (HD) Voice requirements for PacketCable 1.5 and PacketCable 2.0 networks. The PacketCable specifications leverage Digital Enhanced Cordless Telephone (DECT™) technologies to incorporate HD Voice. A minimum set of DECT capabilities for HD Voice service is identified.

1.2 Requirements

Throughout this document, the words that are used to define the significance of particular requirements are capitalized. These words are:

"MUST"	This word means that the item is an absolute requirement of this specification.
"MUST NOT"	This phrase means that the item is an absolute prohibition of this specification.
"SHOULD"	This word means that there may exist valid reasons in particular circumstances to ignore this item, but the full implications should be understood and the case carefully weighed before choosing a different course.
"SHOULD NOT"	This phrase means that there may exist valid reasons in particular circumstances when the listed behavior is acceptable or even useful, but the full implications should be understood and the case carefully weighed before implementing any behavior described with this label.
"MAY"	This word means that this item is truly optional. One vendor may choose to include the item because a particular marketplace requires it or because it enhances the product, for example; another vendor may omit the same item.

2 REFERENCES

2.1 Normative References

In order to claim compliance with this specification, it is necessary to conform to the following technical specifications, standards and other works as indicated, in addition to the other requirements of this specification. Notwithstanding, intellectual property rights may be required to use or implement such normative references.

[CODEC MEDIA]	PacketCable Codec and Media Specification, PKT-SP-CODEC-MEDIA-I07-090702, July 2, 2009, Cable Television Laboratories, Inc.
[CODEC 1.5]	PacketCable Audio/Video Codecs, PKT-SP-CODEC1.5-I03-90624, June 24, 2009, Cable Television Laboratories, Inc.
[DECT-PROV]	PacketCable DECT Provisioning Specification, PKT-SP-DECT-PROV-I02-090917, September 17, 2009, Cable Television Laboratories, Inc.
[EN 300 444]	ETSI EN 300 444, Digital Enhanced Cordless Telecommunications (DECT); Generic Access Profile (GAP), V2.1.0, June 2008.
[RFC 3551]	IETF RFC 3551/STD0065, RTP Profile for Audio and Video Conferences with Minimal Control, July 2003.
[TS 102 527-1]	ETSI TS 102 527-1, Digital Enhanced Cordless Telecommunications (DECT); New Generation DECT; Part 1: Wideband speech, V1.2. June 2008.
[TS 102 527-2]	ETSI TS 102 527-2 V1.1.1, Digital Enhanced Cordless Telecommunications (DECT); New Generation DECT; Part 2: Support of transparent IP packet data, V1.1.1, June 2007.
[TS 102 527-3]	ETSI TS 102 527-3, Digital Enhanced Cordless Telecommunications (DECT); New Generation DECT; Part 3: Extended wideband speech services, V1.1.1, June 2008.

2.2 Informative References

This specification uses the following informative references.

[AIP1.5]	PacketCable Embedded MTA Analog Interface and Powering Specification, PKT-SP-AIP1.5-I02-070412, April 12, 2007, Cable Television Laboratories, Inc.
[ARCH-FRM TR]	PacketCable Architecture Framework Technical Report, PKT-TR-ARCH-FRM-V06-090528, May 28, 2009, Cable Television Laboratories, Inc.
[DECT-NCS]	PacketCable DECT NCS Specification, PKT-SP-DECT-NCS-I02-090917, September 17, 2009, Cable Television Laboratories, Inc.
[DECT-SIP]	PacketCable DECT SIP Specification, PKT-SP-DECT-SIP-I02-090917, September 17, 2009, Cable Television Laboratories, Inc.
[E-DVA]	PacketCable Residential SIP Telephony E-DVA Specification, PKT-SP-RST-E-DVA-I05-090528, May 28, 2009, Cable Television Laboratories, Inc.
[EN 300 175-1]	ETSI EN 300 175-1, Digital Enhanced Cordless Telecommunications (DECT); Common Interface (CI); Part 1: Overview, V2.2.0, June 2008.
[EN 300 175-2]	ETSI EN 300 175-2, Digital Enhanced Cordless Telecommunications (DECT); Common Interface (CI); Part 2: Physical Layer (PHL), V2.2.0, June 2008.
[EN 300 175-3]	ETSI EN 300 175-3, Digital Enhanced Cordless Telecommunications (DECT); Common Interface (CI); Part 3: Medium Access Control (MAC) layer, V2.2.0, June 2008.
[EN 300 175-4]	ETSI EN 300 175-4, Digital Enhanced Cordless Telecommunications (DECT); Common Interface (CI); Part 4: Data Link Control (DLC) layer, V2.2.0, June 2008.

- [EN 300 175-5] ETSI EN 300 175-5, Digital Enhanced Cordless Telecommunications (DECT); Common Interface (CI); Part 5: Network (NWK) layer, V2.2.0, June 2008.
- [EN 300 175-6] ETSI EN 300 175-6, Digital Enhanced Cordless Telecommunications (DECT); Common Interface (CI); Part 6: Identities and addressing, V2.2.0, June 2008.
- [EN 300 175-7] ETSI EN 300 175-7, Digital Enhanced Cordless Telecommunications (DECT); Common Interface (CI); Part 7: Security features, V2.2.0, June 2008.
- [EN 300 175-8] ETSI EN 300 175-8, Digital Enhanced Cordless Telecommunications (DECT); Common Interface (CI); Part 8: Speech and audio coding and transmission, V2.1.2, June 2008.
- [RFC 3611] IETF RFC 3611, RTP Control Protocol Extended Reports (RTCP XR), November 2003.
- [RSTF] PacketCable Residential SIP Telephony Specification, PKT-SP-RSTF-I05-090528, May 28, 2009, Cable Television Laboratories, Inc.

2.3 Reference Acquisition

- Cable Television Laboratories, Inc., 858 Coal Creek Circle, Louisville, CO 80027; Phone +1-303-661-9100; Fax +1-303-661-9199; <http://www.cablelabs.com>
- European Telecommunications Standards Institute (ETSI), 650, route des Lucioles, 06921 Sophia-Antipolis Cedex, France, <http://www.etsi.org/WebSite/homepage.aspx>, Tel.: +33 (0) 4 92 94 42 00, Fax: +33 (0) 4 93 65 47 16. Specifications can be found at <http://pda.etsi.org/pda/queryform.asp>.
- Internet Engineering Task Force (IETF) Secretariat, 46000 Center Oak Plaza, Sterling, VA 20166, Phone +1-571-434-3500, Fax +1-571-434-3535, <http://www.ietf.org>

3 TERMS AND DEFINITIONS

This specification uses the following terms:

Client	The terms client and PacketCable client are used interchangeably in this specification.
DECT Air Codec	The DECT Air Codec is the audio codec selected to be used on the air interface between the Fixed Part (FP) and the Portable Part (PP).
DTMF Event	A DTMF Event is the detection of a DTMF digit.
Endpoint	The term endpoint used in this specification refers to a control signaling endpoint such as an NCS endpoint or a SIP client.
Fixed Part	The Fixed Part is a portion of the cordless telephone base station defined in ETSI DECT specifications.
G.711	The term G.711 defines its use in the PSTN with two encoding laws, μ -law, used in N. America, and A-law, used elsewhere.
Off-hook Status for the client	Off-hook status at the client is when either the FP is in off-hook status, or the analog line is in off-hook status.
Off-hook Status for the FP	Off-hook status at the FP is when at least one PP is involved in a network call. Note that DECT internal calls do not affect the off-hook status of the FP.
On-hook Status for the client	On hook status at the client is when the FP status is on-hook and the analog line is on-hook or in analog intrusion denial state.
On-hook Status for the FP	On-hook status at the FP is when no PP is involved in a network call. Note that DECT internal calls do not effect the on-hook status of the FP.
PacketCable client	The PacketCable client is a PacketCable network signaling termination within the customer's CPE. Examples include the NCS client within the PacketCable 1.5 E-MTA and the PacketCable 2.0 User Equipment.
Portable Part	The Portable Part is a portion of the cordless telephone handset defined in ETSI DECT specifications.
U-plane	User-plane, or U-plane, is a DECT term referring to the transport of user traffic.

4 ABBREVIATIONS AND ACRONYMS

This specification uses the following abbreviations:

DECT	Digital Enhanced Cordless Telephone
E-DVA	Embedded Digital Voice Adaptor
E-MTA	Embedded Media Terminal Adaptor
FP	Fixed Part
GAP	Generic Access Profile
HD	High Definition
HFC	Hybrid Fiber Coax
NBCS	Network-Based Call Screening
PP	Portable Part
RTP	Real-time Transport Protocol
S-DVA	Stand-alone Digital Voice Adaptor
VMS	Voice Mail Server

5 OVERVIEW

5.1 Service Objectives for HD Voice Support in PacketCable Specifications

The PacketCable project defines interface specifications that can be used to develop interoperable equipment capable of providing packet-based voice, video and other multimedia services over Hybrid Fiber Coax (HFC) cable systems utilizing the Data-Over-Cable Interface Specifications. This specification adds High Definition voice service to PacketCable through the use of a Digital Enhanced Cordless Telephone (DECT) base station integrated with a PacketCable client. The primary service objectives of this specification include:

- High Definition Voice amongst PacketCable Clients
- Interoperability amongst DECT handsets and PacketCable clients that support the DECT base station function
- Call feature parity with existing PacketCable networks.

High definition voice is intended to substantially improve the audio quality of voice services between two PacketCable clients within the same operator network or peered networks. As illustrated in Figure 1, the PacketCable client with DECT base station may be integrated within the cable modem, or a separate unit connected to the cable modem. The PacketCable client controls the traditional analog line per existing PacketCable specifications and interfaces to the DECT base station function referred to as the Fixed Part (FP). The FP is defined in ETSI DECT specifications. The PacketCable client to FP interface protocol is not defined in this specification, and this specification does not intend to force a specific implementation of this interface. The specification does, however, require interactions between the PacketCable client and the FP for the sake of interoperability between PacketCable and DECT. The PacketCable specifications strive to ensure interoperability between the DECT cordless phone and the DECT base station function. The scope of this specification is focused on interoperability requirements with HD handsets or Portable Parts (PPs); however, this does not prohibit the FP and client from supporting narrowband PPs compliant with the ETSI Generic Access Profile (GAP).

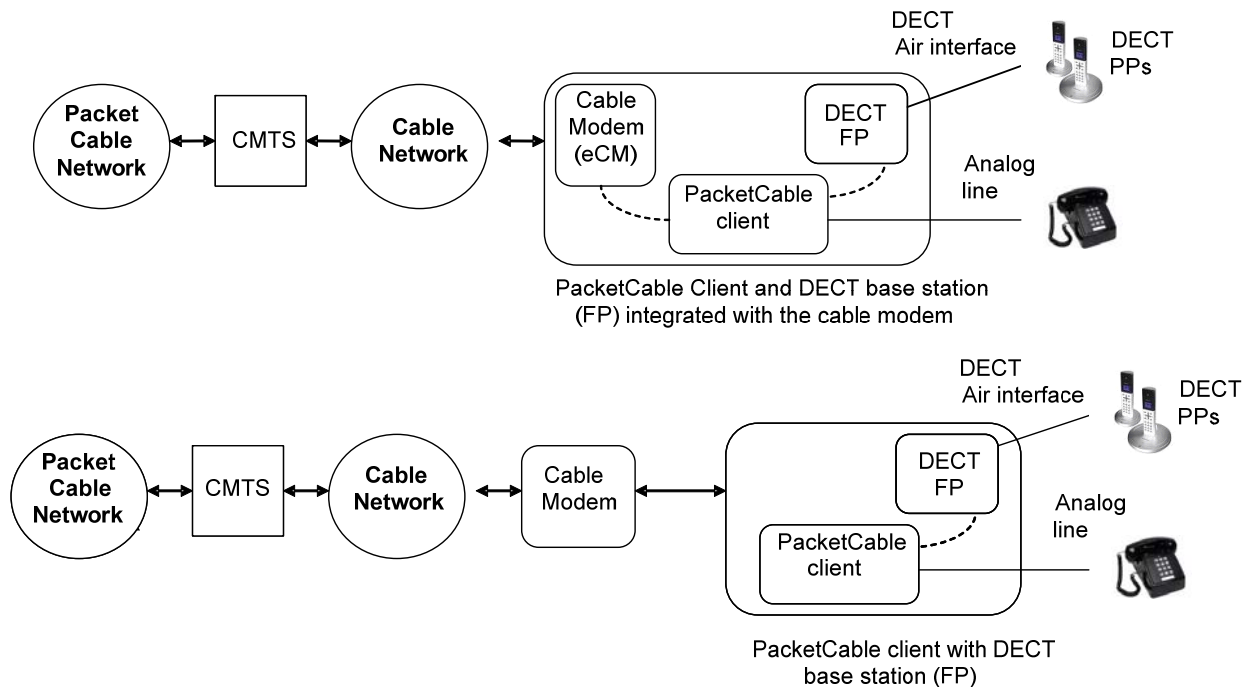

Figure 1 - PacketCable Clients with HD Voice via DECT

Figure 2 below provides a closer view of the relationship between the FP and PacketCable client. The FP manages the DECT signaling with the PPs, and therefore provides the client a composite status view of the state of the PPs. For example, the FP can provide an on-hook status to the client when all PPs are either on hook or involved in internal calls. See Section 6 for details on the status available to the client from the FP. The client may also manage an analog line and detect the analog phone status based on PacketCable specifications. The client uses the status of the FP and analog line when signaling to the PacketCable network. The interface to the network is either SIP or NCS as specified in PacketCable specifications. Note that the terms PacketCable client, and client, are used interchangeably in this specification.

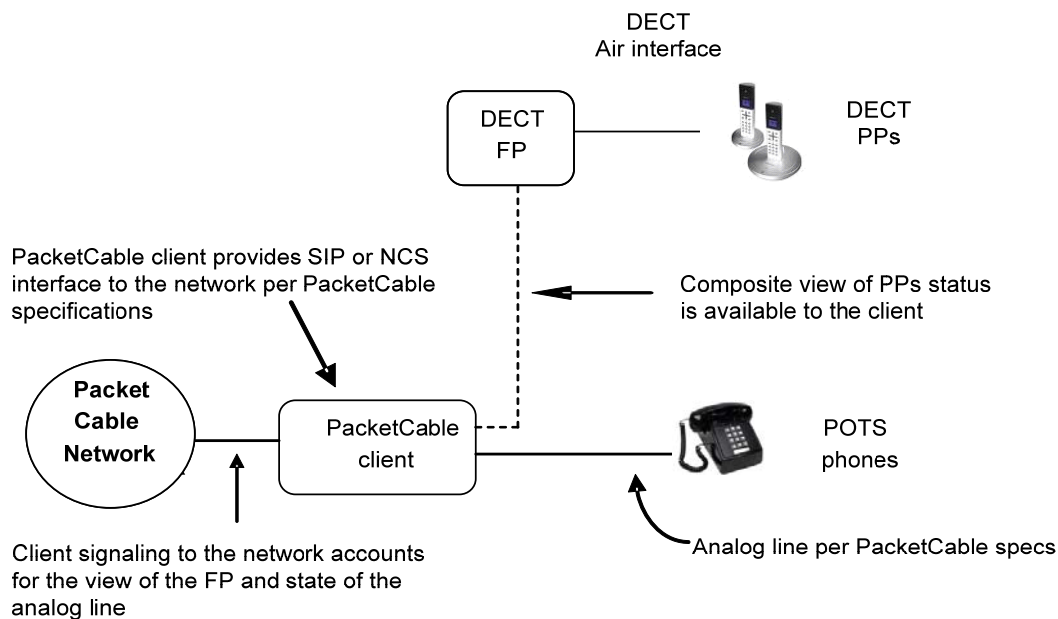

Figure 2 - Relationship between client and FP

HD Voice is a PacketCable Application that can be applied to both PacketCable 1.5 and PacketCable 2.0 networks. Refer to [ARCH-FRM TR] for a description of the PacketCable architecture. The figure below illustrates the relationship amongst the PacketCable HD Voice specifications (this specification, [DECT-NCS] and [DECT-SIP]), and other PacketCable specifications. This document, the PacketCable DECT Specification, applies HD Voice requirements that are common to both PacketCable 1.5 and PacketCable 2.0 networks. More specifically, requirements placed on the PacketCable client in this specification apply to PacketCable 1.5 NCS clients for PacketCable 1.5 networks. Requirements placed on the PacketCable client in this specification also apply to the PacketCable 2.0 UE for PacketCable 2.0 networks.

The [DECT-NCS] Specification places requirements on PacketCable 1.5 clients that interface to the FP for DECT and NCS interoperability. The [DECT-NCS] Specification also mandates the set of PacketCable 1.5 specifications applicable to PacketCable 1.5 clients that can reside in E-MTAs.

The [DECT-SIP] Specification places requirements on the PacketCable 2.0 client that interface to the FP for DECT and SIP interoperability. The [DECT-SIP] Specification refers to the PacketCable Residential SIP Telephony [RSTF] and PacketCable Embedded DVA [E-DVA] Specifications for residential telephony services. The [DECT-SIP] Specification also mandates the set of PacketCable 2.0 specifications applicable to PacketCable 2.0 clients that can reside in E-DVAs or S-DVAs.

PacketCable provisioning requirements are updated to accommodate HD Voice with DECT. See the [DECT-PROV] Specification for provisioning requirements related to HD Voice.

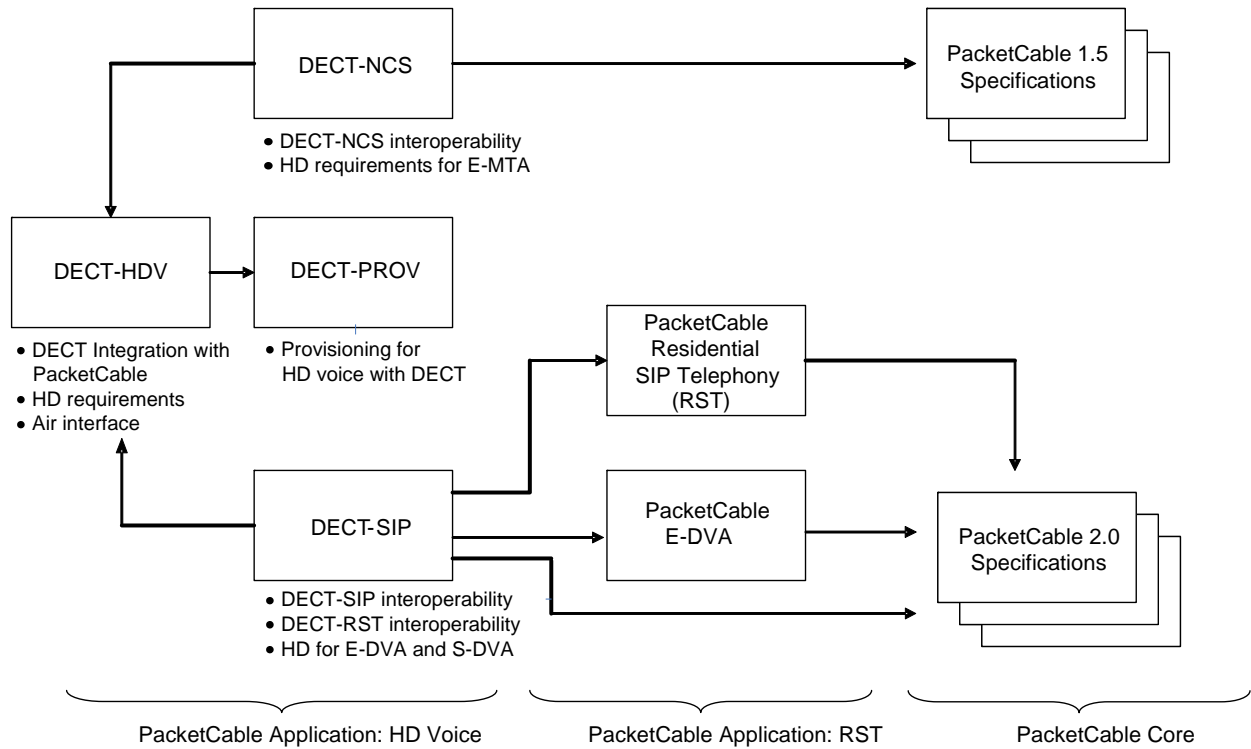

Figure 3 - PacketCable HD Voice Specifications

5.2 Strategy for Leveraging DECT CAT-iq™

PacketCable has identified the DECT Forum's CAT-iq technology for the air interface to support HD Voice. CAT-iq provides both wideband voice codecs for HD voice services as well as internet capabilities that can support advanced data service. As illustrated in Figure 4, Wideband voice services for CAT-iq are defined in ETSI [TS 102 527-1]. DECT also defines a Generic Access Profile in ETSI [EN 300 444] that is intended to ensure a minimum level of interoperability between the handset and base station. The GAP mandates specific functions at all layers of the air interface that are defined in the Common Interface set of specifications, [EN 300 175-1] through [EN 300 175-8]. PacketCable specifications mandate the GAP and Wideband voice services specifications. Advanced Wideband Services are defined in ETSI [TS 102 527-3], and provide an expanded set of supplementary telephony services. PacketCable mandates certain capabilities from [TS 102 527-3] in order to provide future migration to more advanced services. PacketCable mandates support of Transparent IP Packet Data services at the FP as defined in [TS 102 527-2].

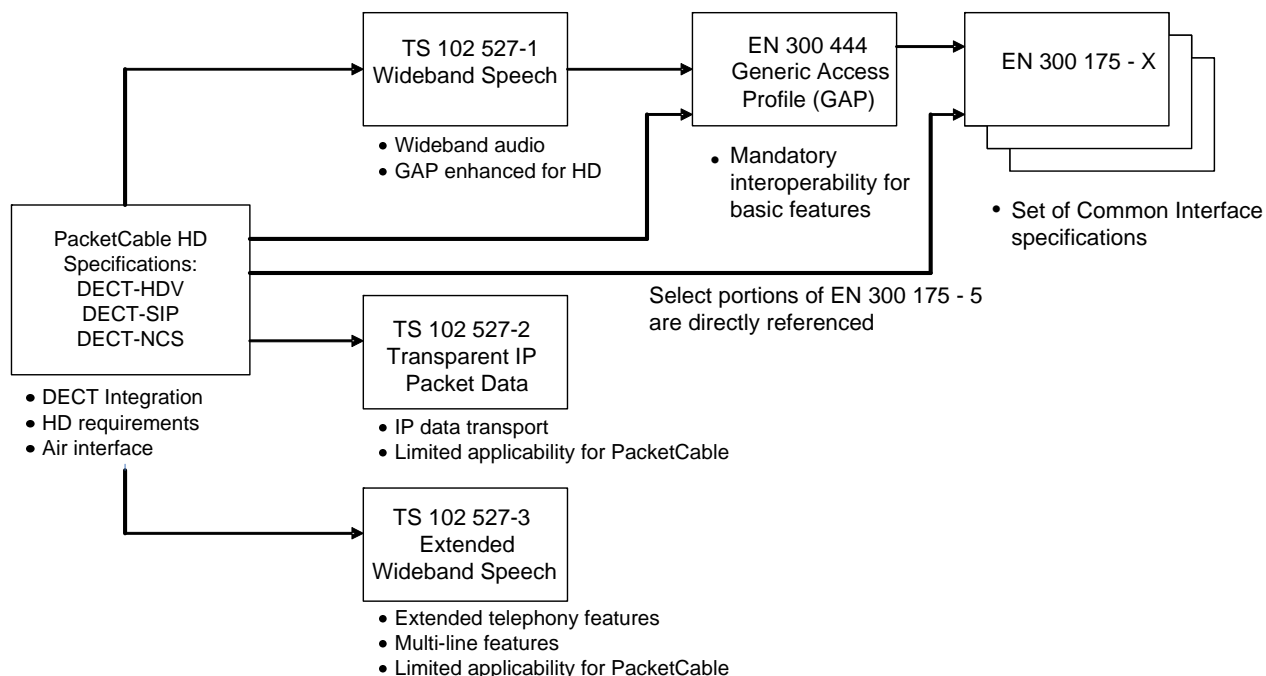

Figure 4 - Leveraging DECT for HD Voice

The following tables show the relationship between the ETSI and PacketCable specifications in more detail. It is to be noted that these tables are informative in nature, and the normative text in this document takes precedence over the text in these tables in case of discrepancies between the two.

Table 1 shows the features leveraged from ETSI [TS 102 527-1], maps them to the corresponding PacketCable HD voice features and highlights differences in the strength of specific feature requirements between ETSI and PacketCable. The assumption is that there are no additional differences beyond those highlighted in the tables. ETSI [TS 102 527-1] is also known as the Basic profile ("vb") or as CAT-iq 1.0.

Table 1 - Features leveraged from ETSI [TS 102 527-1]

Features leveraged from ETSI spec	Corresponding PacketCable HD Voice feature	Difference in strength of requirements between ETSI and PacketCable
Wideband speech (both FP and PP) Mandatory codecs (both FP and PP) Codec negotiation and codec change procedures (both FP and PP)	Codec requirements (Section 6.2)	G.711 codec is optional on both FP and PP in ETSI, mandated on both FP and PP in PacketCable. PacketCable codecs can be optionally used on the DECT air interface.

Table 2 shows the features leveraged from ETSI [TS 102 527-2] and highlights any differences in the strength of specific feature requirements between ETSI and PacketCable.

Table 2 - Features leveraged from ETSI [TS 102 527-2]

Features leveraged from ETSI spec	Corresponding PacketCable HD Voice feature	Difference in strength of requirements between ETSI and PacketCable
Transparent IP Packet Data services (only FP)	To support migration to data services without a need for upgrade on the FP	PacketCable FP is required to support transparent IP packet data services as defined in the ETSI spec.

Table 3 shows the features leveraged from ETSI [TS 102 527-3], maps them to the corresponding PacketCable HD voice features and highlights differences (if any) in the strength of specific feature requirements between ETSI and PacketCable. The assumption is that there are no additional differences beyond those highlighted in the table. ETSI [TS 102 527-3] is also known as the Extended profile ("ve") or as CAT-iq 2.0.

Table 3 - Features leveraged from ETSI [TS 102 527-3]

Features leveraged from ETSI spec	Corresponding PacketCable HD Voice feature	Difference (if any) in strength of requirements between ETSI and PacketCable
Implicit call intrusion procedures (FP only)	Barge-In (Section 6.10)	Optional on FP in ETSI, Mandatory on FP in PacketCable
Explicit call intrusion procedures (both FP and PP)	Barge-In (Section 6.10)	Optional on both FP and PP in ETSI, Mandatory on both FP and PP in PacketCable
Internal calls (including wideband) (both FP and PP)	Internal Call (Section 6.11)	No difference (mandated on both FP and PP in both ETSI and PacketCable)
List access (both FP and PP) Specific lists: List of Supported Lists, Internal Names, Line Settings, and DECT System Settings	Multi-line support (Section 6.22)	No difference (List access and these specific lists are mandated on both FP and PP in both ETSI and PacketCable)
Line identification (both FP and PP)	Multi-line support (Section 6.22)	No difference (Line identification is optional on PP and mandatory on FP in both ETSI and PacketCable)

6 TECHNICAL REQUIREMENTS

6.1 DECT Integration

This section describes the integration of the DECT FP and PacketCable client. The PacketCable client MUST interface to the FP and support at least one analog port. The FP supports one or more PPs. The PacketCable single line client MUST support the same directory number or other public user identities assigned across to each PP and the analog line so that an incoming call may ring all devices. The FP MUST report to the network the number of PPs it is able to support as shown in Table 4 and as specified in the [DECT-PROV] spec. The FP MUST limit the number of simultaneously registered PPs as configured by the network operator as shown in Table 4.

Table 4 - DECT Handsets Serviced By FP

Data	Type	Persistence	Default Value	Range	Scope	Provisioning Requirement
Maximum number of PPs supported by the capability of the FP	Integer	Persistent	N/A	N/A	Per FP	Mandatory Read-Only
Maximum number of PPs supported as provisioned	Integer	Volatile	N/A.	0...10	Per FP	Mandatory Read-Write

The PP and FP are required to support DECT air interface requirements as defined by the Generic Access Profile (GAP) specification in [EN 300 444], and the Wideband Speech specification in [TS 102 527-2]. Selected capabilities from the Extended Wideband speech services specification [TS 102 527-3] are called out in individual requirements.

The FP MUST support the DECT air interface requirements specified in [EN 300 444] and [TS 102 527-1] for FPs.

The PP MUST support the DECT air interface requirements specified in [EN 300 444] and [TS 102 527-1] for PPs.

The FP MUST report to the network the HD profile capabilities it provides as indicated in Table 5.

Table 5 - HD Voice Profile

Data	Type	Persistence	Default Value	Range	Scope	Provisioning Requirement
HD Voice Profile	Enumerated List	N/A	N/A	0 – HD is not supported 1 – Basic HD-Voice Profile as defined in this specification	Per FP	Mandatory Read-Only

The HD Voice Profile indicates the feature sets supported by the FP, as shown in the list below:

- A value of 0 indicates that HD voice and FP functions per this specification are not supported.
- A value of 1 indicates basic High Definition residential voice as specified in this specification and [DECT-NCS] or [DECT-SIP].

6.2 Codec requirements

6.2.1 Codec Negotiation

6.2.1.1 References

[EN 300 175-5] defines the <<CODEC-LIST>> information element that may be used in DECT Call Control messages. The Codec Negotiation procedures, however, are defined in [TS 102 527-1] and are summarized below.

A well-defined procedure is used during PP registration to communicate the list of supported codecs to the FP. This is accomplished via the <<CODEC-LIST>> information element. This information is included in ACCESS-RIGHTS-REQUEST, ACCESS-RIGHTS-ACCEPT, LOCATE-REQUEST and LOCATE-ACCEPT messages. The PP SHOULD indicate Codec Negotiation is possible. The FP SHOULD also indicate that Codec Negotiation is possible.

The basic service wideband speech with default attributes procedure is defined below. This provides a mechanism to indicate to the other side that default values associated with the service are to be used. The PP MUST provide a list of codecs it supports in the <<CODEC-LIST>> Information Element for Codec Negotiation purposes.

Codec Negotiation during call establishment is defined in [TS 102 527-1]. Many aspects of this codec negotiation exchange are described in subsequent sections below.

The FP MAY change the codec after call setup as specified by the Codec Change procedure defined in [TS 102 527-1].

The PP and FP MUST support the Codec Negotiation and Codec Change procedures defined in [TS 102 527-1].

6.2.1.2 PacketCable DECT Air Interface and Codec Configuration

The PacketCable DECT Provisioning Specification [DECT-PROV] defines configuration parameters related to the support and negotiation of codecs over the DECT Air interface.

The first configuration parameter indicates the list of codecs the FP supports. The FP MUST indicate the list of codecs it supports over the DECT air interface as indicated in Table 6 per the [DECT-PROV] Specification.

The second configuration parameter contains the prioritized list of codecs to be used by the FP over the DECT air interface during codec negotiation; it may be a sub-set of the FP's supported codecs. This list is used to better control the codecs proposed during codec negotiation between the FP and PP. It helps determine the initial compatible codec(s) used over the DECT air interface before the network-side codec negotiation occurs. The configured codec list is also used to choose the DECT air codec for codec renegotiation after the initial network codec negotiation completes. The list is prioritized in that the first codec in the list is the preferred codec; the second in the list is the next preferred, etc.

The FP MUST allow the configuration of a preferred list of codecs for the DECT air interface as a read-write object with a default value that can be overwritten by the cable operator's provisioning systems as indicated in Table 6.

Table 6 - Preferred Codec List for the DECT Air Interface

Data	Type	Persistence	Default Value	Range	Scope	Provisioning Requirement
Codecs supported by the FP	List, Textual	N/A	N/A	All supported codecs	Per FP	Mandatory Read-Only
Preferred codec list for DECT Air interface	List, Textual	Volatile	"G.722, PCMU, PCMA"	All supported codecs	Per FP	Mandatory Read-Write

The FP MUST support Audio codecs in the lists specified by using encoding names defined in the RTP AV Profile [RFC 3551], encoding names registered with the IANA, or encoding names referenced in the PacketCable Audio/Video Codecs Specification, [CODEC 1.5], or the PacketCable Codec-Media Specification, [CODEC MEDIA]. The range of codecs in the table above includes the codecs identified in [TS 102 527-1], [CODEC 1.5], and [CODEC MEDIA]. The range does not indicate which codecs are mandatory to support.

6.2.1.3 FP and PP Codec Requirements

The FP MUST support G.722, G.711 and mandatory codecs specified in [TS 102 527-1]. The FP MAY support other codecs specified in [TS 102 527-1], [CODEC 1.5], and [CODEC MEDIA].

The PP MUST support G.722, G.711 and mandatory codecs specified in [TS 102 527-1]. The PP MAY support other codecs specified in [TS 102 527-1], [CODEC 1.5], and [CODEC MEDIA].

6.2.1.4 Codec Negotiation over DECT Air Interface

For outbound calls (i.e., calls initiated by the PP toward the network), the PP may include a list of codecs in the <<CODEC-LIST>> information element; otherwise, the <<CODEC-LIST>> provided during the last successful registration is used. The FP MUST choose the highest priority codec from the intersection of the <<CODEC-LIST>> provided by the PP and the preferred codec list (as provided during configuration). The FP MUST set the <<CODEC-LIST>> information element to the highest priority codec in a subsequent response message when codec negotiation over the network is not yet complete.

For inbound calls or signal requests resulting in a CC-SETUP message being issued by the FP to a PP where Codec Negotiation over the network has not been initiated or is not yet complete, the FP MUST set the <<CODEC-LIST>> information element according to the preferred codec list. The first supported codec from this configured list is either the first codec included in the <<CODEC-LIST>> information element or the only codec indicated by the FP.

When codec negotiation on the network is not complete and the FP includes multiple codecs in the <<CODEC-LIST>> of a CC-SETUP message, then the FP MUST set the list to either the full list or a sub-set of the configured preferred list of codecs and in the same prioritized order. For example, if the configured preferred codec list is "G.722, PCMU, PCMA, G.726" and the FP wishes to offer G.722, PCMU, and G.726 only, then the <<CODEC-LIST>> is set to "G.722, PCMU, G.726". A <<CODEC-LIST>> set to "G.722, G.726, PCMU", for example, is not used since it breaks the priority requirement.

In general, the FP SHOULD start with a codec over the DECT air interface that requires the largest slot type that may be used during the call to avoid switching from a lower bandwidth slot type to a higher bandwidth slot type later. Likewise, the PP SHOULD start with a codec over the DECT air interface that requires the largest slot type that may be used during the call to avoid switching from a lower bandwidth slot type to a higher bandwidth slot type later. If the negotiation on the network later results in the use of a codec that requires less bandwidth over the DECT air, then it is easier to switch from the higher bandwidth slot to the lower bandwidth slot since fewer resources are needed. An attempt to switch from a lower bandwidth slot to a higher bandwidth slot not only takes longer to execute, but may fail due to lack of available resources.

6.2.1.5 Codec Negotiation over the Network

To some extent, codec negotiation over the network is independent of Codec Negotiation over the DECT air interface. The codec or codecs negotiated simply drive the required resources over the DECT air interface – slot type and codec. Once codec negotiation over the network is complete, the highest bit rate codec in the negotiated list is used to determine the resources used over the DECT air interface. Note that the highest bit rate codec might not be the active codec used from the negotiated list of codecs for a single connection, but may become active during the duration of the call.

For example, if the negotiated list of codecs over the network is "G729E, PCMU" then the active codec over the network is G729E, but the highest bit rate codec is PCMU. Therefore, the resources chosen over the DECT air interface are based on PCMU, not G729E.

See [DECT-SIP] and [DECT-NCS] for network codec requirements applicable to the PacketCable client.

6.2.1.6 DECT Air Resource Selection

The codec selected over the DECT air interface by the FP MUST be included in the preferred list of codecs unless the FP is unable to obtain the resources required, but other lower bit rate resources are available. To avoid voice degradation, the FP SHOULD choose the corresponding slot type such that the same or higher bit rate as the highest bit rate codec from the negotiated list of codecs over the network may be supported. The FP MUST initially choose the slot type based on available codecs from the preferred codec list.

The preferred codec list may be used to restrict the use of a particular slot type. This is accomplished by excluding all codecs that require that slot type. When configured as such, the FP MUST NOT initially attempt to use that particular slot type. The FP MAY use a lower bit rate slot type if a required higher bit rate slot type is unavailable at the time. If the FP uses a restricted lower bandwidth slot type, then the FP SHOULD choose the mandatory codec as specified by DECT [TS 102 527-1]. For example, the mandatory codec used for full slot is G.726.

If the highest bit rate codec determined during network codec negotiation maps to a particular slot type based on bit rate, but the slot type is not allowed and a higher bandwidth slot type is allowed, then the FP SHOULD use the next higher slot type available. If no such higher bandwidth slot type is allowed, then the FP SHOULD use the next allowed lower bandwidth slot type.

For example, if the only codecs supported by the FP that require long slot are PCMU, PCMA and G.722, but none of these codecs are in the preferred codec list, then the FP will not attempt to use long slot over the DECT air interface. Likewise, if all of the codecs in the configured list require long slot, then long slot will at least be attempted over the DECT air interface.

Once the DECT slot type is determined, the FP MUST choose the codec from the intersection of the following codec lists:

- Preferred codec list for the DECT air interface.
- List of codecs supported over the DECT air interface utilizing the chosen slot type.

If the intersection results in more than one codec, then the FP SHOULD use a codec from the list that matches the highest fidelity (narrowband or wideband) used on the network and, when possible, matches an actual codec used on the network. When multiple codecs meet the above criteria, the FP SHOULD select the highest priority codec based on the order of codecs provided in the preferred codec list.

When multiple connections exist on the endpoint, the codec selection over the DECT air codec becomes a little more complex. The basic concept remains the same. The only difference is that the set of network codecs used to determine the DECT air resources comes from the union of the negotiated list of codecs for all connections.

Table 7 contains examples that illustrate the concepts described above.

Table 7 - Examples of DECT Air Interface Codec Selection

Negotiated Prioritized List of Network Codecs	Preferred Codec List (provided by configuration and prioritized)	Slot Type Preferred (based on network Codecs)	Slot Type Chosen (based on configured Codecs)	DECT Air Codecs Available on Slot Type (i.e., intersected list of Codecs)	Prioritized List of Codecs That Match Highest Fidelity on Network	Prioritized list of Codecs That Match Highest Fidelity and Actual Network Codec	Codec Chosen over DECT Air Interface	
							Long Slot Available	Long Slot Unavailable
G.722, PCMU	G.722, PCMU, G.726	Long	Long	G.722, PCMU	G.722	G.722	G.722	G.726
PCMU, G.729E	G.722, PCMU, G.726	Long	Long	G.722, PCMU	PCMU	PCMU	PCMU	G.726
G.729E, PCMU	G.722, PCMU, G.726	Long	Long	G.722, PCMU	PCMU	PCMU	PCMU	G.726
G.729E	G.722, PCMU, G.726	Full	Full	G.726	Null	Null	N/A	G.726
G.729E	G.722, PCMU	Full	Long	G.722, PCMU	PCMU	Null	PCMU	G.726
PCMU, G.729E	G.722, G.726	Long	Long	G.722	G.722	Null	G.722	G.726
G.722	PCMA, PCMU, G.726	Long	Long	PCMA, PCMU	Null	Null	PCMA	G.726

6.2.1.7 Clarifications on DECT Specifications: Codec Negotiation

PPs MUST be Codec Negotiation capable. [TS 102 527-1] states that "the transmitting side shall always indicate "Codec Negotiation possible" (value "001") in the IE <<CODEC LIST>>."

In the CC-SETUP messages used to establish network-based calls, the FP MUST include the <<BASIC-SERVICE>> information element indicating "Wideband speech default setup attributes" (basic service = 88). Likewise, in the CC-SETUP messages used to establish network-based calls, the PP MUST include the <<BASIC-SERVICE>> information element indicating "Wideband speech default setup attributes" (basic service = 88). The <<CODEC-LIST>> provides a list of codecs in order of priority, e.g., G.722, PCMU, G.726. If not provided in a CC-SETUP message from the PP, the FP SHOULD use the default supported list provided during the last registration or location exchange.

In response to the CC-SETUP message, the <<CODEC-LIST>> information element is included with another DECT message during call setup indicating a single codec from the offered list. This is the codec that will be used over the DECT air interface. The FP MUST negotiate the codec before the U-plane is activated.

6.2.1.8 Clarifications on DECT Specifications: Support for Codec Change Procedures

The FP MUST support the codec change procedures specified in [TS 102 527-1].

The PP MUST support the codec change procedures specified in [TS 102 527-1].

6.2.1.9 Handling of Multiple Connections

As stated above, when multiple connections exist, the DECT air interface resource requirements may differ among them. For example, two connections may exist for call waiting with one connection using a codec that requires full slot and the other using a codec requiring long slot. In this type of scenario where only one connection is active at any given time, the FP MAY switch from one slot type (and subsequent codec) to the other each time the user flashes and the active connection changes.

If the first connection created on the endpoint results in the use of a lower bandwidth slot over the DECT interface, the FP SHOULD attempt to switch to a higher bandwidth slot if the list of negotiated codecs over the network changes such that a higher bandwidth slot is preferred and the configured codec list allows the use of a the higher bandwidth slot.

Once a higher bandwidth slot is set up on the DECT air interface, however, the FP SHOULD maintain it when the active connection changes as long as the use of a higher bit rate codec over the network is still possible. For example, in call waiting there may exist two connections – one requiring a lower bandwidth slot and the other requiring a higher bandwidth slot, with the higher bandwidth slot set up over the DECT air interface. Regardless of the active connection, the higher bandwidth slot SHOULD be maintained by the FP over the DECT air interface.

If, on the other hand, both connections require the same slot type, but only the codecs differ, then the FP MAY switch between corresponding codecs over the DECT air interface depending on which connection is active.

6.2.1.10 Analog Interface Interaction

When a call is initiated using an analog phone, the PacketCable client MUST negotiate codecs over the network no differently than when the call is initiated using a DECT PP. Additional capabilities are possible based on the already negotiated list of network codecs when a PP attempts to barge into an existing call. For example, assume that G.722 has been negotiated over the network for a call originated from an analog phone. Also assume that G.722 is provisioned to be the preferred codec on the air interface. A PP that barges into the call can take advantage of G.722 that has previously been negotiated over the network.

6.3 DTMF Digit Processing

DTMF digits are conveyed from the PP to the FP using the <<KEYPAD>> or <<MULTI-KEYPAD>> information element within a number of DECT call control messages. For example, the CC-INFO message with <<KEYPAD>> or <<MULTI-KEYPAD>> information elements can be used to convey DTMF digits as part of overlap sending. DECT mandates overlap sending for dialing via CC-INFO at the PP, whereas en-bloc is optional. Therefore, PacketCable interoperability with DECT en-bloc dialing is out of scope in PacketCable specifications.

DECT defines two methods to identify the length of a DTMF tone. Defined length DTMF tones are sent from the PP with a DECT control code 14H. The length of the DTMF tone is set by the FP. Infinite (or undefined) length DTMF tones are sent from the PP with a control code 16H. The tone persists until the next digit is received or a 'null' value defined by DECT is received.

DTMF events refer to the detection of a DTMF digit. The PacketCable client MUST detect DTMF events on the analog line and from the FP. The FP MUST detect DTMF events upon receipt of a valid DECT call control message from a PP for a call not destined to a device serviced by the FP and containing the <<KEYPAD>> or <<MULTI-KEYPAD>> information element with a control code of 14H with digit contents. The FP MAY detect DTMF events upon receipt of a valid DECT call control message from a PP for a call not destined to a location serviced by the FP and containing the <<KEYPAD>> or <<MULTI-KEYPAD>> information element with a control code of 16H with digit contents. The FP MUST generate separate events for each digit contained in the message and in the order in which they are received. Refer to the Sending Keypad Information procedures defined in [EN 300 444].

The FP MUST set the DTMF tone length to a value provisioned as shown in Table 8 when received from the PP with a control code value of 14H. If the FP supports infinite length DTMF tone procedures, the FP MUST set the DTMF tone length per procedures specified in [EN 300 175-5] when received from the PP with a control code value of 16H.

Table 8 - DTMF Tone Duration

Data	Type	Persistence	Default Value	Range	Scope	Provisioning Requirement
Tone Duration for DECT defined length DTMF	Decimal	Volatile	100msec	50msec-500msec	Per FP	Mandatory Read-Write

DTMF tone events are generated normally due to dialing from an off-hook phone connected to the analog interface, but only if the endpoint is not in the analog intrusion denial state. The PacketCable client MUST detect DTMF tones on the analog interface per PacketCable specifications.

The PacketCable client MUST process DTMF tone events as per the digit processing procedures called out in PacketCable specifications. This includes the treatment of critical and partial dialing. The PacketCable client MUST transmit the DTMF tones to the network as specified in PacketCable procedures.

6.4 Hook Status

This section explains how to derive a view of hook status that drives PacketCable control signaling. The hook status indicates whether the PacketCable client on a single line that serves a collection of PPs and the analog interface is in on-hook or off-hook status. The hook status of the FP is dependent upon the state of the PPs served by the FP, as explained in the subsections below. The hook status of the PacketCable single line client is dependant upon the hook status of the FP and the analog line as explained below. As such, the single line client has a composite view of the PPs as represented by the hook status of the FP. The PacketCable client MUST detect the hook status of the FP. The FP hook status detected by the single line client is on-hook when the PPs are either on-hook or involved in internal calls. The PacketCable single line client status is on-hook when the FP status is on-hook, and the analog line is also on-hook or in analog intrusion denial state.

6.4.1 Off-hook Transitions

The FP MUST detect an off-hook transition upon receipt of a valid CC-SETUP message from a PP for a call not destined to a device serviced by the FP, and containing the <<BASIC-SERVICE>> information element with a value of 88 indicating "wideband speech default setup attributes", but only when the current hook-state of the FP is on-hook. (Note that interoperability with other BASIC Services is out of scope, but not precluded from by this specification.) This is the case of a call origination or Barge-In from a PP. See Section 6.10 for a description of Barge-In.

The FP MUST detect an off-hook transition upon receipt of a valid CC-CONNECT message from a PP for a call not destined to a device serviced by the FP, but only when the current hook-state of the FP is on-hook. This is the case when a user answers an inbound call termination attempt at the PP.

The hook status of the FP transitions to the off-hook state when the FP detects an off-hook transition.

The PacketCable client MUST transition to off-hook status when an off-hook transition is detected by the FP and the current hook status of the PacketCable client is on-hook.

The PacketCable client MUST transition to off-hook status when an off-hook transition is detected at the analog interface and the current hook status of the PacketCable client is on-hook.

6.4.2 On-hook transitions

The FP MUST detect an on-hook transition upon receipt of a valid CC-RELEASE or CC-RELEASE-COM message from a PP for a call not serviced locally by the FP, but only if no other PP s are involved in the call to the network.

A PP may go out of range during a call, or other errors may occur during call setup or teardown. In any case, when the FP transitions to the "Null" call control state as defined in [EN 300 175-5] as a result, and no other PPs are involved in the call, then the FP MUST detect an on-hook transition.

The PacketCable single line client MUST transition to on-hook status when an on-hook transition is detected by the FP and the current hook status of the PacketCable client is off-hook and either the current hook status of the analog interface is on-hook or the current hook status of the analog interface is off-hook but in the analog intrusion denial state.

The PacketCable single line client MUST transition to on-hook status when an on-hook transition is detected at the analog interface and the current hook status of the FP is on-hook and the current hook status of the PacketCable client is off-hook.

6.5 Hook Flash Detection

The FP MUST detect a hook flash indication upon receipt of a valid DECT call control message from a PP for a call not destined to a device serviced by the FP, and containing the <<KEYPAD>> or <<MULTI-KEYPAD>> information element, with a control code of 15H. This indicates that the DECT defined "register recall" (or flash) key has been pressed on a PP not involved in an internal call.

The PacketCable client MUST detect hook flash indications from the FP. The PacketCable client MUST detect hook flash on the analog line per PacketCable specifications. A flash hook is generated normally when detected from an off-hook phone connected to the analog interface, but only if the endpoint is not in the analog intrusion denial state as described in Section 6.10 Barge-In.

6.6 Tone Generation

6.6.1 Local Tone Generation

The generation of any local tone is applied by the FP to all PPs involved in an in-process call or an established call not serviced locally by the FP. The FP MUST activate the DECT U-plane before the tone is generated. If the U-plane is not active when the request is received to apply the tone, then the FP MUST send a DECT call control message to all PPs involved in the call to establish the U-plane. The PacketCable Client MUST support the following local tones that can be sent to the PP:

- DTMF Tones
- Busy Tone
- Confirmation Tone
- Dial Tone
- Message Waiting Indicator Tone
- Off-hook Warning Tone
- Reorder Tone
- Ring Back Tone
- Stutter Dial Tone
- Call Waiting Tones

If configured to do so, the PacketCable client MUST play a wave file in lieu of a tone listed above. Requirements for tones applied to the analog line are defined in the PacketCable specifications.

6.6.2 Network Tone Generation

Network tone generation is unaffected by DECT.

6.7 Caller ID Delivery

When a valid request for Caller ID display is received, delivery depends on the current hook state of the endpoint. If the current state is on-hook, then the FP MUST attempt Caller ID delivery to all PPs successfully registered with the FP. Internal calls between PPs are possible during the on-hook status, such that Caller ID is delivered to the PPs on an internal call. If the current state is off-hook, then the FP MUST deliver Caller ID to only the PPs involved in the call to the network. Note that Caller ID on the DECT air interface can be delivered immediately, and does not need to wait for call waiting tone or ringing.

The FP MUST transmit Caller ID information to an individual PP by sending a valid DECT message with the <<CALLING-PARTY-NUMBER>> information element set to the value of the caller ID number provided and the <<CALLING-PARTY-NAME>> information element set to the value of the caller ID name provided.

If the caller ID number is "Private" or anonymous, then the FP MUST set the <Presentation Indicator> field to "Presentation restricted". If the caller ID number is "Out of Area" or not provided, then the FP MUST set the <Presentation Indicator> field to "Number not available". Otherwise, the FP MUST set the <Presentation Indicator> field to "Presentation allowed" as described in [EN 300 175-5].

If the caller ID name is "Private" or anonymous, then the FP MUST set the <Presentation Indicator> field to "Presentation restricted". If the caller ID name is "Out of Area" or not provided, then the FP MUST set the <Presentation Indicator> field to "Number not available". Otherwise, the FP MUST set the <Presentation Indicator> field to "Presentation allowed" as described in [EN 300 175-5].

If the hook status is on-hook with no network connections (other than for testing, or replication) on the FP at the time Caller ID delivery completes, and the call is not needed for the application of additional signals, then the FP MUST release the call over the DECT air interface to all PPs not involved in a call serviced locally as defined in [EN 300 444]. Network connections used for testing such as Loopback, or replication such as Busy Line Verification, are specified in PacketCable specifications normatively referenced by this document.

Caller ID time information can be provided by the PacketCable network signaling, or the time of day can be available on the PacketCable client. If the call time is available to the FP, the FP MUST send the call time in the <<TIME-DATE>> IE in an IWU-INFO message per [EN 300 444]. Note that the <<TIME-DATE>> IE does not map to the timestamp information received via network signaling. The network may provide Month/Day/Hour/Minute, whereas the IE includes Year/Month/Day, Hour, Min, Second, Timezone. Therefore, the FP MUST set the time zone, year, and seconds fields of the <<Time-Date>> IE to zero when sending the <<Time-Date>> to the PP. The FP does not send the <<Time-Date>> IE in an IWU-INFO message when the call time is not available to the FP. Furthermore, the calling party number and name can be delivered in other valid messages, such as a CC-SETUP, when call time is not available. The PP may have its own local time source.

The PP MUST provide a visible indication of calling party number, calling party name, and Caller ID time information when available.

6.8 Ring Generation

This section applies to all ring signals which may be applied on the endpoint which include the following:

- Distinctive Ringing
- Standard Ringing

- Ring Splash

When ringing is requested, the PacketCable single line client MUST apply the same ringing pattern on the FP and the analog line at the same time. When ringing is requested, the FP MUST send a valid DECT call control message to all successfully registered PPs not involved in a call serviced locally by the FP, containing the <<SIGNAL>> information element set to "ring on continuous". To control the cadence of the ring signal, the FP MUST send subsequent valid DECT call control messages to all PPs not involved in a call serviced locally by the FP containing the <<SIGNAL>> information element set to either "ring on continuous" or "ring off".

When ringing is initiated, a PP may be out of range or simply unregistered. If a PP comes into range and registers while the other PPs are being alerted, the FP MUST alert the newly registered PP with the rest of the PPs beginning on the next cadence update as described above.

When ringing is initiated, some PPs may be involved in an intercom call. If the users end the intercom call while the other PPs are being alerted, the FP MUST alert the PPs formerly involved in the intercom call with the rest beginning on the next cadence update as described above.

If the ring signal is applied for its full configured duration with no network connections (other than for testing or replication) on the endpoint at the time the ring signal completes, and the call is not needed for the application of additional signals, then the FP MUST release the call over the DECT air interface as defined in [EN 300 444] to all PPs not involved in a call serviced locally by the FP. Note that the ring signal generation is stopped (i.e., does not complete) if the DECT PP goes off-hook, and thus, the FP MUST NOT release the call. The FP then releases the call to the remaining PPs that did not answer the call.

6.9 VMWI Delivery

When a valid request for Voice Message Waiting Indication (VMWI) is received, the indication must be delivered to the registered PPs independently of the current hook status of the endpoint.

The FP MUST transmit VMWI information to each successfully registered PP by sending a valid DECT FACILITY message with the <<EVENTS-NOTIFICATION>> information element containing the event type set to "message waiting", the sub-type set to "voice message". In this case, the FP MUST condition the event multiplicity set to the total number of unread messages (when known) for VMWI on and condition the event multiplicity set to indicate zero unread messages for VMWI off. See the <<EVENTS-NOTIFICATION>> section of [EN 300 175-5].

The PP MUST provide a visible indication of VMWI when available.

6.10 Barge-In

Barge-In is a feature that allows any handset or the analog port on the same line to automatically join an existing call to a destination external to the FP. As such, Barge-In emulates POTS behavior for multiple analog phones connected to the same analog line. Barge-In leverages the DECT Implicit Intrusion capability as reflected in the requirements below. The PacketCable client MUST support Barge-In, which can optionally be enabled depending on service provider provisioning. The FP MUST support Barge-In, which optionally be enabled depending on service provider provisioning. The feature data table below depicts the data required for Barge-In provisioning.

Table 9 - Barge-In Feature Data

Data	Type	Persistence	Default Value	Range	Scope	Provisioning Requirement
Barge-In	Boolean	Volatile	True	True/false	Per FP and PacketCable client pair	Mandatory Read-Write

When Barge-In is provisioned to be disabled by the operator (i.e., set to value 'false'), the FP MUST provide an audible indication (for example, reorder tone, busy tone or locally provisioned wave file) to a PP that goes off-hook during an existing call from a PP or the analog line to the network.

"Analog intrusion denial" is defined to be a logical state in which a user goes off-hook on an analog phone, in an attempt to intrude onto a call that is already in progress using a DECT PP, and the PacketCable client and FP are configured to allow intrusion only via request (Barge-In is disabled). When Barge-In is provisioned to be disabled by the operator (i.e., set to value 'false'), the PacketCable client MUST provide an audible indication (for example, reorder tone, busy tone or locally provisioned wave file) to an analog phone that goes off-hook during an existing call. The analog phone user is not allowed to join or interrupt the call in progress. For example, hook transitions and DTMF tone events are not generated from the analog line when in intrusion denial, and do not impact the existing call.

Upon receipt of a valid CC-SETUP message containing the <<BASIC-SERVICE>> information element with a value of 88 indicating "wideband speech default setup attributes" (per [TS 102 527-1] and [EN 300 444]) from a PP during an existing external call at the FP and PacketCable client, and the FP is provisioned for Barge-In as shown in Table 9, the FP MUST provide an audio bridge (or conference) between the PP and the existing call at the FP as specified in the implicit call intrusion procedures of [TS 102 527-3].

When the analog line goes off hook during an existing external call, and the PacketCable client and FP are provisioned for Barge-In, as shown in Table 9, the PacketCable client MUST provide an audio bridge (or conference) between the analog line and the existing call at the FP.

Upon receipt of a valid CC-SETUP message containing the <<BASIC-SERVICE>> information element with a value of 88 indicating "wideband speech default setup attributes" per [TS 102 527-1] and [EN 300 444] from a PP during an existing call at the FP, and the PacketCable client and FP are not provisioned for Barge-In as shown in Table 9, the FP MUST provide an audible indication to the PP. The user is provided an in-use indication and may then request to join the existing call. Furthermore, upon an explicit call intrusion request from the PP, the FP MUST execute explicit call intrusion procedures per [TS 102 527-3].

When the analog line goes off-hook during an existing external call, and the PacketCable client and FP are not provisioned for Barge-In as shown in Table 9, the PacketCable client MUST place the analog line in the Analog Intrusion Denial state such that:

- Hook events are not generated when detected (i.e., on-hook, off-hook and hook flash).
- DTMF tones detected at the analog interface are ignored.
- The PacketCable client provides audible indication on the analog line.
- Media received from the analog line by the PacketCable client is discarded and is not joined into the existing call media.
- Media packets of the existing call are not passed from the PacketCable client to the analog line.
- Modem, fax and TDD tones detected on the analog line are ignored.

When the existing call terminates while the analog line is in the Analog Intrusion Denial state, the client hook status transitions to on-hook; however, there is no change in state on the analog line. The user needs to place the analog phone on-hook to clear the analog intrusion denial state on the analog line. The PacketCable client MUST clear the analog intrusion denial state when the user places the analog phone on-hook.

6.11 Internal Call Requirements

DECT specifies an intercom call function that allows a PP to establish an internal call to another PP at the same base station. This section includes requirements for internal calls, and also specifies interaction between incoming external calls while internal calls are in progress. When an incoming call is received during an existing internal call, and the state of the PacketCable client is on-hook, the FP MUST ring all idle handsets. The FP also MUST send an IWU-INFO message with caller ID information to the in-use handsets if caller ID is provided. When an incoming call is received during an existing internal call, and the state of the PacketCable client is on-hook, the PacketCable client MUST ring the analog line. Idle phones are able to answer the incoming call, so that the external call is established in parallel to the internal call. Phones in use need to release the internal call per DECT, before the PP can ring and then answer the incoming call.

The FP and PPs MUST support Internal Calls as specified in [EN 300 444] and [TS 102 527-3].

When the FP is required to alert the end user, i.e., apply ringing during an active internal call or calls, the FP MUST:

- Apply ringing to all idle PPs.
- Send an incoming call indication to the PPs that are currently active in an internal call.

The PacketCable client MUST apply ringing to the analog line when the client hook status is on-hook, including when the FP is serving internal calls between PPs. The FP MUST support an idle PP going off-hook to answer an incoming external call, and thus establish an external call while other PPs are involved in internal calls. The PacketCable client MUST support an idle analog phone going off-hook to answer an incoming external call, and thus establish an external call even while PPs are involved in internal calls.

6.12 Service Status

PacketCable specifications define how the service provider can enable or disable the PacketCable Customer Premise Equipment (CPE). For example, PacketCable 1.5 specifications include mechanisms to enable or disable the E-MTA, including the analog access line. These provisioning requirements also apply to PacketCable DECT devices. The PP should provide an indication to the user when the service provider disables service to help indicate the reason for a lack of dial tone. The FP MUST send a service provider configurable text string as shown in Table 10 within the <<MULTI-DISPLAY>> IE of a FACILITY message to each PP when service is disabled by the service provider.

PacketCable specifications detail how a PacketCable client detects when service is not available due to loss of network connectivity. Upon detection of loss of connectivity to the PacketCable network, the FP MUST send a service provider configurable text string as shown in the Table 10 within the <<MULTI-DISPLAY>> IE of a FACILITY message to each registered PP.

When PacketCable service transitions back to active service, the FP MUST clear the service status indication to each PP. The FP MUST NOT send the <<MULTI-DISPLAY>> IE when the value is set to null.

Table 10 - Service Status Feature Data

Data	Type	Persistence	Default Value	Range	Scope	Provisioning Requirement
Service –Deactivation Display	String	Volatile	Service Deactivated	N/A	Per FP	Mandatory Read-Write
Network Connectivity Display	String	Volatile	Network Unavailable	N/A	Per FP	Mandatory Read-Write

The PP MUST provide a visible indication of Service Deactivation and Network Connectivity as shown in Table 10 when available.

6.13 VoIP Metrics Package Interoperability for DECT

VoIP Metrics defined in PacketCable 1.5 and PacketCable 2.0 account for overall network performance and voice quality parameters on the entire VoIP path. Unless otherwise noted below, DECT-capable PacketCable devices (such as E-MTA, E-DVA and S-DVA) MUST support the VoIP metrics reporting requirements defined by the corresponding PacketCable specifications.

Currently, PacketCable specifications define voice quality measurement procedures for the narrowband (NB) codecs only. Voice quality measurements for wideband codecs are still being investigated by various industry bodies and thus not all measurements are utilized by PacketCable. The following sections provide additional details and requirements for DECT-capable PacketCable devices with respect to providing voice metrics. Detailed descriptions of each of the metrics can be found in [RFC 3611].

6.13.1 Packet Loss and Discard

Packet loss and discard metrics are based on RTP measures and are unaffected by the addition of a DECT interface or the use of a wideband codec.

6.13.2 Delay Metrics

Delay metrics include round trip delay and end system delay. Round trip delay is not impacted by the addition of the DECT interface or the use of a wideband codec.

End system delay continues to be reportable by the FP and is not impacted by the addition of the DECT interface. In particular, the FP is able to determine the instantaneous jitter buffer setting. The codec delay is a constant adder which, when the PP is matched to the FP, can be one of a number of hard-coded fixed values, one value for each supported codec type. When the PP is not known to the FP, the adder can be estimated based on the codec used over the Generic Access Protocol (GAP). Additional details can be found in [EN 300 175-8], Annex F.

6.13.3 Signal Metrics

The signal metrics block consists of Signal Level, Noise Level, and Residual Echo Return Loss. The ability to measure these parameters is impacted by the placement of signal processing functions across the DECT air interface as the GAP includes no ability for the PP to report signal and noise levels to the FP and has only a limited means of transferring a residual echo return loss value. For the purpose of these measurements, the necessary signal processing functions are typically provided in the echo canceller.

[EN 300 175-8] specifies that the FP MUST provide echo control if $TCLw < 46dB$ and shall not if $TCLw$ is $> 55dB$. This means that echo cancellers may be built into the FP but only when the $TCLw$ of the PP is $< 55dB$. However, [EN 300 175-8] also specifies a $TCLw$ of 55 dB for VoIP-compatible PPs. This means that a DECT FP

for VoIP would only include an echo canceller if it was designed to improve audio performance for PPs that were not designed for VoIP. Given this, the following requirements are provided for DECT-capable PacketCable devices:

- Where the DECT-capable PacketCable device receives echo parameter flags from the PP indicating the TCLw of the PP is > 55dB, any echo canceller in the FP MUST be deactivated and the residual echo return loss in its RTCP-XR metrics MUST be set to 55dB. The client SHOULD set the RTCP-XR signal and noise measurements to undetermined (127) unless actual values can still be measured (either in the FP or in the PP and reported to the FP).
- Where the DECT-capable PacketCable device receives echo parameter flags from the PP indicating the TCLw of the PP is < 55dB and as a result activates an echo canceller to control echo from the PP, the client SHOULD provide the actual measured values of residual echo return loss, signal, and noise.
- Where the DECT-capable PacketCable device receives echo parameter flags from the PP indicating the TCLw of the PP is < 42dB and as a result activates an echo suppressor to control echo from the PP, the client MUST set the residual echo return loss in the RTCP-XR metrics to 126dB. Since the signal level determines the echo suppressor operation, the FP SHOULD provide the actual value in the RTCP-XR metrics. The FP SHOULD set the noise level to undetermined (127) in the RTCP-XR metrics unless the actual value can be measured.
- Where the DECT-capable PacketCable device without an echo canceller receives echo parameter flags from the PP indicating the TCLw of the PP is > 46dB but < 55dB, any echo suppressor in the FP MUST be deactivated and the residual echo return loss in the RTCP-XR metrics SHOULD be set to 46dB. The client SHOULD set the signal and noise measurements to undetermined (127) in the RTCP-XR metrics unless actual values can still be measured.
- Where the DECT-capable PacketCable device without any echo control device (canceller or suppressor) receives echo parameter flags from the PP indicating the TCLw of the PP is < 46dB, the client SHOULD set the residual echo return loss in the RTCP-XR metrics to 42dB. The client SHOULD set the signal and noise measurements to undetermined (127) in the RTCP-XR metrics unless actual values can still be measured.

Note that DECT FPs that rely on the PP for good echo control and so do not include any echo control device are not required to read the echo parameter flags. Where the DECT-capable PacketCable device does not read the echo parameter flags, the PacketCable client MUST set the residual echo return loss in the RTCP-XR metrics to undetermined (127).

6.13.4 Call Quality

The call quality metrics block consists of the R factor, external R factor, MOS-LQ, and MOS-CQ. Of this, the PacketCable 1.5 and 2.0 codec specs require that R factor, MOS-LQ, and MOS-CQ metrics be reported. The reporting of the external R factor is optional. However, the addition of the DECT interface or the use of a wideband codec impacts the device's ability to report call quality metrics as described in the next paragraphs.

6.13.4.1 DECT Interface

When using the DECT interface for a narrowband session, at a minimum, the Packet Loss, Discard and Delay blocks can be reported. Within the signal metrics block, only RERL can be reported in all cases and Signal and Noise Level only in a small number of scenarios. Given that the call quality metrics rely on the signal and noise metrics for the calculation of the R factor and associated MOS metrics, if the signal and noise metrics are not reportable, then the PacketCable client MUST report the R factor, MOS-LQ, and MOS-CQ as unavailable (127).

6.13.4.2 Wideband Codec

For the use of a wideband codec over the DECT interface, the requirements in Section 6.13.4.1 above apply. Additionally, if the signal and noise level metrics are available, the PacketCable client MUST report the R factor, MOS-LQ, and MOS-CQ as unavailable (127). This is necessary given the E-Model formulas defined in ITU-T G.107 have not been fully updated for wideband codecs.

6.14 Emergency Services

Emergency service requirements over the DECT air interface are out of scope for this document. Emergency calls on the air interface can be seen as normal calls by the PP and FP. The PacketCable client MUST support emergency call procedures defined in PacketCable specifications. The support for an emergency call from a PP that is not registered with the FP is out of scope for this document.

6.15 Operator Services

Operator service requirements follow existing PacketCable specifications and do not apply to DECT intercom service. The PacketCable client MUST support operator service requirements defined in PacketCable specifications.

6.16 Fax, Modem and TDD Interoperability for DECT

Fax, modem, and TDD support over the DECT air interface are out of scope for this document. The support for ITU-T T.38, V.152, and TDD, on the analog port, are specified in the PacketCable specifications referenced in this document.

6.17 IP Transparent Data Services

The FP MUST support IP transparent packet data as specified in [TS 102 527-2], and be upgradable to 128Kbps.

6.18 Security

DECT provides a series of authentication and encryption capabilities on the air interface. The FP MUST support the mandatory authentication and encryption capabilities mandated in the GAP specification [EN 300 444]. The PP MUST support the mandatory authentication and encryption capabilities in the GAP specification [EN 300 444]. See PacketCable specifications for security requirements mandated on to the PacketCable network.

6.19 Provisioning

The operator determined feature data defined in this specification are provisioned per the requirements contained in the [DECT-PROV] Specification. The [DECT-PROV] Specification considers the different provisioning mechanisms applied to embedded devices (E-MTA, E-DVA) versus stand alone (S-DVA) devices.

The FP MUST support the provisioning requirements as specified in [DECT-PROV].

The PacketCable client MUST support the provisioning requirements as specified in [DECT-PROV].

6.20 Interoperability with Legacy Home Alarm Systems

Home alarm systems need to immediately place calls to an alarm system provider central monitoring station in order to report security events whenever events are detected. A Legacy Home Alarm System described in this section is a system which uses the analog telephone lines to report the alarm events regardless of the types of the sensors used to register the alarm events. All other types of the alarm systems (types of the network interfaces and alarm events reporting mechanisms) are outside of scope of this specification. The alarm system call may need to preempt

existing calls from the home as needed to report the security alarm event. As such, legacy home alarm systems are often configured in series between the telecommunications service provider interface and the home analog line connected to analog phones. The alarm system electrically disconnects the analog phones when it calls out to an alarm system provider, thus immediately pre-empting any existing calls on the analog phones.

The integration of a DECT FP with a PacketCable client that also supports an analog line raises new implications for how an alarm system places immediate calls to an alarm monitoring center in the presence of existing calls with DECT PPs. This specification places requirements on the PacketCable client in the presence of DECT that enable legacy home alarm systems to immediately place calls to a central monitoring station. Two alternative approaches are specified below. The PacketCable client MUST support at least one of the approaches defined in Sections 6.20.1 and 6.20.2.

Note that an operator could choose to provision a dedicated line and directory number for the legacy alarm system. This is an operational configuration that does not introduce additional requirements on the PacketCable client, and therefore, is out of the scope of this specification.

6.20.1 Preemption for the Alarm System

Preemption for the alarm system is needed when the PacketCable client supports one or more analog lines and an FP that are assigned to the same directory numbers, and only one active call is possible to the network. In this case, the operator provisions one analog interface to be preemptive. The preemptive interface is intended to be connected to the legacy alarm system. Analog phones and data devices can be connected to separate analog line served by the PacketCable client. Calls from the preemptive analog line automatically preempt existing calls from the FP or other analog lines supported by the client that share the same directory number. The characteristics of the analog interface are defined by other PacketCable specifications such [AIP1.5] or [E-DVA]. This specification places requirements on the PacketCable client in order to execute preemption for alarm system calls.

The PacketCable client MUST support one or more analog lines and the FP that all share the same directory number and are seen as a single line to the network.

The PacketCable client MUST be able to identify an analog interface to be preemptive if provisioned by the service provider as shown in Table 11 below. The PacketCable client MUST report the alarm system configurations methods it supports as shown in Table 11 below.

Table 11 - Analog Line Configuration for Alarm Systems

Data	Type	Persistence	Default Value	Range	Scope	Provisioning Requirement
Alarm System configuration as provisioned	Enumerated List	Volatile	Value is equal to the method implemented by the client, or equal to preemptive if multiple methods are implemented	1 = no ports are for the alarm system 2 = analog port 1 is preemptive 3 = analog port 1 is for alarm system simultaneous calls	Per PacketCable client	Mandatory Read-Write
Alarm System configuration supported	Enumerated List	Non-volatile	Value is equal to the method implemented by the client, or equal to preemptive if multiple methods are implemented	1 = preemptive port supported 2 = simultaneous calls supported 3 = preemptive port and simultaneous calls supported	Per PacketCable client	Mandatory Read only

The PacketCable client MUST NOT execute Barge-In as defined in Section 6.10 on an analog line designated as preemptive.

Upon detecting an off-hook transition on the preemptive analog line, the PacketCable client MUST release any existing calls with the FP. In this case, the FP then MUST release the call to the PPs per Normal Call Release and Abnormal Call Release procedures defined in [EN 300 444].

Upon detecting an off-hook transition on the preemptive analog line, the PacketCable client MUST release or terminate any existing call to the PacketCable network associated with the same directory number assigned to the preemptive alarm line. As part of releasing the existing call to the network, the PacketCable client MUST first present an on-hook status to the network to clear any existing call state prior to transitioning to off-hook in order to service the call request from the preemptive analog line. After presenting the initial on-hook status, and then off-hook status, the PacketCable client MUST perform call origination establishment procedures as defined in PacketCable specifications for the preemptive line.

Upon detecting an off-hook from the preemptive analog line, the PacketCable client MUST place all other analog lines that share the same directory number as the preemptive analog line in analog intrusion denial state as described in Section 6.10.

While the preemptive analog line is off-hook, the PacketCable client MUST reject service requests from the FP toward the network that are associated with the same directory number assigned to the preemptive analog line.

Note that the configuration described in this section does not prevent an operator from connecting the alarm system in series between the client pre-emptive analog interface and traditional analog phones. If done so, off-hook transitions from the analog phones will be detected at the preemptive interface and may cause the preemption of calls from the FP and other analog lines that share the same directory number. The analog intrusion state is cleared when the preemptive line goes on hook.

6.20.2 Simultaneous Calls for the Alarm System

Simultaneous call support for the alarm system is needed when the PacketCable client supports one or more analog lines and an FP that are assigned to the same directory number, and are seen as a single provisioned line by the network. Only one active call is normally possible amongst the FP, analog lines and the network, except in the case of an alarm system call request that is processed in parallel with an existing call. In this case, the operator provisions one analog interface for the alarm system. Other analog lines can be used to support analog phones or data devices. Calls from the alarm system analog line are immediately established and can occur simultaneously with existing calls from the FP or other analog lines supported by the client that share the same directory number. The characteristics of the analog interface are defined by other PacketCable specifications such as the E-DVA. This specification places requirements on the PacketCable client in order to support simultaneous calls from the alarm system.

Requirements in this section apply only to PacketCable 2.0 clients.

The PacketCable client MUST support one or more analog lines and the FP that all share the same directory number and are seen as a single line to the network.

The PacketCable client MUST be able to identify an analog interface to be for the alarm system simultaneous calls if provisioned by the service provider as shown in Table 11 above.

The PacketCable client MUST NOT execute Barge In as defined in Section 6.10 on an analog line provisioned for the alarm system simultaneous calls.

Upon detecting an off-hook transition on the analog line provisioned for alarm system simultaneous calls, the PacketCable client MUST support PacketCable call origination establishment procedures separate for the alarm system, even if the alarm system call is simultaneous with other existing calls with the network. The PacketCable client MUST NOT allow events (such as on-hook or hook-flash) from the FP or other analog lines to impact the call established for the alarm system.

6.21 Network-Based Call Screening

Network-Based Call Screening (NBCS) emulates answering machine screening by linking network voice mail to the FP and the PP. The user can activate or deactivate NBCS via appropriate user interfaces on the FP and the PP.

Prior to NBCS feature execution, an incoming call is received and is to be forwarded to voice mail by either:

- Call Forwarding Don't Answer CFDA when a user does not answer the call, or
- Call Forwarding Variable (CFV) when a user directs all incoming calls to voice mail.

NBCS feature is initiated upon the network's decision to redirect a call forwarded by CFDA or CFV to voice mail. As part of the NBCS feature execution, the PacketCable client establishes a receive-only audio that contains the Voice Mail Server (VMS) prompts and the caller responses as voice message is being recorded. Upon receiving the indication from the PacketCable client that NBCS has been initiated by the network, the FP MUST render the receive-only audio to its speaker if the speaker is available and NBCS was previously activated on the FP by the user (via a mechanism that is outside the scope of this specification). In addition, the FP MUST send a CC-SETUP message to each PP that is associated with the destination address of the original call, with the message being formatted as for a basic call (Section 7.1) with the following additional requirements:

- The CC-SETUP message includes the Caller ID associated with the original call that triggered the NBCS feature.
- The CC-SETUP message includes a <<CALLED-PARTY-SUBADDRESS>> IE, with the Subaddress Type field set to "User Specified" and the Subaddress Information field set to the Binary Coded Decimal (BCD) value of decimal digits "01".

The <<CALLED-PARTY-SUBADDRESS>> IE in CC-SETUP indicates to the PP that NBCS has been initiated and that a receive-only audio path is to be established. Upon receiving such a CC-SETUP message, the PP MUST NOT alert the user. The PP MUST render the receive-only audio to the speaker without user intervention.

The user may answer the call that is being recorded via appropriate user interface on any PP that is playing the audio. In this case, the PP MUST send a CC-INFO message to the FP with a <<KEYPAD>> or <<MULTI-KEYPAD>> IE that has a value for Register Recall as defined in Section 6.5. This indicates to the FP that the user has answered the call. Upon receiving the CC-INFO message, and the FP MUST establish a two-way path between the PP and the calling party via the PacketCable client. At this point, the VMS is dropped out of the audio path. In addition, the FP MUST release the connection (as defined in Section 7.11) with any other PP that was sent the CC-SETUP in the current NBCS session.

Alternatively, the user may answer the call that is being recorded via appropriate user interface on the FP. In this case, the VMS is dropped out of the audio path and a two-way path is established between the FP and the calling party. In addition, the FP MUST release the connection (as defined in Section 7.11) with every PP that was sent the CC-SETUP in the current NBCS session.

The NBCS feature can be activated or deactivated for a particular PP or for the FP by the user via a mechanism that is outside the scope of this specification.

Figure 5 shows a basic example call flow for the NBCS feature.

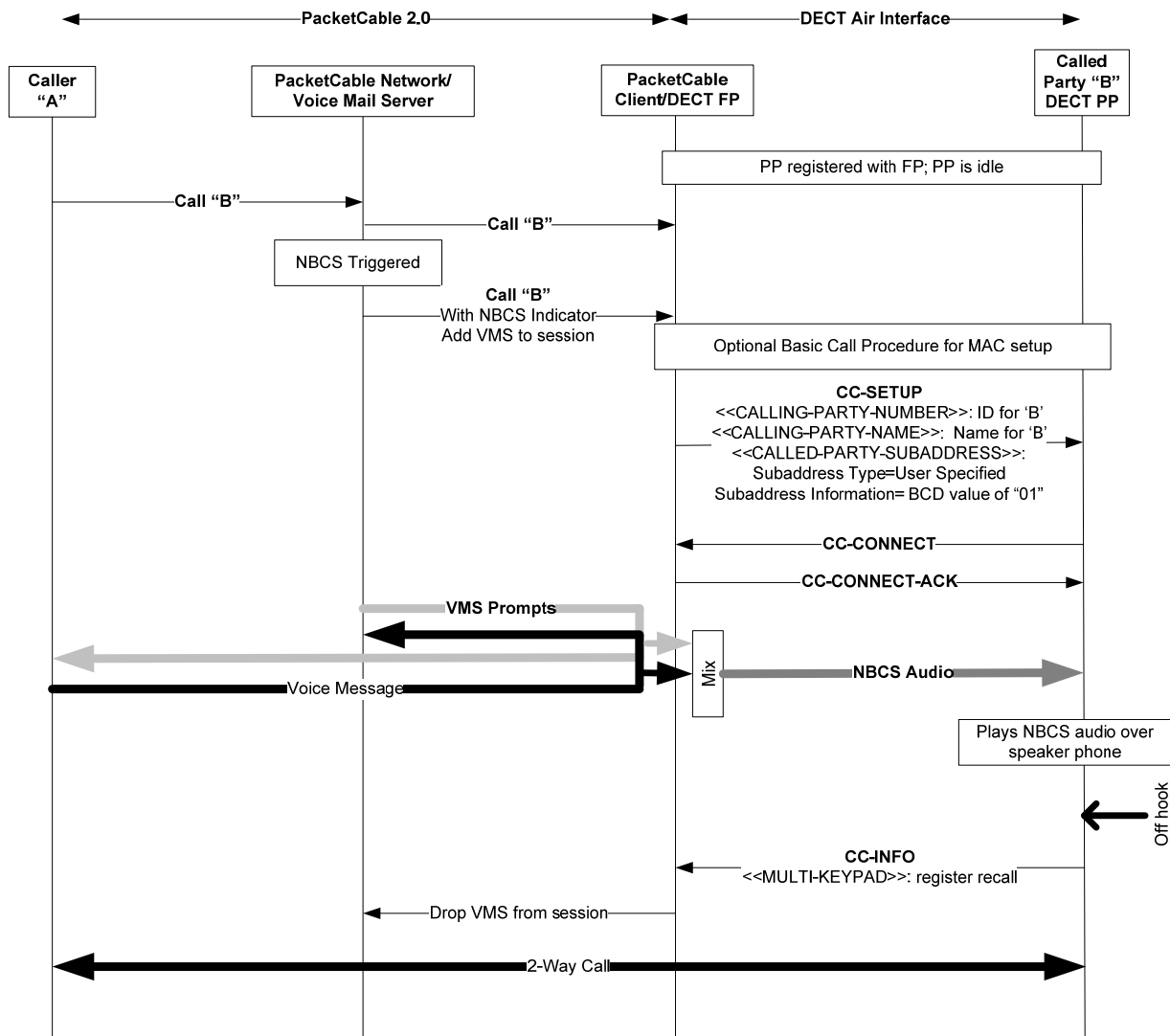

Figure 5 - Network Based Call Screening Call Flow Example

6.22 Multi-line Support

The Multi-line feature associates multiple directory numbers (DN) with a HD Voice client device. In particular, it supports the mappings between these DNs and various PPs that are registered with the FP within the client device.

In order for the user to configure mappings between the DNs and the PPs, the FP MUST support the List Access feature and the following lists specified in [TS 102 527-3]: List of Supported Lists, Internal Names List, Line Settings List, and DECT System Settings List.

In order to support the provisioning of the Multi-line feature from the network side, the PacketCable client supports the corresponding requirements in [DECT-PROV].

The Multi-line feature does not require the support of Parallel Calls feature specified in [TS 102 527-3]. However, the FP MUST support the Line Identification feature in [TS 102 527-3].

For an external inbound call, the FP maps the called DN to a set of associated PPs, as described in [DECT-PROV]. The following cases can arise, depending on the statuses of these associated PPs:

- All associated PPs are idle. In this case, the FP MUST set up a call with the associated PPs by following the single-line requirements specified in the other subsections of Section 6. Furthermore, in the CC-SETUP message, the FP MUST include the external line identifier information in <<CALL-INFORMATION>> IE, as specified in [TS 102 527-3] for Line Identification feature. This line identifier is mapped from the called DN, as described in [DECT-PROV].
- At least one of the associated PPs is in use on the same line as the called DN. In this case, the FP MUST NOT alert the idle PPs that are associated with the called DN. The PacketCable client invokes the single-line call-waiting procedure for the PPs that are currently in use on the same line as the called DN.
- A PP that is associated with the called DN is in use on a line different from the called DN. In this case, the handling of the second call by the FP is outside the scope of this specification.

For an external outbound call, the PP MAY provide the line identifier for the call in <<CALL-INFORMATION>> IE or <<MULTI-KEYPAD>> IE as part of call setup, as specified in [TS 102 527-3] for Line Identification feature. If the line identifier is not provided by the PP, the FP MUST select the line for the call according to the provisioning policy [DECT-PROV]. With the line selected for the outbound call, the PP and FP follow the single-line requirements for the call origination, using the DN corresponding to the selected line identifier as the originating address.

When the network provides the PacketCable client with a Message Waiting Indicator (MWI) for a called DN, the FP MUST notify all the PPs that are associated with the DN about the MWI, as described in Section 6.9. In the message for MWI event-notification, the FP MUST include the line identifier for the called DN in <<CALL-INFORMATION>> IE.

7 DECT MESSAGES

This section describes the interaction between the PacketCable network and the DECT messages transmitted between the FP and PP, as specified in [TS 102 527-1] and [EN 300 444]. Only messages and associated functionally relevant for PacketCable interoperability are addressed. Mapping between the PacketCable network and DECT interface is described. Additional functionality provided by DECT is not prohibited, but is out of scope of this specification.

Most of the functionality described below is mandated by [EN 300 444] or [TS 102 527-1], and further defined in [EN 300 175-5]. In some cases, the functionality is specified to be optional in DECT, but is mandatory in PacketCable to insure interoperability between the FP and PP. Requirements on the U-plane are one example where PacketCable mandates functionality that is optional in DECT. The FP MUST establish the U-plane as soon as possible during call setup, to allow the FP to provide tone generation over the DECT air interface to the PP when necessary. This also helps to prevent media clipping when cut through over the network has been established. Enabling the U-plane via a DECT response message also prevents the PP from generating local tones on its own.

In some regards, call setup over the DECT interface is independent of connection (or call) setup over the PacketCable network. As such, much of the DECT message exchange is performed independently of network protocol signaling. The receipt of a DECT message from the PP, for example, may initiate a network-based message. But the response to the DECT message is not contingent on the success or failure of the network-based message.

[EN 300 444] states that overlap sending support is optional on the FP; however, the FP MUST support overlap sending. The PP MUST support overlap sending.

It is recommended that PacketCable network responses from the FP are not delayed or contingent upon DECT air interface signaling. For example, an INVITE may trigger both a 100 on the network and a SETUP up on the air interface. In this case, the 100 on the network is not delayed waiting upon DECT air interface actions.

7.1 CC-SETUP

The PP sends a CC-SETUP message, as defined in the procedures for Outgoing Call Request as defined in [EN 300 444], to indicate that a user has taken the handset off-hook and a potential call origination is being initiated. See Section 6.4 for requirements related to the hook status due to an indication from the PP for an outbound call origination (not intercom call).

The FP MUST respond to a valid CC-SETUP message according to the procedures defined for Overlap Sending in [EN 300 444] and include within the response the <<PROGRESS-INDICATOR>> information element with a value of 8 to enable the U-plane. The FP MUST not delay the sending of the response message or make it contingent upon any PacketCable network protocol message transmitted as a result of receiving the CC-SETUP message.

The CC-SETUP message is also used by the FP to setup a call over the DECT interface as defined in the procedures for Incoming Call Request in [EN 300 444]. The FP MUST include the <<PROGRESS-INDICATOR>> information element with a value of 8 to enable the U-plane if the resources are available on the air interface. It is advised to open the U-plane as soon as possible during call establishment in order to help ensure initial audio packets are delivered.

The CC-SETUP message may also be used to initiate ringing and/or display Caller ID. See Section 6.7 for more information on delivering Caller ID and Section 6.8 on ring signal generation for more information on alerting PPs.

Refer to Section 6.2.1 on Codec Negotiation for requirements on setting up the codec used over the DECT air interface.

7.2 CC-SETUP-ACK

The CC-SETUP-ACK is used by the FP as described in the Overlap Sending procedures in [EN 300 444].

7.3 CC-INFO

DECT specifications allow the FP and PP to send CC-INFO messages for various reasons during and after call establishment. The CC-INFO message from the PP may contain the <<KEYPAD>> or <<MULTI-KEYPAD>> information element. Processing of the information depends on the contents. For DTMF digits see Section 6.3. For Register Recall (15H) see Section 6.5.

The CC-INFO message may be used by the FP to control PP alerting as described in Section 6.8 or delivering Caller ID as described in Section 6.7.

Neither the FP nor the PP is required to respond upon receipt of a CC-INFO message.

7.4 CC-ALERTING

The CC-ALERTING message is used by the PP as described in the procedures for Incoming Call Confirmation in [EN 300 444] after PP alerting is initiated by the FP. See Section 6.8 for more information on alerting.

The FP MUST follow the procedures outlined in [EN 300 444] for Outgoing Call Confirmation when required to apply local ring back tone and the outgoing call has not yet been fully established over the DECT interface (i.e., the call has not yet been "connected"). This is an indication to the PP that the far end is being alerted.

Ring back tone may be provided via early media from the far end during call setup. The FP, therefore, is not required to generate local ring back tone. In this case, the FP MUST NOT follow the procedures outlined in [EN 300 444] for Outgoing Call Confirmation. This is to prevent mixed messages at the PP since it is possible that the far end is a media server playing a message back to the PP instead of ring back tone. The FP is unable to distinguish between these two scenarios.

7.5 CC-CONNECT

The CC-CONNECT is used by the PP as described in the Incoming Call Connection procedures in [EN 300 444]. The FP responds as described in the Incoming Call Connection procedures. The FP MUST NOT delay the sending of the response message contingent upon any PacketCable network protocol message transmitted as a result of receiving the CC-CONNECT message. See Section 6.4 for requirements related to the hook status.

The FP uses the CC-CONNECT as described in the Outgoing Call Connection procedures in [EN 300 444]. The FP MUST follow the Outgoing Call Connection procedures when all of the following conditions are met:

- A DECT call has been initiated from the PP but has not yet been established.
- The call results in the creation of a network connection for the purpose of serving an outbound call.
- Local ring back tone is not being applied.
- The remote SDP has been obtained for the connection created and media is expected to be sent and/or received to/from the user interface (analog and DECT).

7.6 CC-CONNECT-ACK

The CC-CONNECT-ACK is used by the FP as described in the Incoming Call Connection procedures in [EN 300 444]. This message is also used by the PP in the external handover procedure.

7.7 CC-SERVICE-CHANGE

The CC-SERVICE-CHANGE message is used by the FP as described in the Codec Change procedures in [TS 102 527-1].

7.8 CC-SERVICE-ACCEPT

The CC-SERVICE-ACCEPT message is used by the PP as described in the Codec Change procedures in [TS 102 527-1].

7.9 CC-SERVICE-REJECT

The CC-SERVICE-REJECT message is used by the PP as described in the Codec Change procedures in [TS 102 527-1].

7.10 IWU-INFO

DECT specifications allow the FP and PP to send IWU-INFO messages for various reasons. This message is also used by the PP and FP as described in the Codec Change procedures in [TS 102 527-1].

7.11 CC-RELEASE

The PP sends a CC-RELEASE message as per the procedures defined for Normal Call Release and Abnormal Call Release in [EN 300 444]. The FP responds accordingly. The FP MUST not delay the sending of the response message contingent upon any PacketCable network protocol message transmitted as a result of receiving the CC-RELEASE message. See Section 6.4 for requirements related to the hook status.

The FP also sends a CC-RELEASE message as per the procedures defined for Normal Call Release and Abnormal Call Release in [EN 300 444].

7.12 CC-RELEASE-COM

The CC-RELEASE-COM is used by the PP and FP as described in the Normal Call Release and Abnormal Call Release procedures in [EN 300 444]. See Section 6.4 for requirements related to the hook status.

7.13 FACILITY

The DECT specifications allow the PP and FP to send FACILITY messages to request and acknowledge supplementary services. The FACILITY message is also used to deliver Visual Message Waiting Indicator information as described in Section 6.9.

Appendix I Acknowledgements

The PacketCable team wishes to recognize the following individuals for their significant involvement and contributions to this specification (ordered alphabetically by company name and individual's first names in each company):

Billy Hare, Arris (Lead Author)

Eugene Nechamkin, Broadcom

Gordon Li, Broadcom

Effi Shiri, DSP Group

Dave Ellis, Motorola

Jerry Mahler, Motorola

Mark Trayer, Samsung

Oliver Maiwald, SiTel

The following CableLabs staff is thanked for their contributions that helped us improve this specification in various ways: David Hancock, Jean-Francois Mule, Kevin Johns, Eduardo Cardona and Stuart Hoggan.

Sandeep Sharma, Bernie McKibben and the PacketCable Architecture Team (CableLabs)

Appendix II Revision History

The following Engineering Change Notices were incorporated into PKT-SP-DECT-HDV-I02-090917.

ECN	Date Accepted	Summary
DECT-HDV-N-09.0567-2	6/22/09	Add support for the Network based call screening feature
DECT-HDV-N-09.0578-3	6/29/09	Provide a summary of features mandated from the CAT-iq (ETSI DECT) profiles
DECT-HDV-N-09.0579-2	6/22/09	Changes due to withdrawal of PACM and 33.220 delta spec (GBA)