

PacketCable™

Residential SIP Telephony E-DVA Specification

PKT-SP-RST-E-DVA-I01-060927

ISSUED

Notice

This PacketCable specification is a cooperative effort undertaken at the direction of Cable Television Laboratories, Inc. (CableLabs®) for the benefit of the cable industry. Neither CableLabs, nor any other entity participating in the creation of this document, is responsible for any liability of any nature whatsoever resulting from or arising out of use or reliance upon this document by any party. This document is furnished on an AS-IS basis and neither CableLabs, nor other participating entity, provides any representation or warranty, express or implied, regarding its accuracy, completeness, or fitness for a particular purpose.

© Copyright 2006 Cable Television Laboratories, Inc.
All rights reserved.

Document Status Sheet

Document Control Number:	PKT-SP-RST-E-DVA-I01-060927			
Document Title:	Residential SIP Telephony E-DVA Specification			
Revision History:	I01- Released 9/27/06			
Date:	September 27, 2006			
Status:	Work in Progress	Draft	Issued	Closed
Distribution Restrictions:	Author Only	CL/Member	CL/Member/Vendor	Public

Key to Document Status Codes:

- Work in Progress** An incomplete document, designed to guide discussion and generate feedback that may include several alternative requirements for consideration.
- Draft** A document in specification format considered largely complete, but lacking review by Members and vendors. Drafts are susceptible to substantial change during the review process.
- Issued** A stable document, which has undergone rigorous member and vendor review and is suitable for product design and development, cross-vendor interoperability, and for certification testing.
- Closed** A static document, reviewed, tested, validated, and closed to further engineering change requests to the specification through CableLabs.

Trademarks:

DOCSIS®, eDOCSIS™, PacketCable™, CableHome®, CableOffice™, OpenCable™, OCAP™, CableCARD™, M-CMTS™, and CableLabs® are trademarks of Cable Television Laboratories, Inc.

Contents

1	SCOPE	1
1.1	Introduction and Purpose.....	1
1.2	Requirements.....	1
2	REFERENCES	2
2.1	Normative References	2
2.2	Informative References	3
2.3	Reference Acquisition	4
3	TERMS AND DEFINITIONS	5
4	ABBREVIATIONS AND ACRONYMS	6
5	OVERVIEW	7
5.1	PacketCable Overview	7
5.2	Service Goals.....	7
5.3	PacketCable Reference Architecture	7
5.4	Embedded Digital Voice Adaptor	10
6	E-DVA POWER REQUIREMENTS	11
6.1	Power Considerations.....	11
6.2	Typical E-DVA Traffic Model.....	11
6.3	Service Requirements Under AC Fail Conditions.....	11
6.4	Local Powering with Battery Backup.....	12
7	E-DVA ANALOG PORT REQUIREMENTS	13
7.1	Loop Start Signaling.....	13
7.1.1	<i>DC Supervisory Range</i>	13
7.1.2	<i>Idle State Voltage</i>	13
7.1.3	<i>Loop Closure Detection</i>	14
7.1.4	<i>Loop Open Detection</i>	14
7.1.5	<i>Off-Hook Delay</i>	14
7.1.6	<i>Flash Hook Delay</i>	14
7.1.7	<i>On-Hook Delay</i>	14
7.1.8	<i>Ringsplash</i>	15
7.1.9	<i>Distinctive Alerting</i>	15
7.1.10	<i>Transmission Path</i>	15
7.2	General Supervision	15
7.2.1	<i>Off-Hook Loop Current</i>	15
7.2.2	<i>Immunity to Line Crosses</i>	15
7.2.3	<i>System Generated Open Intervals</i>	15
7.2.4	<i>Open Switching Interval Distortion</i>	16
7.2.5	<i>Answer Supervision Signal (AnsSup)</i>	16
7.2.6	<i>Dial Pulsing</i>	16
7.2.7	<i>DTMF Signaling</i>	17
7.2.8	<i>Dialtone Removal</i>	17
7.3	General Ringing	17
7.3.1	<i>Alerting Signals</i>	17
7.3.2	<i>Ringling Delay</i>	18
7.3.3	<i>Ringling Source</i>	18
7.3.4	<i>Ringling Capability</i>	18

7.3.5	<i>Ringling Capacity</i>	18
7.3.6	<i>Ring Trip</i>	18
7.3.7	<i>Ring Trip Detect Delay</i>	18
7.3.8	<i>Ring Trip Immunity</i>	18
7.4	Voice Grade Analog Transmission.....	19
7.4.1	<i>Input Impedance</i>	19
7.4.2	<i>Hybrid Balance</i>	19
7.4.3	<i>Longitudinal Balance</i>	19
7.4.4	<i>E-DVA Loss</i>	20
7.4.5	<i>E-DVA Loss Tolerance</i>	20
7.4.6	<i>Frequency Response</i>	20
7.4.7	<i>60 Hz Loss</i>	21
7.4.8	<i>Amplitude Tracking</i>	21
7.4.9	<i>Overload Compression</i>	21
7.4.10	<i>Idle Channel Noise</i>	21
7.4.11	<i>Signal to Distortion</i>	21
7.4.12	<i>Impulse Noise</i>	22
7.4.13	<i>Intermodulation Distortion</i>	22
7.4.14	<i>Single Frequency Distortion</i>	22
7.4.15	<i>Generated Tones</i>	22
7.4.16	<i>Peak-to-Average Ratio</i>	22
7.4.17	<i>Channel Crosstalk</i>	22
7.5	Out of Service Requirements.....	23
7.5.1	<i>E-DVA On Hook State</i>	23
7.5.2	<i>E-DVA Off Hook State</i>	24
7.5.3	<i>DTMF Signaling</i>	25
7.5.4	<i>Expanded Network Service Outages</i>	25
7.6	Message Waiting Indicator.....	25
8	CLIENT REQUIREMENT	27
8.1	Security.....	27
8.1.1	<i>Authentication</i>	27
8.1.2	<i>Signaling Security</i>	27
8.2	NAT/Firewall Traversal.....	27
8.3	Codecs.....	28
8.4	Time keeping.....	29
8.5	Loopback Test Capability.....	29
8.5.1	<i>Test Call Request Encoding</i>	29
8.5.2	<i>E-DVA Requirements on Reception of a Loopback Request</i>	29
9	E-DVA MONITORING REQUIREMENTS	31
9.1	eCM Monitoring.....	31
9.2	E-DVA Monitoring.....	31
9.3	Battery-Backup Monitoring.....	31
9.3.1	<i>Telemetry Signal 1 – AC Fail</i>	32
9.3.2	<i>Telemetry Signal 2 – Replace Battery</i>	32
9.3.3	<i>Telemetry Signal 3 – Battery Missing</i>	32
9.3.4	<i>Telemetry Signal 4 – Battery Low</i>	32
	APPENDIX I ACKNOWLEDGEMENTS	33

Figures

Figure 1 - Telephony Services Over the Data-Over-Cable System.....	7
Figure 2 - PacketCable Functional Components for Residential SIP Telephony.....	8
Figure 3 - E-DVA Protocols.....	10

Tables

Table 1 - E-DVA Traffic Model.....	11
Table 2 - E-DVA Network Disconnect Signaling Event.....	16
Table 3 - E-DVA Answer Supervision Event	16
Table 4 - DTMF Relay Offer	17
Table 5 - E-DVA Provisioned Loss Plan	20
Table 6 - Network/E-DVA On Hook In/Out of Service.....	24
Table 7 - MWI Signal Types	26
Table 8 - E-DVA CODEC Provisioning	28
Table 9 - E-DVA Time Synchronization.....	29

This page left blank intentionally.

1 SCOPE

1.1 Introduction and Purpose

This specification defines the embedded Digital Voice Adaptor (E-DVA) requirements for the analog interface and for powering of the E-DVA. An embedded DVA is a DOCSIS cable modem (CM) integrated with a PacketCable DVA.

The purpose of this specification is to define a set of requirements that will enable a sufficiently reliable service to meet assumed consumer expectations related to residential telephony. These assumed expectations include constant availability, including availability during power failure at the customer's premise, and access to emergency services (911, etc.).

1.2 Requirements

Throughout this document, the words that are used to define the significance of particular requirements are capitalized. These words are:

"MUST"	This word means that the item is an absolute requirement of this specification.
"MUST NOT"	This phrase means that the item is an absolute prohibition of this specification.
"SHOULD"	This word means that there may exist valid reasons in particular circumstances to ignore this item, but the full implications should be understood and the case carefully weighed before choosing a different course.
"SHOULD NOT"	This phrase means that there may exist valid reasons in particular circumstances when the listed behavior is acceptable or even useful, but the full implications should be understood and the case carefully weighed before implementing any behavior described with this label.
"MAY"	This word means that this item is truly optional. One vendor may choose to include the item because a particular marketplace requires it or because it enhances the product, for example; another vendor may omit the same item.

2 REFERENCES

2.1 Normative References

In order to claim compliance with this specification, it is necessary to conform to the following standards and other works as indicated, in addition to the other requirements of this specification. Notwithstanding, intellectual property rights may be required to use or implement such normative references.

- [ANSI T1.401] ANSI T1.401, Network to Customer Installation Interfaces - Analog Voice grade Switched Access Lines Using Loop-Start and Ground Start Signaling, 2000.
- [CODEC-MEDIA] PacketCable Codec-Media Specification, PKT-SP-CODEC-MEDIA-I01-060406, April 6, 2006, Cable Television Laboratories, Inc.
- [DOCSIS OSSIV2.0] DOCSIS Operations Support System Interface Specification, CM-SP-OSSIV2.0-I09-050812, August 12, 2005, Cable Television Laboratories, Inc.
- [DOCSIS RFIv2.0] DOCSIS Radio Frequency Interface Specification, DOCSIS CM-SP-RFIv2.0-I11-060602, June 2, 2006, Cable Television Laboratories, Inc.
- [eDOCSIS] eDOCSIS Specification, CM-SP-eDOCSIS-I09-060728, July 28, 2006, Cable Television Laboratories, Inc.
- [EN 300 659-1] ETSI EN 300 659-1, Access and Terminals (AT); Analogue access to the Public Switched Telephone Network (PSTN); Subscriber line protocol over the local loop for display (and related) services; Part 1: On-hook data transmission, January 2001.
- [EN 300 659-3] ETSI EN 300 659-3, Access and Terminals (AT); Analogue access to the Public Switched Telephone Network (PSTN); Subscriber line protocol over the local loop for display (and related) services; Part 3: Data link message and parameter codings, January 2001.
- [G 168] ITU-T Rec. G.168 (08/04), Digital network echo cancellers.
- [G 711] ITU-T Rec. G.711 (11/88), Pulse code modulation (PCM) of voice frequencies.
- [GR 30] Telcordia GR-30-CORE, LSSGR: Voiceband Data Transmission Interface, December 1998, FR-64.
- [GR 57] Telcordia, GR-57-CORE, Issue 1, October 2001, Functional Criteria for Digital Loop Carrier (DLC) Systems.
- [GR 303] Telcordia GR-202, Issue 4, Integrated Digital Loop Carrier System Generic Requirements, Objectives, and Interface, December 2002,
- [GR 499] Telcordia GR-499-CORE, Issue 4, Transport Systems Generic Requirements (TSGR): Common Requirements, September 2004.
- [GR 506] Telcordia GR-506-CORE, LSSGR: Signaling for Analog Interfaces, November, 1996, FR-64.
- [GR 909] Telcordia, GR-909-CORE, Issue 2, Generic Requirements and Objectives for Fiber in the Loop (FITL) Systems, December 2004.
- [GR 1089] Telcordia GR-1089-CORE, Issue 4, Generic Requirements for Electronic Equipment Cabinets, Electromagnetic Compatibility and Electrical Safety Generic Criteria for Network Telecommunications Equipment, June 2006.
- [GR 1401] Telcordia GR 1401, LSSGR: Visual Message Waiting Indicator Generic Requirements (FSD 01-02-2000), June 2000, FR-64.

[ID MMUSIC LOOPBACK]	IETF Internet Draft, An Extension to the Session Description Protocol (SDP) for Media Loopback, draft-ietf-mmusic-media-loopback-04.txt, August 2006, work in progress.
[ID SIP ANSWERMODE]	IETF Internet Draft, Requesting Answering Modes for the Session Initiation Protocol (SIP), draft-ietf-sip-answer-mode-01, April 2006, work in progress.
[PKT 23.228]	PacketCable IP Multimedia Subsystem Stage 2 Specification 3GPP TS 23.228, PKT-SP-23.228-I01-060406, April 6, 2006, Cable Television Laboratories, Inc.
[PKT 24.229]	PacketCable SIP and SDP Stage 3 Specification 3GPP TS 24.229, PKT-SP-24.229-I01-060406, April 6, 2006, Cable Television Laboratories, Inc.
[PKT 33.203]	PacketCable Access Security for IP-Based Services Specification 3GPP TS 33.203, PKT-SP-33.203-I01-060406, April 6, 2006, Cable Television Laboratories, Inc.
[RFC 4330]	IETF RFC 4330, Simple Network Time Protocol version 4 for IPv6, IPv4, and OSI, January, 2006.
[RST PACM]	PacketCable Residential SIP Telephony PACM Specification, PKT-SP-RST-PACM-I01-060927, September 27, 2006, Cable Television Laboratories, Inc.
[RSTF]	PacketCable Residential SIP Telephony Feature Specification, PKT-SP-RSTF-I01-060927, September 27, 2006, Cable Television Laboratories, Inc.
[SEC1.5]	PacketCable 1.5 Security Specification, PKT-SP-SEC1.5-I01-050128, January 28, 2005, Cable Television Laboratories, Inc.
[SR-TSV-002476]	Telcordia Special Report, SR-TSV-002476, CPE Compatibility Considerations for the Voiceband Data Transmission Interface, December 1992.

2.2 Informative References

This specification uses the following informative references.

[ANSI T1.508]	ANSI T1.508, Network Performance - Loss Plan for Evolving Digital Networks, 1998.
[ARCH-FRM TR]	PacketCable Architecture Framework Technical Report, PKT-TR-ARCH-FRM-V01-060406, April 4, 2006, Cable Television Laboratories, Inc.
[GR 517]	Telcordia (Bellcore) GR-517-CORE, Issue 1, LEC Traffic Environment Characteristics, December 1998.
[Key Smith]	P. Key and D. Smith (editors). 1999. <i>The Internet & The Public Switched Telephone Network – A Troubled Marriage</i> . In <i>Teletraffic Engineering in a Competitive World</i> . Edinberg: Elsevier.
[NFT TR]	PacketCable NAT and Firewall Traversal Technical Report, PKT-TR-NFT-V01-060406, April 6, 2006, Cable Television Laboratories, Inc.
[TIA-912a]	TIA-912a Telecommunication - IP Telephony Equipment - Voice Gateway Transmission Requirements, August 2004.
[TSB-122a]	TIA/EIA/TSB 122a, Telecommunications - IP Telephony Equipment - Voice Router/Gateway Loss and Level Plan Guidelines, March 2001.
[V.25]	ITU-T Rec. V.25 (10/96), Automatic answering equipment and general procedures for automatic calling equipment on the general switched telephone network including procedures for disabling of echo control devices for both manually and automatically established calls.

2.3 Reference Acquisition

- Cable Television Laboratories, Inc., 858 Coal Creek Circle, Louisville, CO 80027; Phone 303-661-9100; Fax 303-661-9199; Internet: <http://www.cablelabs.com/>
- IHS Standards Store, Internet: <http://global.ihs.com/>
- Internet Engineering Task Force (IETF), Internet: <http://www.ietf.org/>
Note: Internet-Drafts are draft documents valid for a maximum of six months and may be updated, replaced, or obsoleted by other documents at any time.
The list of current Internet-Drafts can be accessed at <http://www.ietf.org/ietf/1id-abstracts.txt>.
- ITU-T Recommendations: www.itu.int/ITU-T/publications/recs.html
- Telcordia Technologies, Internet: <http://www.telcordia.com/>

3 TERMS AND DEFINITIONS

This specification uses the following terms:

Customer Premise Equipment	Usage of CPE within this specification generically refers to the cable modem and E-DVA device that resides at the subscriber home, as well as any customer telephony equipment (telephones, answering machines, fax machines, etc.). Typically, CPE would refer to equipment that is beyond the service provider network interface, such as a telephone or personal computer. However, since the cable modem and E-DVA represent the service provider network interface device at the subscriber home, it is commonly referred to as CPE.
Hybrid Fiber Coax	Access network architecture consisting of fiber optic feeders from the head end to nodes, at which point coaxial cable is used for the final distribution to the subscribers.
Telcordia (Bellcore)	PSTN research/standards organization.
Uninterruptible Power Supply	A power supply including a battery for backup power when AC input power fails.

4 ABBREVIATIONS AND ACRONYMS

This specification uses the following abbreviations:

A/D	Analog to Digital converter
CCS	One Hundred Call Seconds
CM	Cable Modem
CMS	Call Management Server
CMTS	Cable Modem Termination System
CPE	Customer Premise Equipment
CSCF	Call State Control Function
D/A	Digital to Analog converter
DOCSIS®	Data-Over-Cable System Interface Specifications
DTMF	Dual Tone Multi Frequency
DVA	Digital Voice Adaptor
eCM	Embedded Cable Modem
eDOCSIS™	Embedded Data-Over-Cable System Interface Specification
E-DVA	Embedded Digital Voice Adaptor
FITL	Fiber In The Loop. A PSTN architecture consisting of a fiber optic access network.
HFC	Hybrid Fiber Coax
IP	Internet Protocol. A network layer protocol
LEC	Local Exchange Carrier
NAT	Network Address Translation
NCS	Network Call Signaling
OSSI	Operations Support System Interface
PACM	Provisioning, Activation, Configuration, and Management
POTS	Plain Old Telephone Service
PSTN	Public Switched Telephone Network
RST	Residential SIP Telephony
RTCP	Real Time Control Protocol
RTCPXR	Real Time Control Protocol Extended Reports
SDP	Session Description Protocol
SIP	Session Initiation Protocol
STUN	Simple Traversal of User Datagram Protocol (UDP) Through Network Address Translators
UDP	User Datagram Protocol
UPS	Uninterruptible Power Supply

5 OVERVIEW

5.1 PacketCable Overview

PacketCable is a project conducted by Cable Television Laboratories, Inc. (CableLabs®) and its member companies. The PacketCable project is aimed at defining interface specifications that can be used to develop interoperable equipment capable of providing packet-based voice, video, and other high-speed multimedia services over hybrid fiber coax (HFC) cable systems utilizing the Data-Over-Cable Interface Specification [DOCSIS RFIv2.0].

5.2 Service Goals

One application of the PacketCable architecture is packet-based voice communications for cable system subscribers. The PacketCable architecture as a whole enables voice communications, video, and data services based on bi-directional transfer of Internet Protocol (IP) traffic between the cable system headend and customer locations, over an all-coaxial or HFC cable network as shown in simplified form in Figure 1.

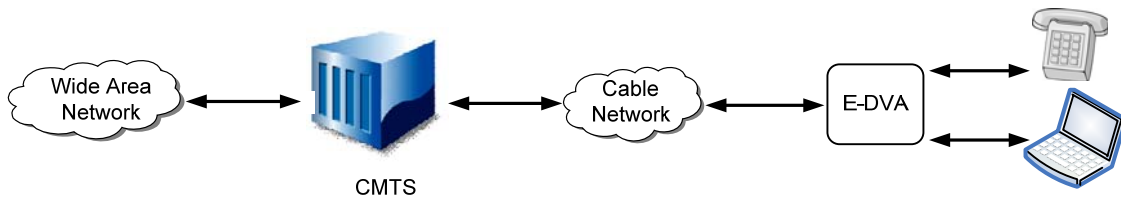

Figure 1 - Telephony Services Over the Data-Over-Cable System

The transmission path over the cable system is realized by a cable modem termination system (CMTS) and at each customer location by a cable modem (CM). The E-DVA includes an embedded cable modem and a Residential SIP Telephony (RST) client and analog ports for telephone devices. The E-DVA may include digital ports. The conversion between digital RST signaling and voice to analog telephone interfaces is accomplished within the E-DVA.

5.3 PacketCable Reference Architecture

The PacketCable architecture for Residential SIP Telephony is based on the IMS Release 6 architecture, so many different element names will use the same name as the IMS architecture. This architecture is more fully described in the PacketCable Architecture Framework Technical Report [ARCH-FRM TR]. Figure 2 defines the functional components of the architecture.

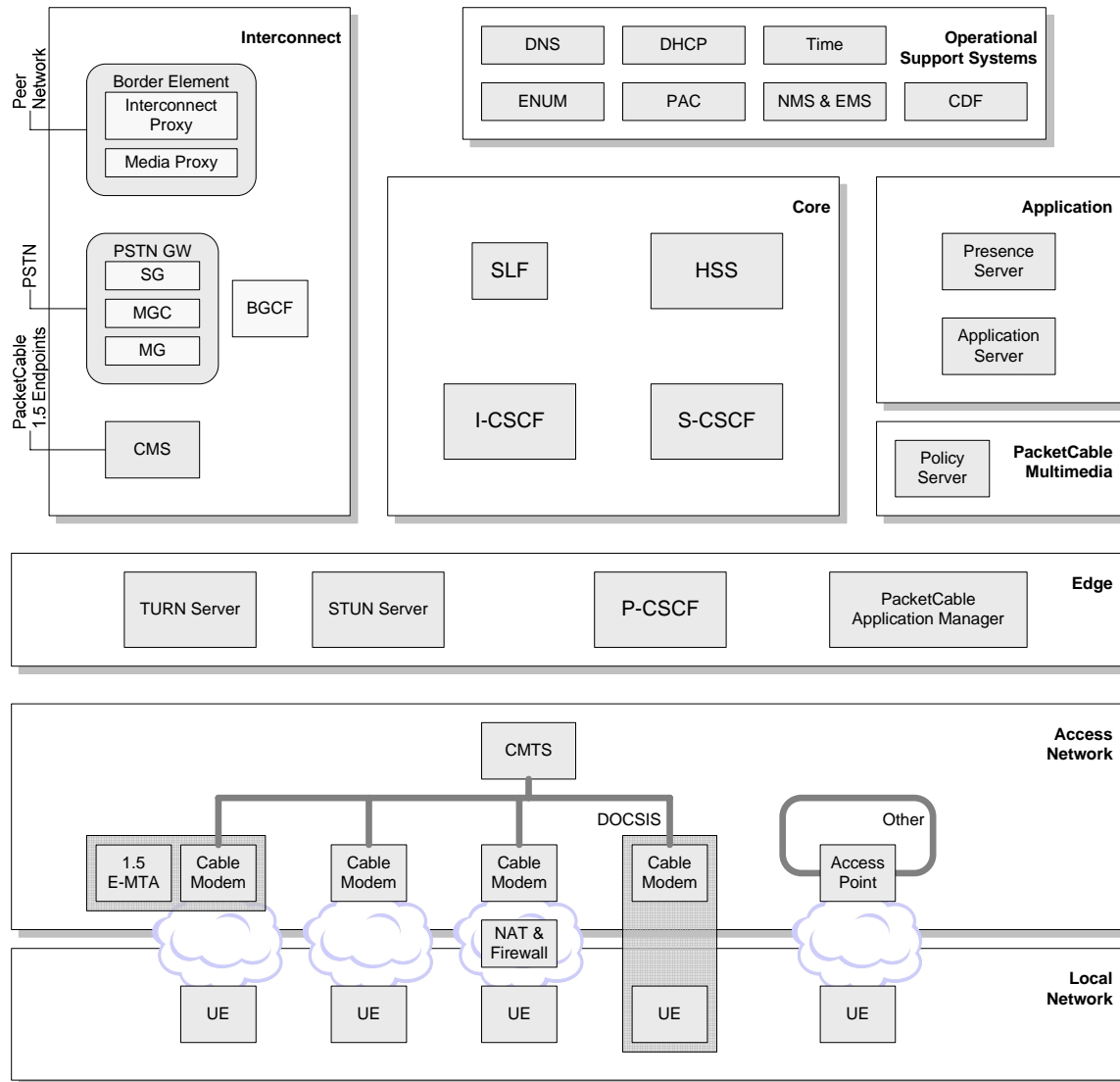

Figure 2 - PacketCable Functional Components for Residential SIP Telephony

Embedded Digital Voice Adapter (E-DVA): The Embedded Digital Voice Adapter is a Multimedia Terminal Adapter that has been integrated with a Cable Modem as a single unit. The E-DVA hosts PacketCable SIP Client software, and provides an analog telephone connection (or integrated analog telephone unit) with residential telephone capabilities.

Access Network: The PacketCable Access Network connects the Cable Modem of the E-DVA with the Cable Modem Termination System (CMTS). Together, these elements provide an internet protocol (IP) connection between the local network and the PacketCable Edge Network.

Edge Network: The PacketCable Edge Network contains the following elements:

- Proxy - Call Session Control Function (P-CSCF): The P-CSCF is a SIP proxy that is the first point of contact for the SIP client.
- STUN Server: The Symmetrical Traversal of UDP through NATs (STUN) Server provides for traversal of telephony-related packet traffic through Network Address Translation (NAT) firewalls, if present.

- **TURN Server:** The Traversal Using Relay NAT (TURN) Server provides additional capabilities for traversal of NAT firewalls.
- **Quality of Service State Agent and Quality of Service Application Manager:** The QoS State Agent and QoS Application Manager act on behalf of E-DVAs to reserve QoS resources in the network so that the network will provide reserved bandwidth for telephone calls.

SIP Network Elements: The PacketCable SIP Network contains the following elements:

- **Serving - Call Session Control Function (S-CSCF):** The S-CSCF is a SIP Server that provides session control for subscribers accessing services within the PacketCable core network.
- **Home Subscriber Server (HSS):** The HSS is a database that provides subscriber-related information and can provide authorization and authentication information.
- **Interrogating - Call Session Control Function (I-CSCF):** The I-CSCF is a SIP proxy located at the logical edge of the PacketCable Network. Remote servers (e.g., a P-CSCF in a visited domain or an S-CSCF in a foreign domain) can use it as an entry point for all SIP signaling interactions with the PacketCable domain. The I-CSCF queries the HSS to retrieve the user location, and then routes the SIP request to its assigned S-CSCF. It can also be used to hide the topology of the PacketCable Network from those outside the PacketCable domain.

Application Components: The PacketCable Application Components are:

- **Application Server(s):** The application server(s) are SIP servers that provide service execution resources for specific services operating on the PacketCable network, including some Residential SIP Telephony applications.
- **Presence Server(s):** The presence server(s) allow functional components to publish state information and allow other functional components to subscribe to this information. Presence servers notify subscribers when state information changes.

Operational Support Components: The PacketCable Operational Support Components are:

- **Master Subscriber Information System:** A database of subscriber information.
- **Network Management System (NMS) and Element Management System (EMS):** Systems for monitoring and managing the network and the elements contained in the network.
- **Provisioning, Activation, and Configuration (PAC) Server:** Manages the delivery and synchronization of key provisioning and configuration data to functional components, including the E-DVAs.
- **Dynamic Host Configuration Protocol (DHCP) Server:** Manages delivery of key network element data such as IP addresses.
- **Domain Name Server (DNS) and ENUM Servers:** DNS provides domain name translation to IP addresses, and the ENUM Server translates E.164 telephone numbers to Uniform Resource Identifiers (URIs) and vice versa.

PacketCable Multimedia Policy Server: Governs the allocation of QoS resources in the PacketCable network.

Interconnect Components: The PacketCable Network Interconnect Components are:

- **Border Element:** Controls and enables managed SIP-based interactions with other SIP networks.
- **Public Switched Telephone Network Gateway (PSTN GW):** Controls and enables managed inter-working between the PacketCable Network and traditional telephone networks.

- Call Management Server (CMS): Controls a PacketCable telephony network with NCS-based clients. The PacketCable CMS communicates with the CSCFs as a peer.

5.4 Embedded Digital Voice Adaptor

A Digital Voice Adaptor (DVA) is a PacketCable client device that contains a subscriber-side interface to the subscriber's CPE (e.g., telephone) and a network-side signaling interface to call control elements in the network (e.g., P-CSCF, S-CSCF, Application servers, etc). A DVA provides codecs and all signaling and encapsulation functions required for media transport and call signaling.

DVAs reside at the customer site and are connected to other PacketCable network elements via the HFC access network (DOCSIS). PacketCable DVAs are required to support the SIP protocol as specified in PacketCable specification [RSTF].

PacketCable only defines support for an embedded DVA (E-DVA). An E-DVA is a single hardware device that incorporates a DOCSIS 1.1 or higher CM as well as a PacketCable DVA component. Figure 3 shows a representative functional diagram of an E-DVA. Additional E- DVA functionality is further defined in [ARCH-FRM TR]. For the purposes of this specification, DVA is interpreted to be identical to E-DVA.

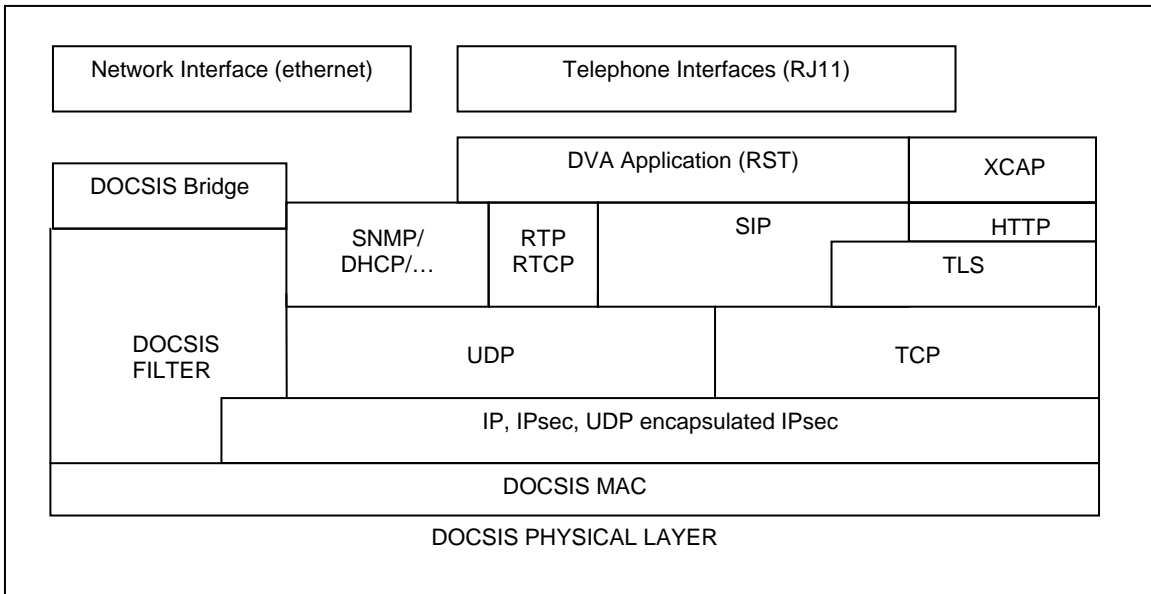

Figure 3 - E-DVA Protocols

6 E-DVA POWER REQUIREMENTS

This section defines the power requirements of the E-DVA. This includes power consumption and presents associated traffic models recommended for power consumption calculations.

6.1 Power Considerations

Local power refers to utilizing the subscriber's home AC utility power as the supply for the E-DVA. A battery backup is utilized to provide telephony services when the utility power fails.

6.2 Typical E-DVA Traffic Model

A projected "typical" E-DVA traffic model has been developed based on [GR 517] and [Key Smith] and input from cable operators. With this qualification, this model may be used to calculate long term average power.

Table 1 - E-DVA Traffic Model

Line Number	E-DVA Line 1	E-DVA Line 2	E-DVA Line 3	E-DVA Line 4	Cable Modem Data
Assumed Use	Voice	Modem/ Voice	Voice/Fax	Voice	High Speed Data
CCS (100 call seconds)	4	4	2	2	4
Line Penetration (Normalized by Penetration)	100%	80%	50%	25%	25%
Average Ringing Period	14 sec	14 sec	14 sec	14 sec	n/a
Average call length					
E-DVA w/o Data Service	5 min	26 min	5 min	5 min	n/a
E-DVA with Data Service	5 min	5 min	5 min	5 min	n/a
Average Data Rate to Subscriber	n/a	n/a	n/a	n/a	100kb/s
Average Data Rate From Subscriber	n/a	n/a	n/a	n/a	10kb/s

The average cable modem data rates shown in Table 1 assume that when a user is active on the system (i.e., 4CCS), the user is interpreting or typing information during 90% of the active session, and no significant data is flowing through the data interface. Data interface rates of 1Mb/s to the subscriber and 100kb/s from the subscriber are assumed during the remaining 10% of the session. The averages are assumed to be long term and are considered over the entire domain of a power node (i.e., 100's of E-DVAs).

6.3 Service Requirements Under AC Fail Conditions

The E-DVA MUST remain operational during the switch between AC outage to battery backup. The E-DVA MUST also maintain provisioned services (operational means capable of originating calls, ringing, and terminating calls, if provisioned as in-service). When in battery mode, services will be offered as configured by the operator. This configuration may be different from the services when provided with AC power. The E-DVA MUST maintain established telephony calls across the switch over between AC power

and battery back up. Since data traffic is not required for PacketCable service, the E-DVA data service MAY be de-activated immediately under local AC power fail conditions.

6.4 Local Powering with Battery Backup

Local powering is accomplished utilizing a UPS that converts household 120V AC power to DC power for the E-DVA. The UPS also provides battery backup to bridge E-DVA operation through typical local power outages. In addition, telemetry signals provide remote monitoring capability for local AC power and battery conditions. The indoor climate controlled environment is typically desired for battery placement to maximize battery life. E-DVAs MAY include an embedded UPS or utilize an external UPS.

7 E-DVA ANALOG PORT REQUIREMENTS

The E-DVA analog port represents an interface between the PacketCable/DOCSIS/IP (Internet protocol) network and devices designed to function when connected to the PSTN using standard PSTN interfaces. The subscriber side of this interface is an analog interface consistent with the PSTN, and the network side of this interface is a digital interface to the IP-based PacketCable network, which rides on top of the DOCSIS transport. It is expected that many operators will choose to use the PacketCable architecture to offer service to customers in residential dwellings. In such applications, the E-DVA will reside at the subscriber premises, typically as an interior unit with battery backup. Finally, because the network side of the port interface is digital, and the device resides close to the subscriber, the analog subscriber side of the port interface will only be required to support relatively short metallic (copper twisted pair) drops (i.e., 500 feet).

This interface is similar to the Telcordia GR-909 POTS interface requirements for FITL (fiber in the loop). Therefore, the port requirements are based on GR-909-CORE [GR 909]. For basic PacketCable service, the requirements can be divided into four categories:

- Loop Start Signaling (section 4.1 of [GR 909])
- General Supervision (section 4.4 of [GR 909])
- General Ringing (section 4.5 of [GR 909])
- Voice Grade Analog Transmission (section 5 of [GR 909])

The E-DVA analog 2-wire interface requirements are listed in the following sections.

For the purpose of this section, the subscriber twisted pair copper wiring (typically the wiring inside the subscriber's premises) that is connected to the E-DVA analog port will be referred to as the "loop." Note that this usage is different than the way these terms may be used in the context of the PSTN, in which the "loop" is defined as the transmission path between a telephone company central office and a customer's premises. The "loop" referred to in this section, in PSTN terms, would typically be referred to as "premises wire" or "inside wire." References here to "loops" and "transmission paths" should not be confused with links from customer premises to either a telephone company office or to a cable operator's headend.

7.1 Loop Start Signaling

7.1.1 DC Supervisory Range

The DC supervisory range **MUST** meet: $R_{DC} \geq 450$ ohms. R_{DC} is the DC supervisory range. The actual value of R_{DC} depends on the resistance of the loop wire from the E-DVA (the subscriber's inside wiring). That is, $R_{DC} = 430 \text{ Ohms} + R_{loop}$. Note that this accommodates a drop of 500 feet of AWG 22-gauge wire at 65 degrees Celsius.

Reference: section 4.1.1 of [GR 909].

7.1.2 Idle State Voltage

The idle state is when the loop is open or on-hook. In this state, the idle voltage **MUST**:

- be $42.75 \text{ Vdc} \leq V_{IDLE} \leq 80 \text{ V DC}$; and
- have Class A2 continuous source electrical safety from section 14.6 of [GR 499] satisfied.

In this state, the idle voltage SHOULD:

- have a Ring that is negative with respect to tip
- have Ring-to-ground and tip-to-ground voltages that are < 0

Reference: section 4.1.2 of [GR 909].

7.1.3 Loop Closure Detection

Loop closure is off-hook. Detection of loop closure in the E-DVA MUST meet:

- Resistance $\leq R_{DC}$ between tip and ring is loop closure
- Resistance $\geq 10k$ ohms between tip and ring is not loop closure

Reference: section 4.1.4 of [GR 909].

7.1.4 Loop Open Detection

Loop open is on-hook. Detection of loop open in the E-DVA MUST meet:

- Resistance $\geq 10k$ ohms is loop open
- Resistance $\leq R_{DC} + 380$ ohms is not loop open

The E-DVA MUST be able to distinguish between a hit, dial pulse, flash, or disconnect.

Reference: section 4.1.5 of [GR 909].

7.1.5 Off-Hook Delay

The E-DVA MUST meet the timing requirements R11-33 of [GR 506] for detecting a subscriber origination request (off-hook).

The E-DVA MUST be able to generate the local dial tone within 50 msec of detecting a subscriber origination request (off-hook).

The E-DVA MUST be capable of establishing a 2-way voice signal transmission capability on the loop established within 50 msec of detecting the subscriber termination request (off-hook).

Reference: section 4.1.7 of [GR 909].

7.1.6 Flash Hook Delay

The E-DVA MUST meet the timing requirements in section 12 of [GR 506] for detecting a flash signal and a subscriber termination request (on-hook).

The E-DVA MUST be able to signal to the network about a flash signal within 50 msec of detecting such an event.

7.1.7 On-Hook Delay

The E-DVA MUST meet the timing requirement in section 12 of [GR 506] for detecting an on-hook signal and a subscriber termination request (on-hook).

The E-DVA MUST be able to signal to the network about an on-hook signal or a subscriber termination request within 50 msec of detecting such an event.

7.1.8 Ringsplash

When a feature requires one 500 msec ringsplash, the E-DVA MUST apply one 500 +/- 50 msec ring burst to the line.

Reference: section 4.1.9 of [GR 909].

7.1.9 Distinctive Alerting

Defined ring cadences MUST be applied to the drop within +/-50 msec resolution. The E-DVA MUST be able to apply any of the distinctive alerting patterns described in the PacketCable Residential SIP Telephony Feature Specification [RSTF] on the line when signaled by the PacketCable network.

Reference: section 4.1.10 of [GR 909].

7.1.10 Transmission Path

The E-DVA MUST support part-time on-hook transmission capabilities: part-time = within 400 msec after a ringsplash. On-hook transmission provides the capability of transmitting a voiceband signal in both directions on the loop when the loop is open (on-hook).

Reference: section 4.1.15 of [GR 909].

7.2 General Supervision

7.2.1 Off-Hook Loop Current

The E-DVA MUST provide at least 20 mA of loop current in the off-hook state. Loop voltage is such that the ring conductor is negative with respect to the tip conductor.

Reference: section 4.2.1 of [GR 909].

7.2.2 Immunity to Line Crosses

Shorts between tip-to-tip, tip-to-ring, or ring-to-ring involving two or more lines MUST NOT damage the E-DVA. Shorts between tip-to-ground or ring-to-ground involving one or more lines MUST NOT damage the E-DVA.

Reference: section 4.4.3 of [GR 909].

7.2.3 System Generated Open Intervals

When in the loop closure state (off-hook), interruptions to loop current feed on the E-DVA MUST NOT exceed 100 msec.

Reference: section 4.4.5 of [GR 909].

Network Disconnect (or Loop Current Feed Open) is signaled by the network side of a loop start interface when the distant end releases while the CPE is offhook. Typically this signal is used to notify electronic equipment, such as answering machines, that the caller has hung up. When provisioned to do so via the

NetDisc data element, the E-DVA MUST remove DC bias for 1 second +/- 400 milliseconds when a call has been cleared by the network.

Table 2 - E-DVA Network Disconnect Signaling Event

Data	Type	Persistence	Scope	Stored by	Written by	Read by	Range	Increments	Default
NetDisc	Integer (mSec)	Non-volatile	Per Line	E-DVA	XDS	XDS, E-DVA	0 to 2000	100	1000

NetDisc value of 0 indicates that the E-DVA MUST NOT remove DC bias when a call disconnects. The default value of NetDisc should be 1000 milliseconds. The default NetDisc for Answer Signal should be "off."

7.2.4 Open Switching Interval Distortion

The following are the Open Switching Interval Distortion requirements. When in the loop closure state and providing loop current feed, E-DVA loop current feed open commands of duration, T MUST have resolution +/-25 msec for $50 \leq T \leq 1000$ msec. When in the above state, the E-DVA MUST continue to maintain loop closure with no interruptions >1 msec.

- Loop current feed open MUST NOT exceed 5 sec in duration.
- Loop current feed is an interruption of the loop current sourced on the drop.

Reference [GR 303] specifies that these closure requirements MUST be satisfied for both on-hook and off-hook.

Reference: section 4.4.6 of [GR 909].

7.2.5 Answer Supervision Signal (AnsSup)

Answer Supervision (also called battery reversal, reverse DC bias, or Reverse Loop Current Feed) is signaled when the distant end answers a call originated by the CPE. Typically this signal is used to notify electronic equipment such as PBXs which have a local billing system that a call has been answered. When provisioned to do so via the AnsSup data element, the E-DVA MAY reverse DC bias when a call has been answered.

Table 3 - E-DVA Answer Supervision Event

Data	Type	Persistence	Scope	Stored by	Written by	Read by	Range	Increments	Default
AnsSup	Boolean	Non-volatile	Per Line	E-DVA	XDS	XDS, E-DVA	Off/On	N/A	Off

The default AnsSup value for Answer Signal should be "off."

7.2.6 Dial Pulsing

Dial pulses MUST be collected at the E-DVA. The digits are gathered according to the digit map and all digits are sent in a single message. The E-DVA MUST support 8-12 pps with a 58-64% break.

Reference: section 4.4.9 of [GR 909].

7.2.7 DTMF Signaling

The E-DVA MUST support the use of DTMF for both dialed digits and for the relay of digits as part of an established session. When dialing the DTMF, signaling MUST be collected at the E-DVA. The digits are gathered according to the digit map and all digits are sent in a single message.

The E-DVA MUST NOT amplitude overload at the maximum expected DTMF signal level per [ANSI T1.401]. ([ANSI T1.401] describes the maximum DTMF signal level.) Amplitude overload is any output frequency between 0 – 12 kHz at a power level greater than -28 dBm0, when the input frequency is between 600 – 1500 Hz at a power level equal to the maximum expected DTMF signal level.

The E-DVA MUST apply DTMFs tone to the audio path, or the E-DVA MUST generate DTMF relay per [CODEC-MEDIA] as dictated from the negotiated SDP associate with the session.

The E-DVA MUST offer DTMF relay within SDP upon session origination as provisioned in the DTMF RELAY feature data element.

Table 4 - DTMF Relay Offer

Data	Type	Persistence	Scope	Stored by	Written by	Read by	Range	Increments	Default
DTMF RELAY	Boolean	Non-volatile	Per E-DVA	XDS	XDS	XDS E-DVA	Off/On	N/A	ON

The default value of DTMF_RELAY = ON instructs the E-DVA to offer DTMF relay within SDP upon session origination.

7.2.8 Dialtone Removal

The E-DVA MUST remove dialtone within 250 msec of detecting the first dialed digit.

Subsequent digit analysis in accordance to the digit map may result in re-application of dialtone by the E-DVA. The requirement for dialtone removal also applies to such a re-application of the dialtone.

Note, however, that the act of re-applying the dialtone is a digit map action and independent of this requirement.

7.3 General Ringing

7.3.1 Alerting Signals

The E-DVA MUST support unbalanced or balanced ringing. The applied cadence MUST be within +/-50 msec of the defined cadence. Nominal cadence has a 6-sec period with 1.7 to 2.1 sec ringing and 3.1 to 5.5 sec of silence.

For Unbalanced Ringing, the alerting cadence is applied to ring with tip grounded. The DC component during ringing is such that the ring conductor is negative with respect to tip.

For Balanced Ringing, the alerting cadence is applied to both tip and ring, typically 180° out of phase, with or without a DC component.

Reference: section 4.5.2 of [GR 909]. Modified for PacketCable for optional balanced ringing.

7.3.2 Ringing Delay

Ringing MUST be applied within 200 msec of the E-DVA receiving SIP INVITE with SDP. The cadence MUST be used as per PACM configuration entered at any point (i.e., the cadence may start with the silent period).

Reference: section 4.5.3 of [GR 909].

7.3.3 Ringing Source

The E-DVA Ringing Source MUST meet the duration-limited source safety requirements of [GR 1089].

The E-DVA ringing frequency MUST be 20+/-1 Hz.

The E-DVA ringing source DC component (offset) MUST be ≤ 75 Vdc.

The E-DVA Ringing Source MUST meet $1.2 \leq$ peak-to-rms voltage ratio ≤ 1.6 .

The E-DVA ringing source bridged C-weighted noise MUST be ≤ 90 dBnC, when referenced to 900 ohms during ringing (i.e., the 20 Hz component < 0 dBm), and the analog voice band lead conducted emissions criteria of [GR 1089].

Reference: section 4.5.4 of [GR 909].

7.3.4 Ringing Capability

The minimum ringing voltage of the E-DVA MUST meet 40 Vrms across a 5 REN load on a drop with resistance $\leq R_{DC} - 400$ ohms.

Reference: section 4.5.5 of [GR 909].

7.3.5 Ringing Capacity

The E-DVA MUST be capable of supporting 5 REN per analog line as described in [GR 909].

Reference: section 4.5 of [GR 909].

7.3.6 Ring Trip

The E-DVA Ringing MUST be removed within 200 msec of detecting loop closure.

Reference: section 4.5.7 of [GR 909].

7.3.7 Ring Trip Detect Delay

The E-DVA MUST be able to detect a ring trip within 300 msec.

Reference: section 4.5.8 of [GR 909].

7.3.8 Ring Trip Immunity

E-DVA Ringing MUST NOT be tripped when a termination of 10k ohm in parallel with 6 uF is applied between tip and ring.

E-DVA Ringing MUST NOT be tripped when a termination of 200 ohm is applied between tip and ring for ≤ 12 msec.

Reference: section 4.5.9 of [GR 909].

7.4 Voice Grade Analog Transmission

The PacketCable system utilizes digital transmission of voice signals to and from the DVA. The DVA converts between the digital voice signal on the IP network and the analog voice signal on the tip and ring loop. System impairments in the digital network, such as packet loss, can affect the voice signal but are outside the control of the DVA. Therefore, this section defines the analog voiceband requirements of the DVA and assumes an error-free digital network.

These requirements are derived from the PSTN, which, in some cases, utilizes analog transmission from a headend central office switch to a customer. Typically, the reference point by which these requirements are measured is the middle of the switch (digital to analog). This reference point is referred to as the 0 Transmission Level Point (TLP) and could be thought of as any point in the digital portion of the network.

Note that these are not end-to-end analog requirements since they apply to a single digital to analog conversion point (a typical voice call will be analog at each end with a digital network connecting the two ends). The 0 TLP of the PacketCable system is any point in the digital IP network. The digital IP network, for voice signal transmission purposes, extends all the way to the DVA where the digital to analog conversion occurs. These requirements only apply to the G.711 audio codec as specified in [CODEC-MEDIA]. Transmission requirements for the other compression algorithms specified in [CODEC-MEDIA] are not yet defined.

In general, all these requirements **MUST** be satisfied for both on-hook and off-hook parameters.

7.4.1 Input Impedance

The E-DVA input impedance **MUST** meet:

- 600 ohms nominal
- ERL (echo return loss) > 26 dB (29 dB objective)
- SRL (singing return loss) > 21 dB (24 dB objective)

Reference: section 5.3.3 of [GR 909].

7.4.2 Hybrid Balance

The E-DVA Hybrid Balance **MUST** meet, where L_{T1} is transmit loss and L_{R1} is receive loss at 1004 Hz:

- $ERL > 21$ dB (26 dB objective)
- $SRL > 16$ dB (21 dB objective)
- $ERL = 15 + L_{T1} + L_{R1}$
- $SRL = 10 + L_{T1} + L_{R1}$

Reference: section 5.3.4 of [GR 909].

7.4.3 Longitudinal Balance

The E-DVA Longitudinal Balance **MUST** meet:

- 200 Hz: min > 45 dB, ave > 50 dB (ave > 61 dB objective)
- 500 Hz: min > 45 dB, ave > 50 dB (ave > 58 dB objective)

- 1000 Hz: min > 45 dB, ave > 50 dB (ave > 52 dB objective)
- 3000 Hz: min > 40 dB, ave > 45 dB

Reference: section 5.3.5 of [GR 909].

7.4.4 E-DVA Loss

The E-DVA loss plan is part of a network loss plan, which considers not only the analog loss between end points, but also the end to end delay, the loop back delay, noise and echo cancellation. Guidance in setting the DVA loss can be found in [ANSI T1.508], [TSB-122a], and [TIA-912a] Table 1, which defines various termination points across a network.

Additional consideration must be taken due to the short analog loop architecture with the DVA. In this configuration there is a potential risk of G.711 codec overload with DTMF signaling. In this configuration it is recommended that an additional loss in each direction (D/A and A/D) be configured in the DVA.

Additionally, variations in network deployments result in variations in the end to end and loop back delays. These delay variations must also be considered in setting the loss plan values.

Due to these considerations, for each telephony line, the DVA MUST support two provisioned loss parameters, one for the D/A direction (towards the subscriber) and one for A/D direction (from the subscriber) direction.

The E-DVA MUST support a provisioning range of 0 dB to 12 dB of loss in 1 dB increments.

Table 5 - E-DVA Provisioned Loss Plan

Data	Type	Persistence	Scope	Stored by	Written by	Read by	Range	Increments	Default
D/A Loss	Integer (dB)	Non-volatile	Per Line	E-DVA	XDS	XDS, E-DVA	0 to 12	1	6
A/D Loss	Integer (dB)	Non-volatile	Per Line	E-DVA	XDS	XDS, E-DVA	0 to 12	1	6

Note: In loss planning, positive numbers represent loss and negative numbers represent gain.

7.4.5 E-DVA Loss Tolerance

E-DVA Loss Tolerance MUST be within +/-0.5 dB of the provisioned loss.

Reference: [TIA-912a] clause 6.5.4.1.

7.4.6 Frequency Response

The E-DVA Off-hook transmission loss between 400-2800 Hz MUST be within -0.5 to +1 dB of the loss at 1004 Hz using a 0 dBm0 signal.

The E-DVA On-hook transmission loss between 400-2800 Hz MUST be within -1 to +2 dB of the loss at 1004 Hz using a 0 dBm0 signal. (+ means more loss, - means less loss).

Reference: section 6.1.9 of [GR 57].

7.4.7 60 Hz Loss

The E-DVA transmission path loss at 60 Hz MUST be at least 20 dB greater than the off-hook transmission path loss at 1004 Hz. The intention is to limit the encoding of 60 Hz induction in the A/D direction.

Reference: section 6.1.10 of [GR 57].

7.4.8 Amplitude Tracking

The E-DVA deviation of a 1004 Hz off-hook transmission path loss relative to the loss of a 0 dBm0 input signal MUST meet:

- -37 to +3-dBm0 input: +/-0.5 dB max (+/-0.25 dB ave)
- -50 to -37-dBm0 input: +/-1.0 dB max (+/-0.5 dB ave)
- -55 to -50-dBm0 input: +/-3.0 dB max (+/-1.5 dB ave)

The E-DVA deviation of a 1004 Hz on-hook transmission path loss relative to the loss of a 0 dBm0 input signal MUST meet:

- -37 to 0 dBm0: +/-0.5 dB max

Reference: section 6.1.11 of [GR 57].

7.4.9 Overload Compression

The increase in the E-DVA off-hook transmission path loss at 1004 Hz relative to the loss of a 0 dBm0 input signal MUST meeting the following:

- +3 dBm0 input: <= 0.5 dB increased loss
- +6 dBm0 input: <= 1.8 dB increased loss
- +9 dBm0 input: <= 4.5 dB increased loss

This is to ensure the receiver off-hook signal can be transmitted.

Reference: section 6.1.12 of [GR 57].

7.4.10 Idle Channel Noise

The idle channel noise MUST NOT exceed 20 dBmC at the output of the E-DVA (18 dBmC objective).

Reference: section 6.1.13 of [GR 57].

7.4.11 Signal to Distortion

The E-DVA ratio of the output signal to output C-notched noise with a 1004 Hz input signal while providing an onhook and off-hook transmission path MUST meet:

- 0 to -30-dBm0 input: >33-dB ratio
- -30 to -40-dBm0 input: >27-dB ratio
- -40 to -45-dBm0 input: >22-dB ratio

Reference: section 5.3.15 of [GR 909] and section 6.1.14 of [GR 57].

7.4.12 Impulse Noise

The E-DVA impulse noise MUST meet:

- ≤ 15 impulses in 15 minutes with no holding tone applied at a threshold of 47 dBmC0.
- ≤ 15 impulses in 15 minutes with a -13 dBm0 tone at 1004 Hz at a threshold of 65 dBmC0.

These SHOULD be met for both the on-hook and off-hook transmission path. For a line under test, other lines on the E-DVA SHOULD be active (off-hook, dialing, ringing, etc.).

Reference: section 5.3.16 of [GR 909] and section 6.1.15 of [GR 57].

7.4.13 Intermodulation Distortion

The E-DVA intermodulation distortion MUST meet:

- $R_2 > 43$ dB using a -13 dBm0 input signal
- $R_3 > 44$ dB using a -13 dBm0 input signal

R_2 and R_3 are the 2nd and 3rd order intermodulation products measured using the IEEE 743-1984 4-tone method.

Reference: section 6.1.16 of [GR 57].

7.4.14 Single Frequency Distortion

The E-DVA single frequency distortion MUST meet:

- Using a 0 dBm0 input signal between 0-12 kHz, the output between 0-12 kHz < -28 dBm0
- Using a 0 dBm0 input signal between 1004-1020 Hz, the output between 0-4 kHz < -40 dBm0

Reference: section 6.1.17 of [GR 57].

7.4.15 Generated Tones

The E-DVA generated tones MUST meet:

- < -50 dBm0 between 0-16 kHz

Reference: section 5.3.20 of [GR 909].

7.4.16 Peak-to-Average Ratio

The E-DVA peak-to-average ratio of transmission paths MUST meet:

- $P/AR > 90$ with a -13 dBm0 input level. On-hook and off-hook transmission paths

Reference: section 6.1.19 of [GR 57].

7.4.17 Channel Crosstalk

With a 0-dBm0 signal between 200-3400 Hz applied to a line, other lines on the E-DVA MUST meet < -65 dBm0 C message weighted output between 200-3400 Hz.

Reference: section 5.3.22 of [GR 909] and section 6.1.20 of [GR 57].

7.5 Out of Service Requirements

The PacketCable specification [RSTF] section, In-Service and out-of-service states, defines the conditions where the E-DVA determines a network availability state and uses one of several analog line supervisory tones (dial tone, re-order tone, etc.) to indicate to the end user or device the current network state when a connection is attempted (E-DVA off hook state).

In addition to supervisory tones, some end user devices (security systems) also determine network connection likelihood by detecting the analog telephony DCbias at the E-DVA telephony termination point. This technique continuously monitors the DCbias and the loss of DCbias is interpreted by the security system as an alarm state. This type of alarm service, therefore, also requires mechanisms to manage the analog telephony DCbias signal both in the E-DVA on hook and off hook state to indicate the current network availability state.

The goal must be to provide E-DVA telephony termination point conditions (DCbias and supervisory tone signals) consistent with historical PSTN services while also providing a method where planned or scheduled Network or E-DVA operations (network maintenance, software downloads, reboots) do not cause unwanted or inappropriate security alarms.

Due to the fact that end user alarms are subject to the E-DVA and network availability states, including short term, planned outages, it is required to allow the service provider to provision various parameters related to network availability state including planned outages, signaling types, timer durations etc. to properly signal the current system state to the end user and the end user devices.

7.5.1 E-DVA On Hook State

In this E-DVA state, the DCbias is the signaling method to indicate the Network/E-DVA in/out-of-service state. The E-DVA MUST support provisioning of the On Hook state DCbias. The Operator is able to provision to enable planned, scheduled service times to not be signaled as an out-of-service state pending a maximum duration element.

DCbiasSig element enables/disables the DCbias management per provisioned values on a per telephony port basis.

The E-DVA MUST perform DCbias per DCbias provisioned elements with a DCbiasSign element value of 0.

A value of 1 indicates that the DCbias is not controlled by the provisioned elements.

DCbiasMax element sets the maximum period of time that a DCbias is to be maintained following an E-DVA reboot requiring a in-service State re-establishment per [RSTF]. The E-DVA MUST maintain DCbias following an E-DVA reboot requiring an in-service State re-establishment per [RSTF] for the time period indicated in the DCbiasMax element.

Upon any reset or reboot, the E-DVA SHOULD NOT remove DCbias from the telephony termination point for longer than the Network Disconnect Interval (typically 1 second +/- 400 milliseconds). The E-DVA MUST NOT remove DCbias for more than 5 seconds, as long as the operational AC or battery power supply to the E-DVA is maintained across such an initialization event. An E-DVA then MUST comply with the DCbiasMax element. Note that not every security system will accept a 5-second DCbias removal time without alarming. Therefore, it is important to minimize any outage time under any condition.

If the Network/E-DVA fails to re-establish the in-service state per [RSTF] during the DCbiasMax duration, the E-DVA MUST remove the DCbias from the telephony port when the DCbiasMax duration expires.

If the Network/E-DVA succeeds to re-establish the in-service state per [RSTF] during the DCbiasMax duration, the E-DVA MUST cancel the DCbiasMax resulting in the DCbias being maintained on the telephony port in support of normal telephony signaling requirements.

DCbiasHold element sets the period of time that a DCbias is maintained following an out-of-service state per [RSTF]. The E-DVA MUST maintain DCbias following an out-of-service state per [RSTF] for the period of time indicated in the DCbiasHold date element.

If the DCbiasHold duration expires, the E-DVA MUST remove DCbias from the telephony port.

If the Network/E-DVA succeeds to re-establish the in-service state per [RSTF] during the DCbiasHold duration, the E-DVA MUST be cancel DCbiasHold resulting in the DCbias being maintained on the telephony port in support of normal telephony signaling requirements.

DCbiasEnable element sets a delay time period prior to reapplying DCbias on the E-DVA telephony port following the re-establishment of the in-service state per [RSTF] and following a DCbias removal. This avoids "race" conditions between the Network/E-DVA transitions from inappropriately signaling to the end user security system. The E-DVA MUST reapply DCbias on the telephony port following the re-establishment of the in-service state per [RSTF] and following a DCbias removal after the delay timer period indicated by the DCbiasEnable element.

Table 6 - Network/E-DVA On Hook In/Out of Service

Data	Type	Persistence	Scope	Stored by	Written by	Read by	Range	Default
DCbiasSig	Boolean	Non-volatile	Per Line	E-DVA	XDS	XDS E-DVA	n/a	false
DCbiasMax	Integer (seconds)	Non-volatile	Per Line	E-DVA	XDS	XDS E-DVA	0 to 2400	1200
DCbiasHold	Integer (seconds)	Non-volatile	Per Line	E-DVA	XDS	XDS E-DVA	0 to 1200	600
DCbiasEnable	Integer (seconds)	Non-volatile	Per Line	E-DVA	XDS	XDS E-DVA	0 to 60	5

Considerations:

1. During call processing states, the E-DVA MUST NOT remove DCbias from the telephony termination point for longer than the Network Disconnect Interval (typically 1 second +/- 400 milliseconds).
2. The echo canceller in the E-DVA MUST be able to pass test 14 in [G 168] when a V-series low-speed (< 9,6 kbit/sec) modem is used which does not send a 2100 Hz disable tone with phase reversals. This is not unique to E-DVA to home security systems but is reflective of compliance to ITU-T V.25 requirements for in band analog modem signaling.

7.5.2 E-DVA Off Hook State

In this E-DVA state, In-Service and out-of-service states MUST be supported as per [RSTF].

Some E-DVA telephony termination ports may be used by security systems which may require the removal of DCbias to signal an alarm state. The enabling of the DCbiasSig element which enables/disables the DCbias management per provisioned values on a per telephony port basis will provide selective management of the DCbias signaling on a per telephony port basis.

All sub-elements of DCbiasSig MUST be supported if DCbiasSig is enabled.

7.5.3 DTMF Signaling

Some Home Alarm systems use proprietary DTMF signaling protocols. These protocols assume DTMF decoders and encoders meet Telcordia or ETSI standards. This places specific requirements on the E-DVA with respect to DTMF relay. DTMF telephone-events **MUST** be fully played out by an egress gateway according to the duration specified in the event subject to an optional minimum play-out duration. The DTMF events **MUST** be provisioned on the E-DVA endpoint per the [CODEC-MEDIA] to reflect Telcordia [GR 506] section 15.4.8, DTMF Signal Duration R15-52. DTMF signals generated by an E-DVA **MUST** have a signal duration of 50 milliseconds.

7.5.4 Expanded Network Service Outages

While services have been offered to provide operators methods to minimize Home Security System alarms during scheduled or known periods of network un-availability, situations may still exist where it is desirable for the operator to further expand the DCbias durations beyond the provisioned values. Under these cases, the Operator may remotely direct the E-DVA to expand the current DCbias duration times for a single event so as to provide short term maintenance flexibility while still maintaining Home Security System requirements.

7.6 Message Waiting Indicator

The E-DVA **MUST** follow the general requirements on the Message Waiting Indicator (MWI) given in [RSTF].

Upon receiving the NOTIFY message from the MWI Application Server, the E-DVA **MUST** present the corresponding MWI to the user's CPE device via a MWI tone, a MWI voice announcement, a MWI FSK signal, or a MWI DTMF signal, according to the provisioned UE MWI Tone Indication, UE MWI Voice Announcement Indication, UE MWI FSK Indication and UE MWI DTMF Indication data parameters in Table 7. The following are additional requirements on MWI:

- The MWI FSK or DTMF signal is presented to the user's CPE device through the analog port on the E-DVA when the CPE device is on-hook. In presenting these signals, the E-DVA **MUST** follow the corresponding requirements in [GR 30] section 2.3.2, [SR-TSV-002476], [GR 1401], [GR 506], [EN 300 659-1] Clause 6.2, and [EN 300 659-3] Clause 5.2.2.
- The MWI tone or voice announcement **MUST** be presented to the user's CPE device through the analog port on the E-DVA when the CPE device goes off-hook.
- If the MWI arrives while the line is busy, the E-DVA **MUST** delay the presentation until the line goes back to the idle state.

The E-DVA can have built-in capabilities to present the MWI signals in a visual or audible format directly to the user. Such local capabilities are vendor-specific and are outside the scope of this specification.

Table 7 - MWI Signal Types

Data	Type	Persistence	Scope	Stored by	Written by	Read by	Mandatory/Optional
UE MWI Tone Indication	Boolean	Non-volatile	Per public user ID	XDS	XDS	UE	Mandatory
UE MWI Voice Announcement Indication	Boolean	Non-volatile	Per public user ID	XDS	XDS	UE	Mandatory
UE MWI FSK Indication	Boolean	Non-volatile	Per public user ID	XDS	XDS	UE	Mandatory
UE MWI DTMF Indication	Boolean	Non-volatile	Per public user ID	XDS	XDS	UE	Mandatory

8 CLIENT REQUIREMENT

8.1 Security

The security considerations for the E-DVA are based on those specified in [PKT 33.203], [PKT 23.228], [PKT 24.229], and [NFT TR]. The requirements specific to the E-DVA are provided below.

8.1.1 Authentication

Upon initialization, the E-DVA performs a bootstrapping procedure with a PAC element to obtain its credentials, which in turn are used to authenticate the E-DVA to the PacketCable core network.

Specifically, as part of initialization and before the SIP registration, the E-DVA MUST carry out the certificate-based mutual authentication procedure with a PAC authentication server [RST PACM], during which a TLS tunnel is established between them. The E-DVA MUST then use HTTP to fetch its provisioned credential materials, including a Private User Identity/Public User Identity pair and the associated User ID/Password pair for each of the provisioned telephony line on the E-DVA.

Then, as part of the SIP registration for each provisioned line, the E-DVA MUST support SIP-Digest-based authentication with the PacketCable core network as detailed in [PKT 33.203] and [PKT 24.229], using the corresponding Private User Identity/Public User Identity pair and the User ID/Password pair obtained from the PAC authentication server during the bootstrapping process. The registration also allows the E-DVA to establish any necessary security associations for the SIP signaling security with the P-CSCF, as specified in [PKT 33.203].

The E-DVA MAY support any other authentication procedure described in [PKT 33.203].

8.1.2 Signaling Security

The E-DVA MUST support TLS for the SIP-signaling security.

The E-DVA MAY support other signaling-security protocols specified in [PKT 33.203].

For both authentication and signaling security the E-DVA MUST use the X.509v3 certificate profile as follows.

E-DVA certificates MUST follow the MTA Device certificate profile specified in [SEC1.5]. Existing PacketCable 1.0 and 1.5 MTA certificates are being reused for PacketCable Release 2.0. E-DVA certificates MUST be issued by MTA Manufacturer Certificate Authorities as specified in [SEC1.5].

In order to perform TLS with the PAC authentication server as defined in [RST PACM], the E-DVA MUST possess the CableLabs Service Provider Root CA certificate. This certificate is installed into each E-DVA at the time of manufacture or with a secure software download as specified in [SEC1.5] and MUST NOT be updated by the provisioning server.

8.2 NAT/Firewall Traversal

Even though there is no NAT/Firewall between the E-DVA and the CMTS, there may be a network-based NAT/Firewall behind the CMTS.

The NAT/Firewall traversal requirements described in [PKT 23.228], [PKT 24.229], and [NFT TR] SHOULD be supported by the E-DVA.

8.3 Codecs

G.711 μ -law, G.711 A-law [G 711], T.38, V.152, and DTMF Relay MUST be supported by the E-DVA per the [CODEC-MEDIA] specification. Both μ -law and A-law MUST be offered at session establishment if G.711 is offered. The packet period of a G.711 payload is configured as shown in the table below. The offering of T.38, V.152, and DTMF Relay at session establishment is determined based on the setting of their respective data element as described below. Table 8 provides a summary of the E-DVA data elements related to CODEC configuration.

Table 8 - E-DVA CODEC Provisioning

Data	Type	Persistence	Scope	Stored by	Written by	Read by	Range	Increments	Default
G711 Packet	Integer (msec)	Non-volatile	Per E-DVA	XDS	XDS	XDS UE	10-30	10	20
T38	Boolean	Non-volatile	Per E-DVA	XDS	XDS	XDS UE	N/A	N/A	ON
V152	Boolean	Non-volatile	Per E-DVA	XDS	XDS	XDS UE	N/A	N/A	ON
DTMF Relay	Boolean	Non-volatile	Per E-DVA	XDS	XDS	XDS UE	N/A	N/A	ON
RTCPXR Publish_report	IP address	Non-volatile	Per E-DVA	XDS	XDS	XDS UE	N/A	N/A	n/a
RTCPXR	Boolean	Non-volatile	Per E-DVA	XDS	XDS	XDS UE	N/A	N/A	ON
RTCP_RATE	Integer (secs)	Non-volatile	Per E-DVA	XDS	XDS	XDS UE	0-60	1	5

A value of ON for T38 enables fax relay on the E-DVA. The E-DVA MUST enable T.38 operation as provisioned via the T.38 data element.

A value of ON for V152 enables modem relay on the E-DVA. The E-DVA MUST enable V.152 operation as provisioned via the V.152 data element.

A value of ON for DTMF Relay enables DTMF Relay on the E-DVA. The E-DVA MUST enable DTMF Relay operation as provisioned via the DTMF Relay data element.

Publish_report defines the network address that receives the call statistics report from the E-DVA. The E-DVA MUST send Publish reports at the end of each call.

RTCPXR determines if extended reports for the sake of voice metrics are included within RTCP packets. A value of ON enables RTCP extended reports. Voice metrics can include network and audio metrics as defined in [CODEC-MEDIA].

RTCP_RATE sets the interval at which RTCP packets are sent from the E-DVA. A value of zero for RTCP_RATE disables RTCP transmission. The E-DVA MUST send RTCP packets at the rate indicated in the RTCP_RATE data element.

If a voice call is switched to T.38 or V.152, the E-DVA MUST use the same packet period as the prior voice stream for transmitting data.

8.4 Time keeping

A PacketCable E-DVA MUST support a provisioned network time synchronization interval. The E-DVA time synchronization interval range MUST be from 0 to 4320 hours (180 days) in increments of 1 hour. A provisioned value of 0 indicates the E-DVA MUST NOT execute network time resynchronization. The default network time synchronization interface is 48 hours. [RFC 4330] is used for time keeping. The E-DVA MUST support the PKT-PACM-2 reference point defined in [RST PACM].

Table 9 - E-DVA Time Synchronization

Data	Type	Persistence	Scope	Stored by	Written by	Read by	Range	Increments	Default
TimeSync	Integer (hours)	Non-volatile	Per E-DVA	UE	XDS	PACM UE	0-4320	1	48

8.5 Loopback Test Capability

The PacketCable network may initiate a test call to the E-DVA to request that the E-DVA then be set into loopback mode such that network can send RTP streams to the E-DVA, and receive the same stream back. This allows the network operator to test the voice path and, potentially, a number of voice/packet performance statistics.

8.5.1 Test Call Request Encoding

The PacketCable network indicates, via a specific encoding scheme in the SIP INVITE, that the request is to initiate a test call and enable RTP loopback.

To indicate an RTP loop back test call, the INVITE received from the network MUST be encoded with:

- A Require header containing the option tag 'answermode' (reference [ID SIP ANSWERMODE]).
- An Answermode header containing the parameters 'auto;require'.
- SDP attribute 'loopback' indicating the specific loopback behavior required (reference [ID MMUSIC LOOPBACK]).
- SDP attribute 'loopback-source' indicating that the network is the source of the media that is to be the subject of the RTP loopback.

8.5.2 E-DVA Requirements on Reception of a Loopback Request

On reception of an INVITE request encoded as defined in this section, the E-DVA MUST:

- Not alert the subscriber.w4
- Provide a 200 OK final response to the INVITE
- Encode the answer SDP provided in the 200 OK according to the rules in reference [ID MMUSIC LOOPBACK])

On reception of RTP packets from the network, once a Loopback mode has been established, the action at the E-DVA is dependent on the contents of the 'loopback' attribute received in the offering SDP from the network.

If the 'loopback' attribute was encoded as 'rtp-pkt-loopback,' then E-DVA MUST NOT decode the received RTP packet and instead sends the received packet back to the network. The destination IP address and port for the looped RTP is that given in the offering SDP in the initial INVITE.

If the 'loopback' attribute was encoded as 'rtp-media-loopback,' then the E-DVA MUST decode and then re-encode the received RTP payload before sending the received packet back to the network if the E-DVA supports media loop back mode. The destination IP address and port for the looped RTP is that given in the offering SDP in the initial INVITE. The E-DVA MUST reject the INVITE with the 'rtp-media-loopback' if the E-DVA does not support the media loopback mode.

The Loopback test session ends upon reception of a BYE from the network on the dialog established by the initial INVITE.

The E-DVA MUST reject an INVITE request encoded as defined in Section 8.5.2 if it has insufficient resources to meet the requirements of the loopback mode. For example, the E-DVA may already be involved in a 3-way call.

The E-DVA SHOULD end the loopback mode with a BYE if a user request for a 3-way call cannot be serviced due to resource limitations.

9 E-DVA MONITORING REQUIREMENTS

The E-DVA is a critical element in the PacketCable architecture. It provides the customer's interface to the service provider's network, and is located outside the service provider's head end. As such, it is critical that the operational status of the E-DVA be monitored in order to provide the quickest information to the service provider. In particular, if the E-DVA fails and is not capable of providing the intended service, the service provider will need to know about this condition quickly (preferably before the customer).

The minimum goal of fault management should be to isolate failures to a field replaceable unit. Preferably, fault management should be able to identify the failed functional subsystem within the unit. This enables the service provider to dispatch service personnel with the appropriate equipment necessary to troubleshoot and resolve the problem in the least amount of time (i.e., minimize Mean Time To Replacement, or MTTR).

This section provides the E-DVA monitoring requirements in support of proper fault management. Specifically, it provides the monitoring requirements for three main functional subsystems of the E-DVA: the DOCSIS eCM, the PacketCable E-DVA, and the battery-backup module.

9.1 eCM Monitoring

The E-DVA functions as the customer premise network interface to the PacketCable network and thus enables service to the customer. In particular, within the eDOCSIS-compliant E-DVA, the eCM provides the critical connection between the E-DVA and the PacketCable network [eDOCSIS]. An eCM failure will affect the availability of the PacketCable service.

The E-DVA MUST support the eCM failure detection mechanisms defined by DOCSIS specifications [DOCSIS RFIv2.0], [DOCSIS OSSIV2.0], and [eDOCSIS].

For the report of the eCM failures, the E-DVA MUST support the event and alarm reporting mechanisms as defined in [RST PACM].

9.2 E-DVA Monitoring

At the minimum, the E-DVA monitoring MUST utilize the eCM failure detection mechanisms defined by DOCSIS specifications [DOCSIS RFIv2.0], [DOCSIS OSSIV2.0], and [eDOCSIS].

Additional vendor-specific E-DVA monitoring mechanisms MAY be developed. Such mechanisms can include internal on-line diagnostics utilized to detect vendor specific events.

For the report of the E-DVA failures, the E-DVA MUST support the event and alarm reporting mechanisms as defined in [RST PACM].

9.3 Battery-Backup Monitoring

To maintain operation during the utility AC power outage, the E-DVA MAY provide local power with uninterruptible power supply (UPS) battery backup. If the UPS is provided, the E-DVA MUST support the AC Fail, AC Restore, Replace Battery, Battery Good, Battery Missing, Battery Good, Battery Low, and Battery Not Low alarm state telemetry signals for the monitoring of the battery-backup module. For the report of these telemetry signals, the E-DVA MUST support the event and alarm reporting mechanisms as defined in [RST PACM].

9.3.1 Telemetry Signal 1 – AC Fail

The active alarm state of this E-DVA signal MUST indicate an "AC Fail" condition, which means that the UPS has detected a failure of the utility AC power and is operating off its battery.

The inactive alarm state of this E-DVA signal MUST indicate an "AC Restored" condition, which means that the UPS has detected the presence of utility AC power and is no longer operating off its battery.

9.3.2 Telemetry Signal 2 – Replace Battery

The active alarm state of this E-DVA signal MUST indicate a "Replace Battery" condition, which means that the UPS, via internal test mechanisms outside the scope of this specification, has determined that the battery can no longer maintain a charge sufficient enough to provide adequate battery backup and thus is failing and should be replaced with a new battery.

The inactive alarm state of this E-DVA signal MUST indicate a "Battery Good" condition.

9.3.3 Telemetry Signal 3 – Battery Missing

The active alarm state of this E-DVA signal MUST indicate a "Battery Missing" condition, which means that the UPS has detected that a battery is not present and a battery should be installed in the UPS.

The inactive alarm state of this E-DVA signal MUST indicate a "Battery Present" condition.

9.3.4 Telemetry Signal 4 – Battery Low

The active alarm state of this E-DVA signal MUST indicate a "Battery Low" condition, which means that the battery has sufficiently discharged to the point where a power source can only be maintained for a short while longer.

The inactive alarm state of this E-DVA signal MUST indicate a "Battery Not Low" condition, which means that the battery has charged above the "battery low" threshold.

Appendix I Acknowledgements

PacketCable wishes to recognize the following individuals for their significant involvement and contributions to this specification:

Steve Hughey (Arris)

Gordon Li (Broadcom)

Brent Agnew (Broadsoft)

Steve Dotson, Ike Elliott, Kevin Johns, Sandeep Sharma (CableLabs)

Geoff Devine (CedarPoint)

Moh Torabi (Lucent)

Phil Freyman and Bob Stein (Motorola)

John Gilmore, Kevin Boyle (Nortel)

Mark Trayer (Samsung)

Tom Miller (Siemens)

John Bartusek, and Satish Kumar (Texas Instruments)

Bernard McKibben (CableLabs)